

HAMSTER HABITAT

Assembly guide

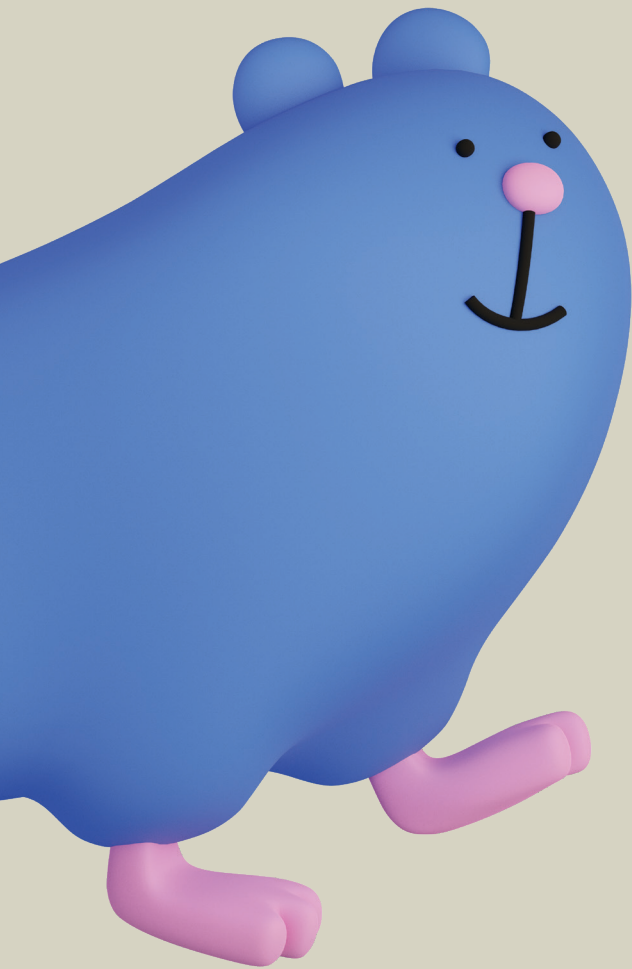

Omlet

LET'S DO THIS

Some people love to build. Others, maybe not so much. We've made the process as intuitive and straightforward as possible, and as you progress, you should find that it all clicks together. The result will make it well worthwhile.

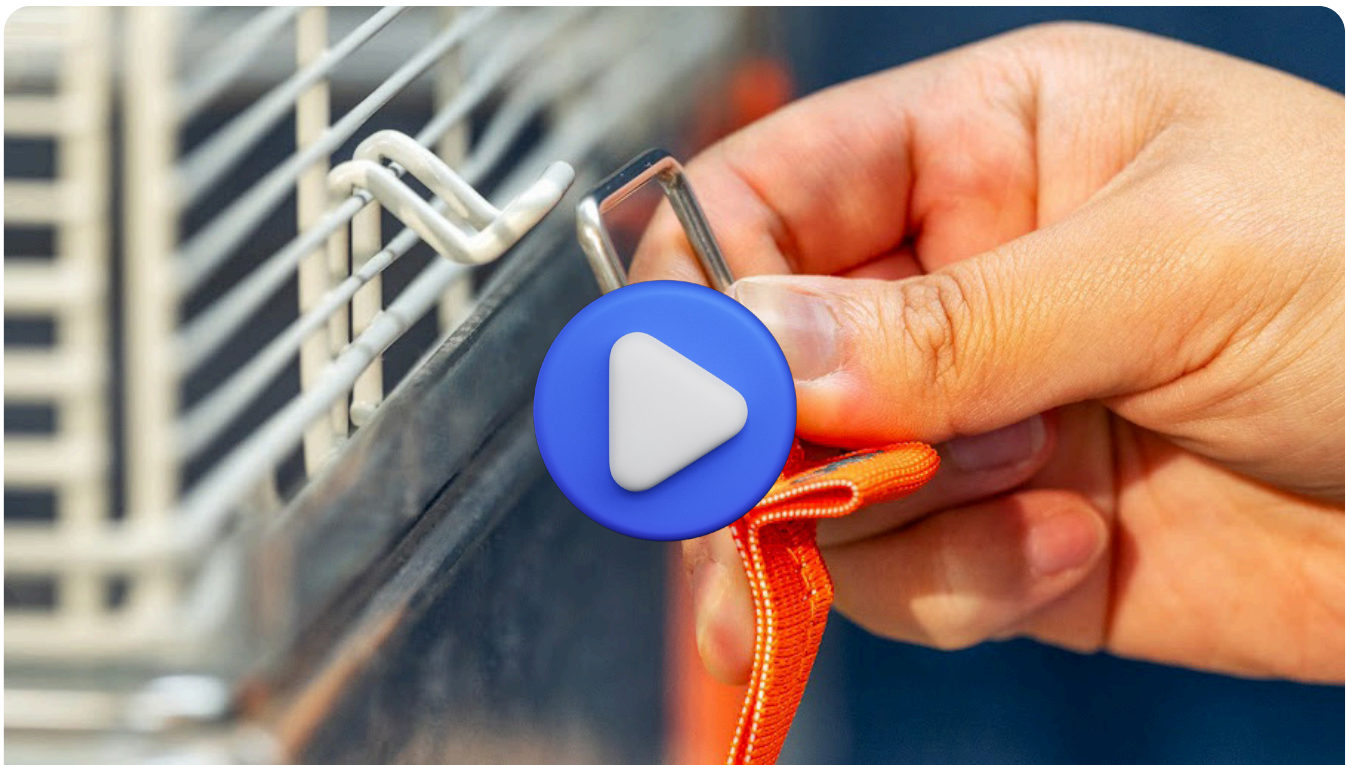

Watch our step by step video to get it right first go.



www.omlet.us/how_to_build

DE Sehen Sie sich jetzt das 'Wie baut man?' Video an

FR Regardez maintenant le tutoriel d'assemblage

NL Bekijk nu de instructievideo

SE Titta på instruktionsvideon nu

What you have received

DE Das haben Sie erhalten • FR Ce qui est fourni • NL Wat u heeft ontvangen • IT Cosa avete ricevuto
SE Vad du har fått • DK Hvad du har modtaget

099.0035 Boxed Hamster Habitat

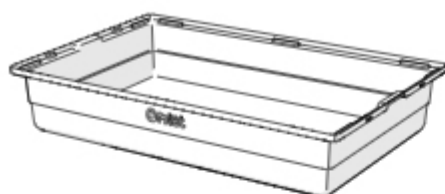

X1
Tray
099.1000

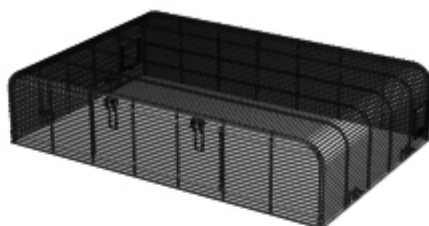

X1
Mesh
099.0001



X4
Strap
099.0060



X2
Bedding Spill-Guard Brace
099.1089

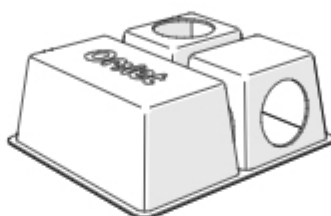

X2
Chamber Hide
099.1069



X1
Water Bottle
810.0303



X1
Food Bowl - Plastic 810.0229

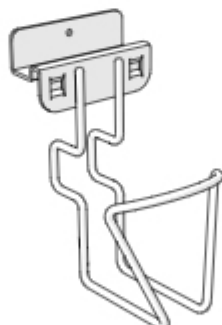

X1
Bottle Holder
099.1086



X1
Wheel
099.0023

099.0063 Boxed Bedding Spill-Guard



X2
Bedding Spill-Guard - Long
099.1091



X2
Bedding Spill-Guard - Short
099.1090

099.0067 Boxed Bedding Spill-Guard Pins Pack



X4
Bedding Spill-Guard Corner Pin
099.1093

Exploded Assembly

DE Montage – Explosionsansicht · FR Assemblage éclaté · NL Exploded view tekening · IT Assemblaggio esplosivo
SE Montering översikt · DK Monteringsoversigt

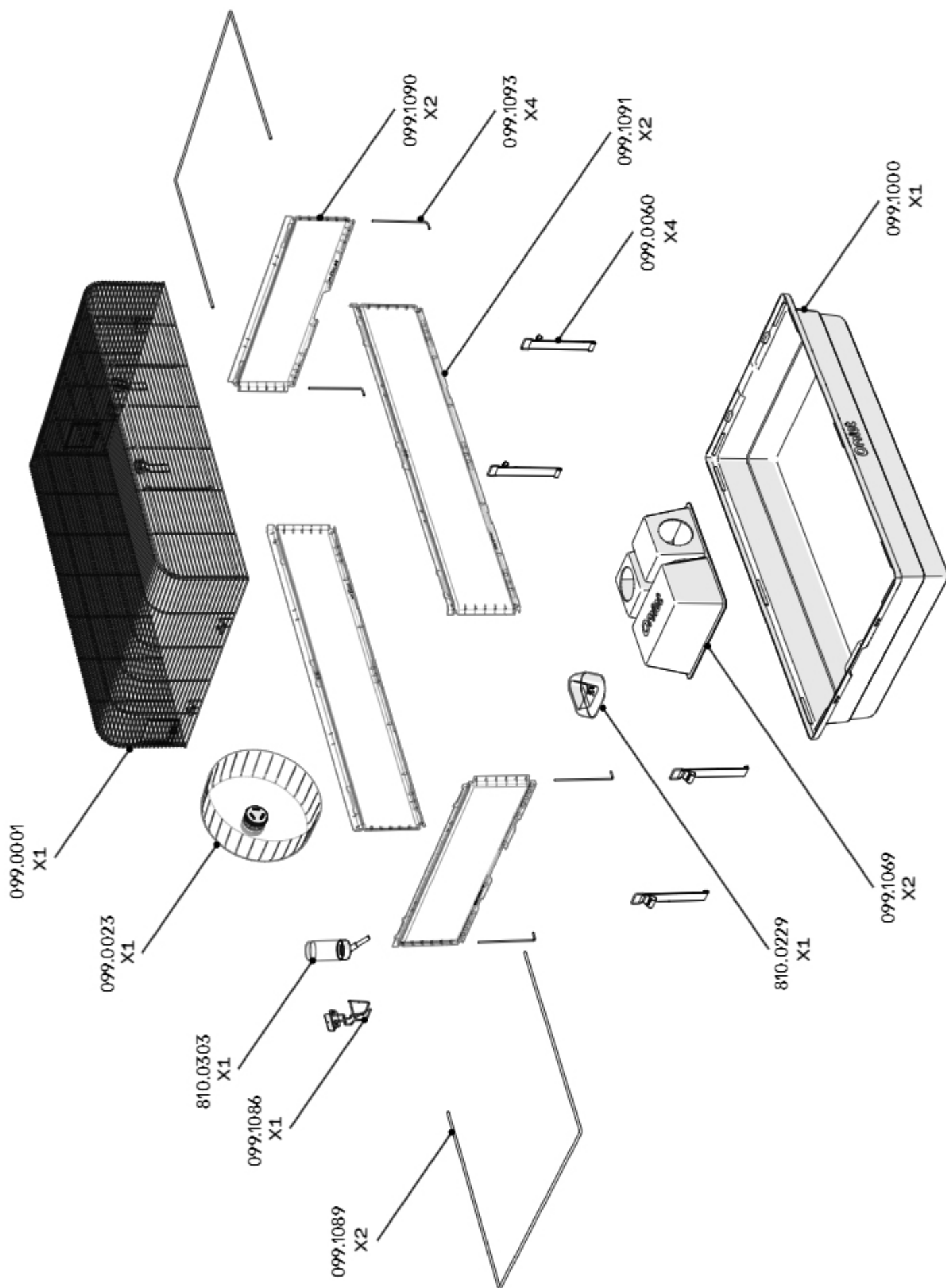

Assemble product on a flat, soft surface like a carpet to prevent scratches



- **DE** Bauen Sie das Produkt auf einer flachen, weichen Oberfläche wie einem Teppich zusammen, um Kratzer zu vermeiden
- **FR** Assemblez le produit sur une surface plane et molle, comme un tapis, afin d'éviter les rayures
- **NL** Monteer het product op een vlakke, zachte ondergrond zoals een tapijt om krassen te voorkomen
- **IT** Assemblare il prodotto su una superficie piana e soffice, come un tappeto, per evitare graffi
- **SE** Montera produkten på en plan, mjuk yta som en matta för att förhindra repor
- **DK** Saml produktet på en flad, blød overflade som et tæppe for at forhindre ridser

1

Pay attention to where your logos are on the panels



- **DE** Achten Sie darauf, wo sich die Logos auf den Paneelen befinden
- **FR** Faites attention à l'emplacement des logos sur les panneaux
- **NL** Let op waar de logo's op de panelen staan
- **IT** Prestare attenzione alla posizione dei loghi sui pannelli
- **SE** Var uppmärksam på var dina logotyper finns på panelerna
- **DK** Vær opmærksom på, hvor dine logoer er på panelerne

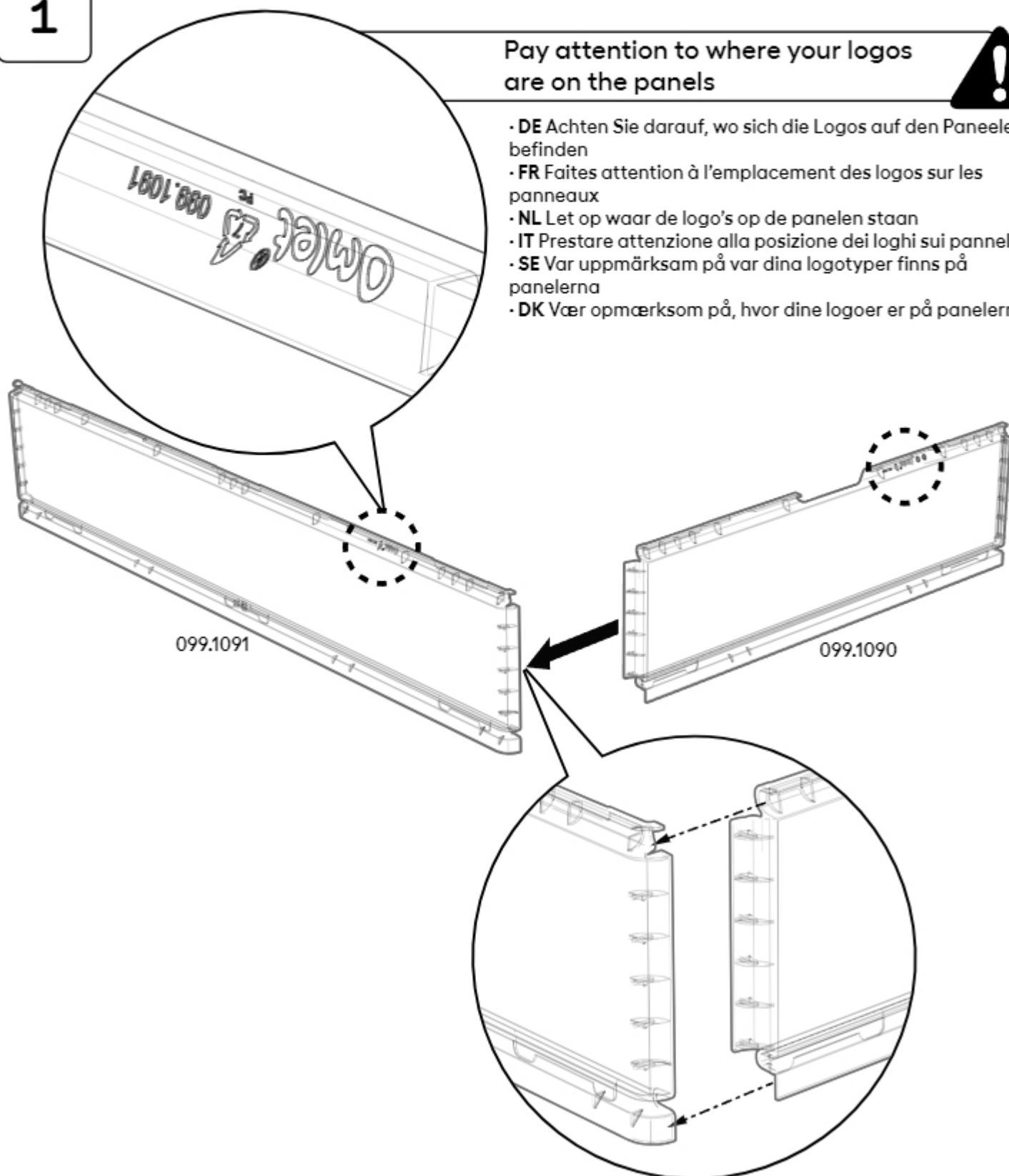

2

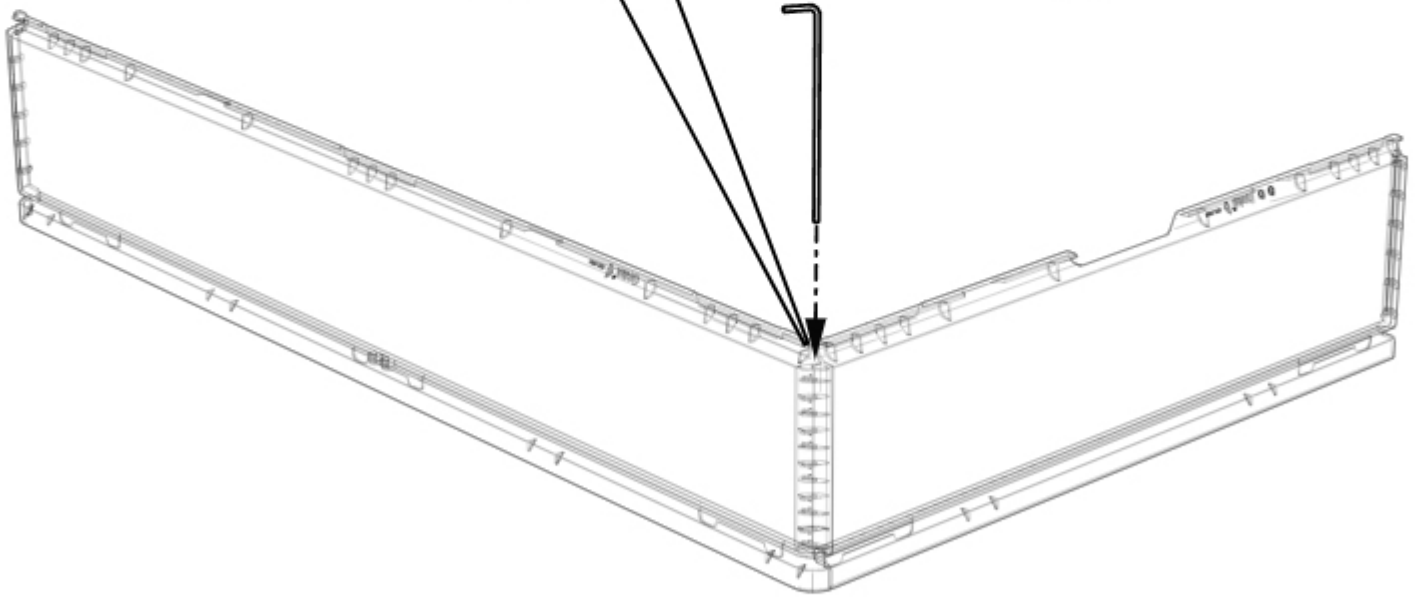
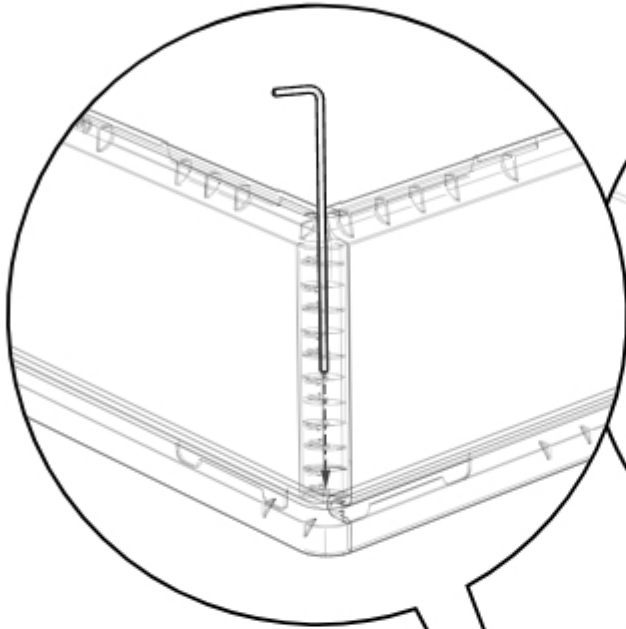

3

Pay attention to where your logos are on the panels



- DE Achten Sie darauf, wo sich die Logos auf den Paneelen befinden
- FR Faites attention à l'emplacement des logos sur les panneaux
- NL Let op waar de logo's op de panelen staan
- IT Prestare attenzione alla posizione dei loghi sui pannelli
- SE Var uppmärksam på var dina logotyper finns på panelerna
- DK Vær opmærksom på, hvor dine logoer er på panelerne

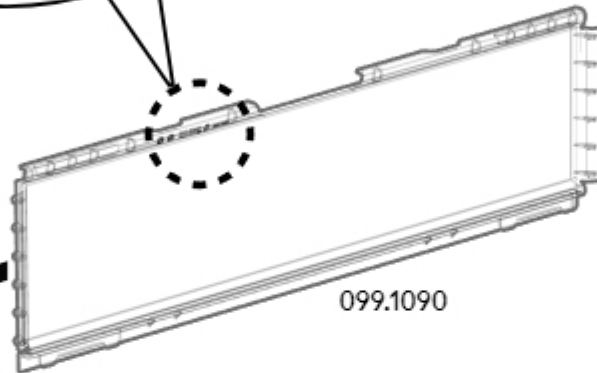
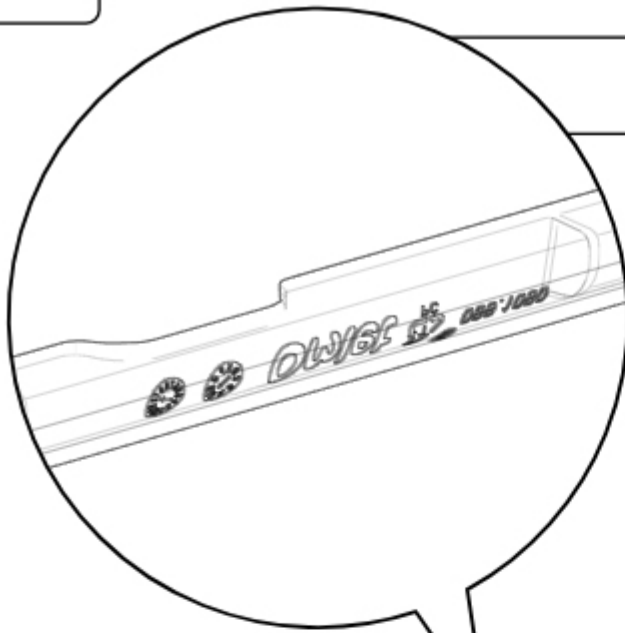

099.1090

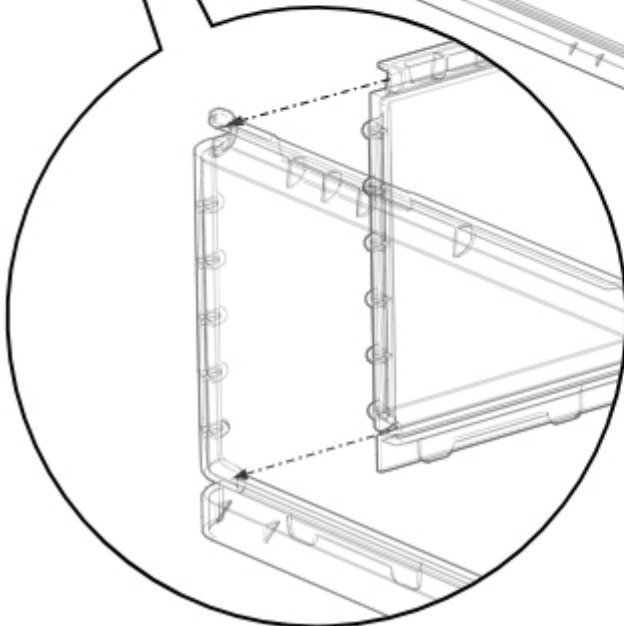
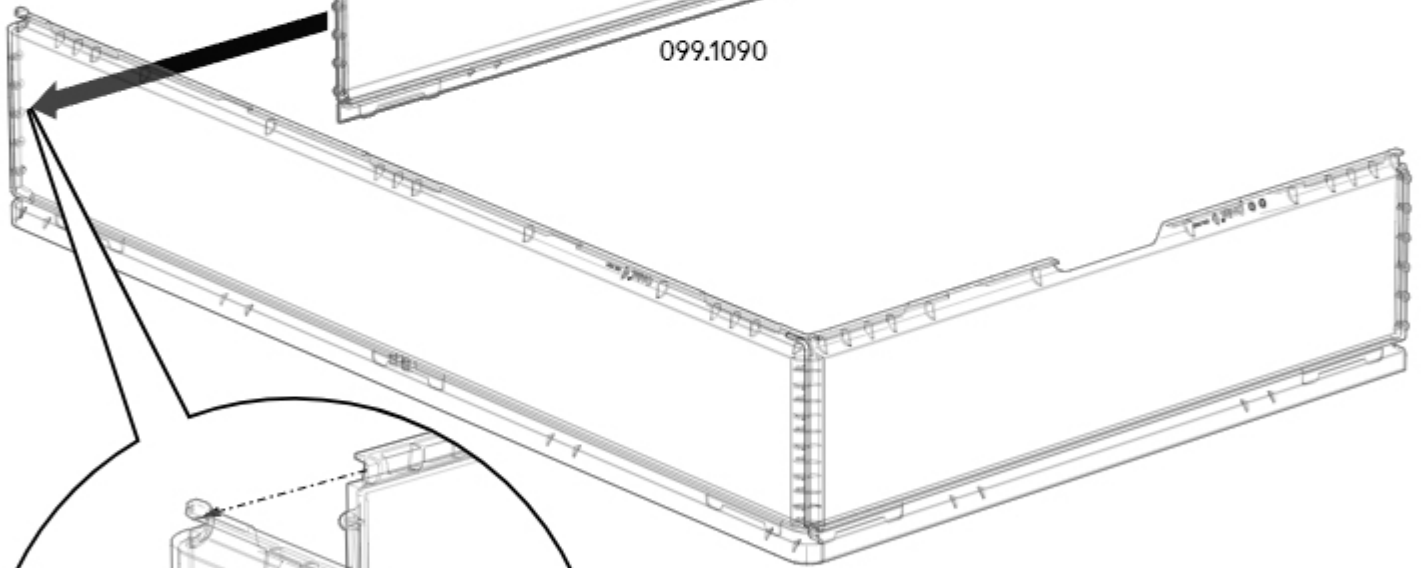

4

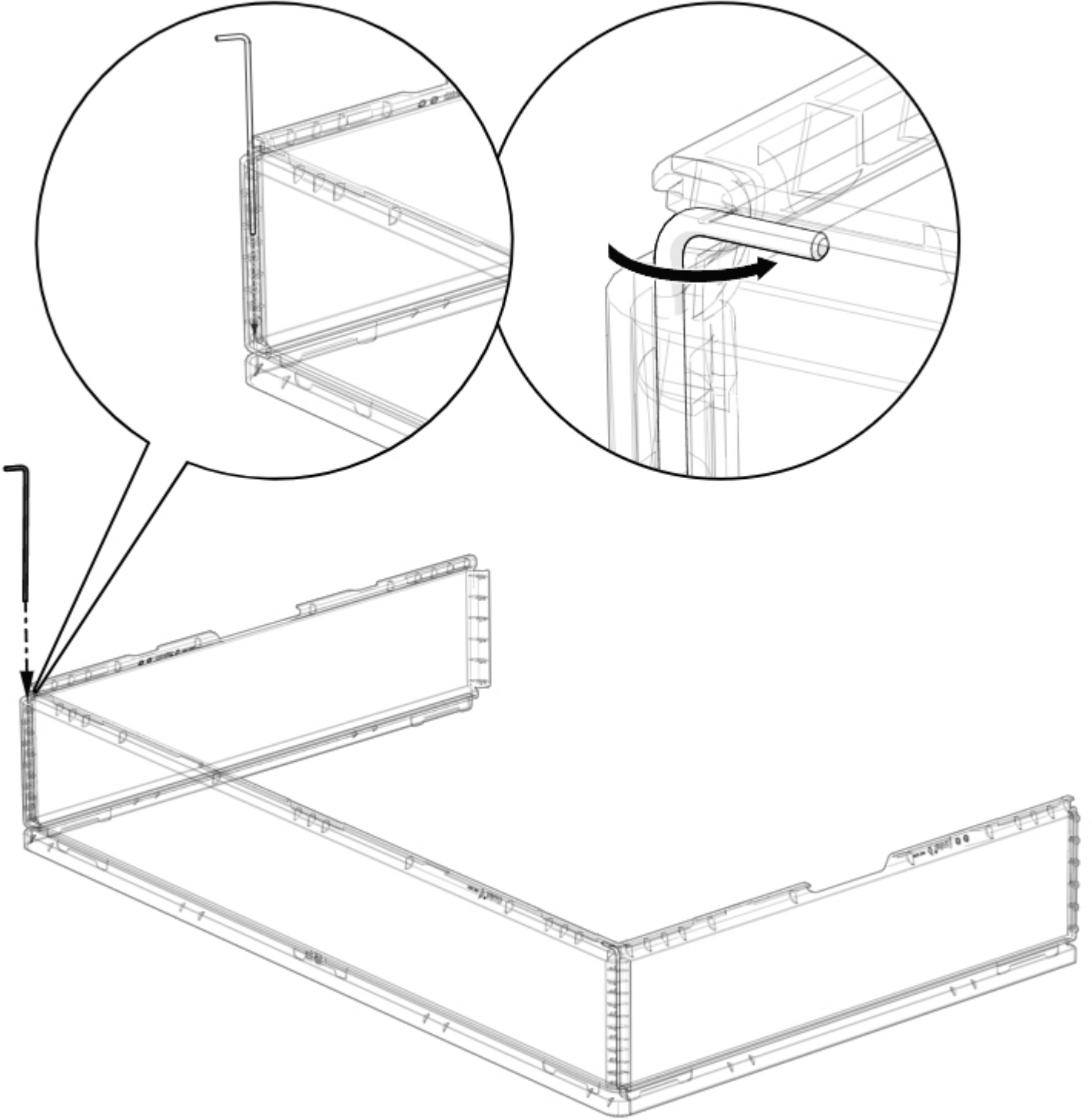

5

Pay attention to where your logos are on the panels 

- DE Achten Sie darauf, wo sich die Logos auf den Paneelen befinden
- FR Faites attention à l'emplacement des logos sur les panneaux
- NL Let op waar de logo's op de panelen staan
- IT Prestare attenzione alla posizione dei loghi sui pannelli
- SE Var uppmärksam på var dina logotyper finns på panelerna
- DK Vær opmærksom på, hvor dine logoer er på panelerne

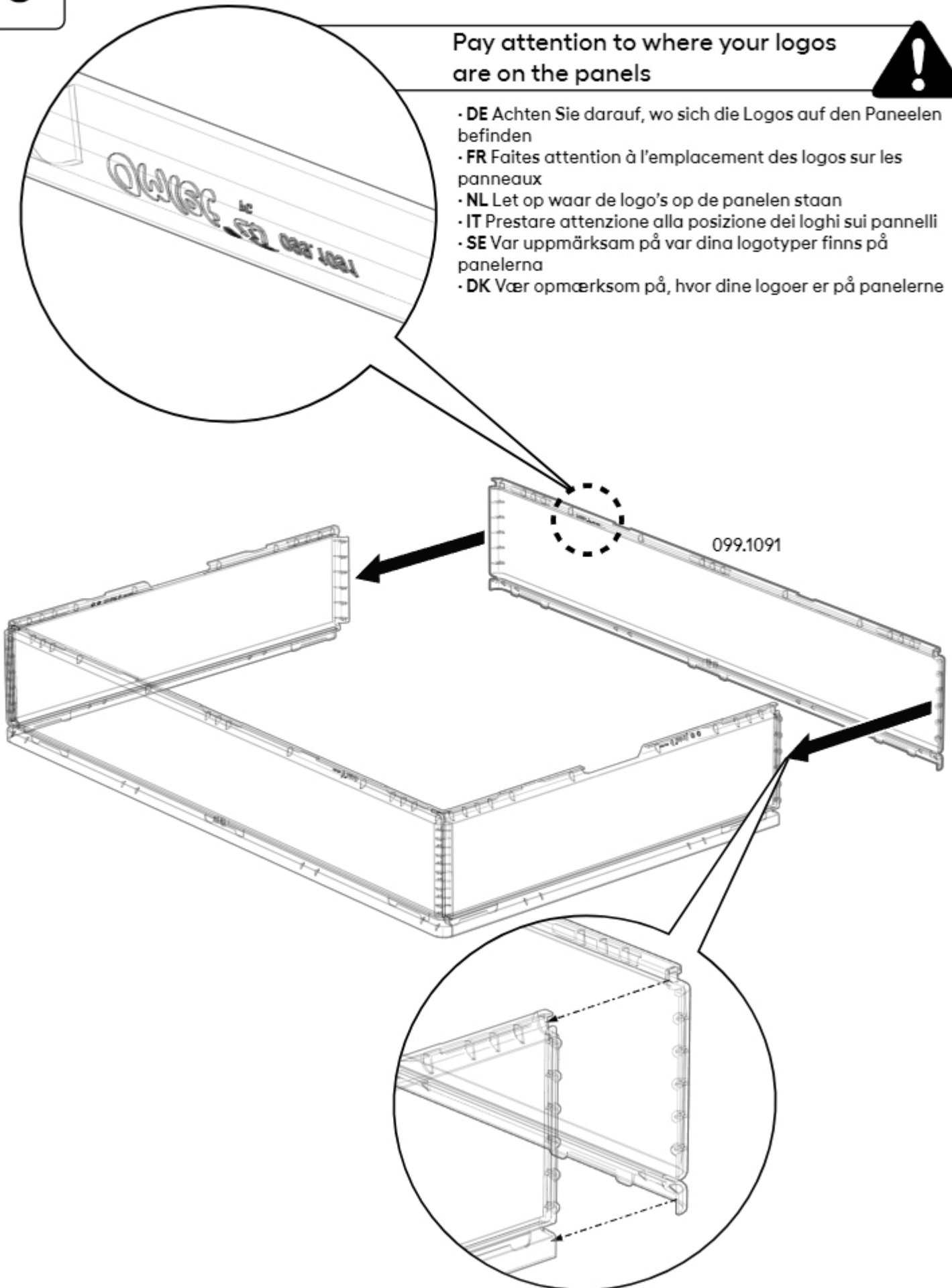

6

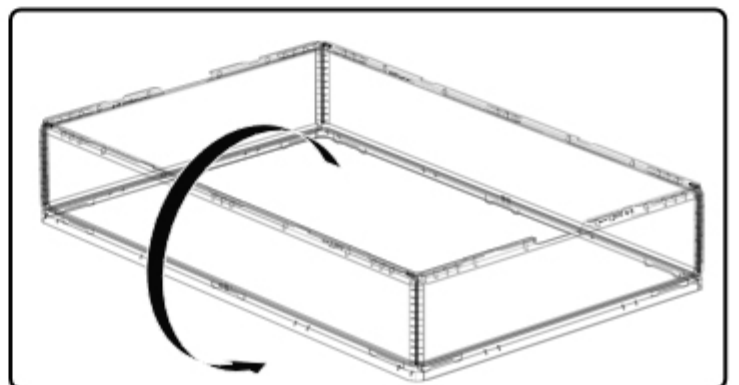
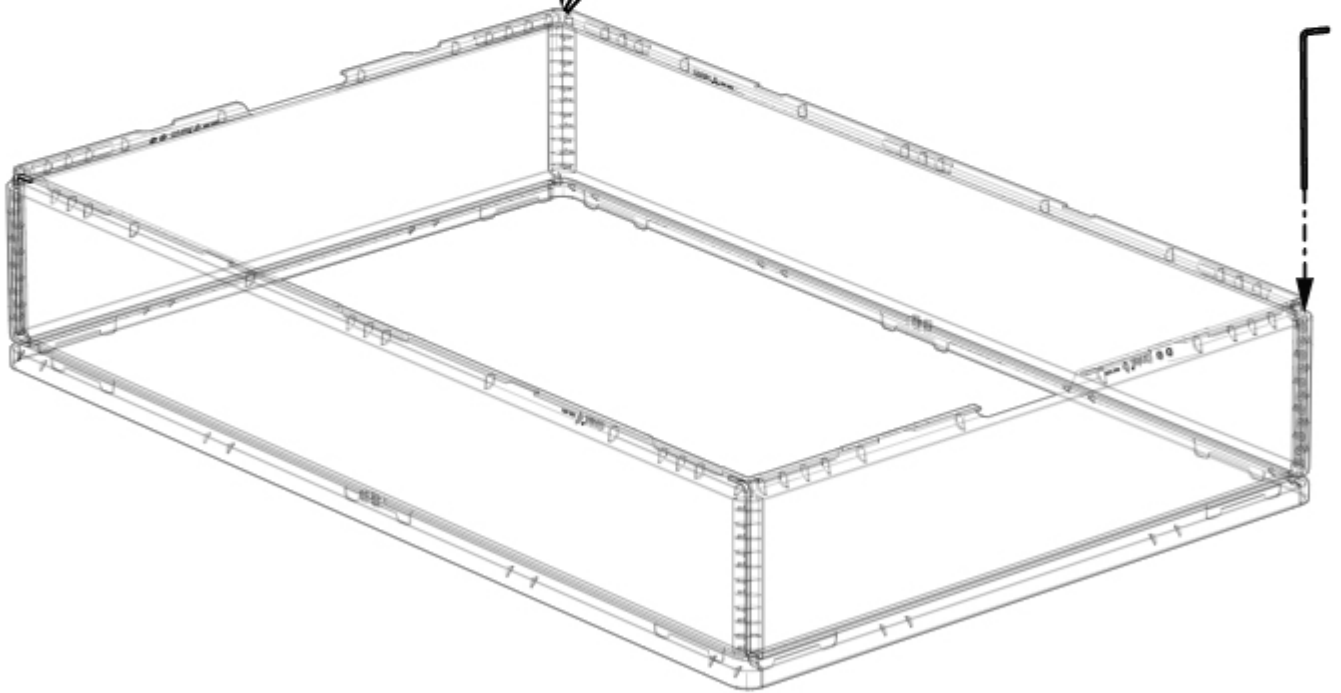
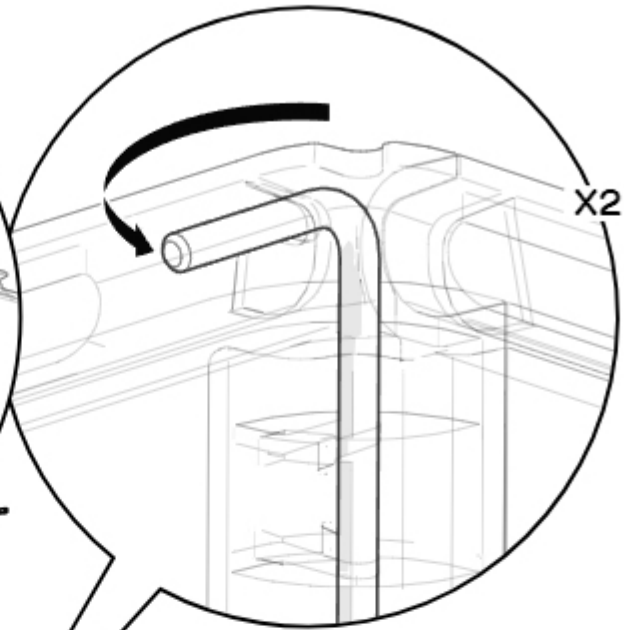
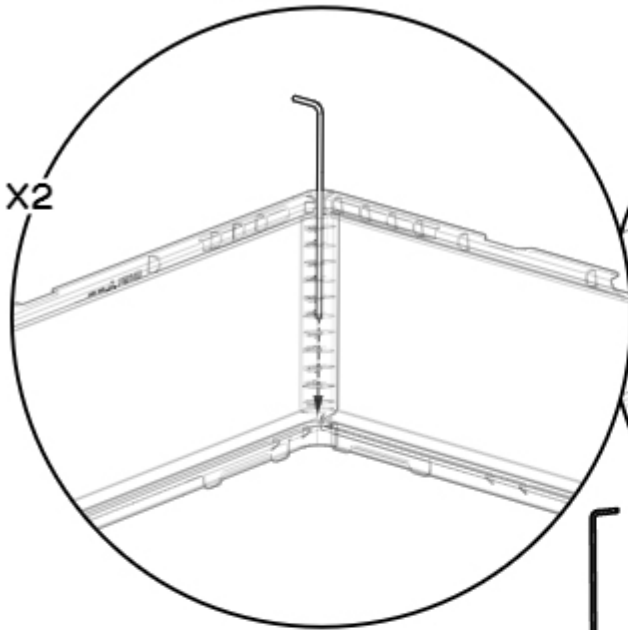

7

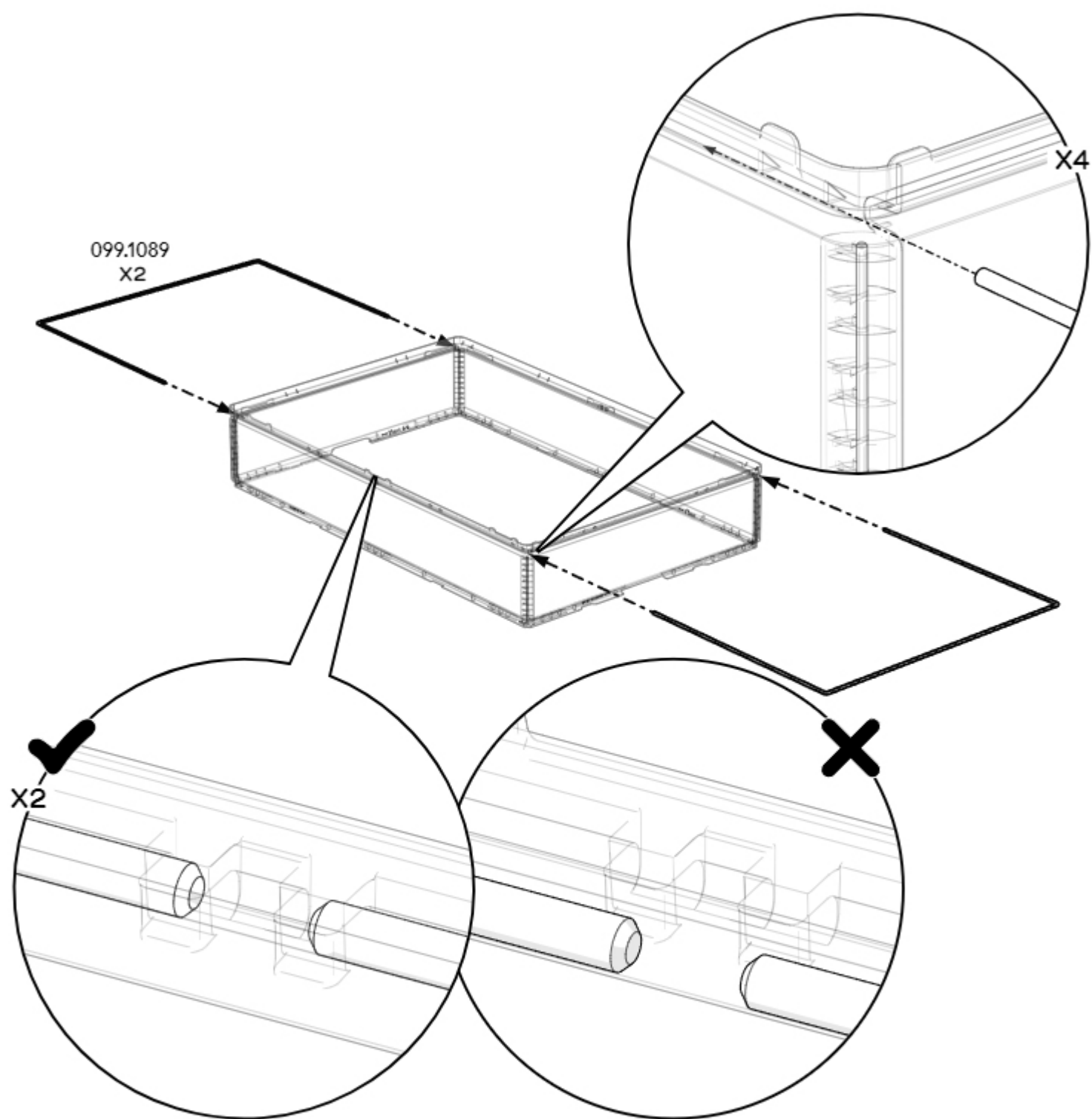

You can use the metal end of **Strap (099.0060)**, which you will use in the next step, to push on the brace corners and click them into place



- **DE** Mit dem Metallende des **Strap (099.0060)**, das Sie im nächsten Schritt verwenden, können Sie auf die Ecken der Strebe drücken und sie einrasten lassen
- **FR** Vous pouvez utiliser l'extrémité métallique de **Strap (099.0060)**, que vous utiliserez à l'étape suivante, pour pousser sur les coins du renfort et les mettre en place
- **NL** U kunt het metalen uiteinde van **Strap (099.0060)**, dat u in de volgende stap gaat gebruiken, gebruiken om de hoekbeugels op te duwen en op hun plaats te klikken
- **IT** È possibile utilizzare l'estremità metallica della **Strap (099.0060)**, che utilizzerai nel passaggio successivo, per spingere gli angoli del tutore e farli scattare in posizione
- **SE** Du kan använda metalländan på **Strap (099.0060)**, som du kommer att använda i nästa steg, för att trycka in hörnen på stag och knäppa dem på plats
- **DK** Brug kan bruge metalenden af **Strap (099.0060)**, som du vil bruge i næste trin, til at skubbe på bøjlernes hjørner og klikke dem på plads

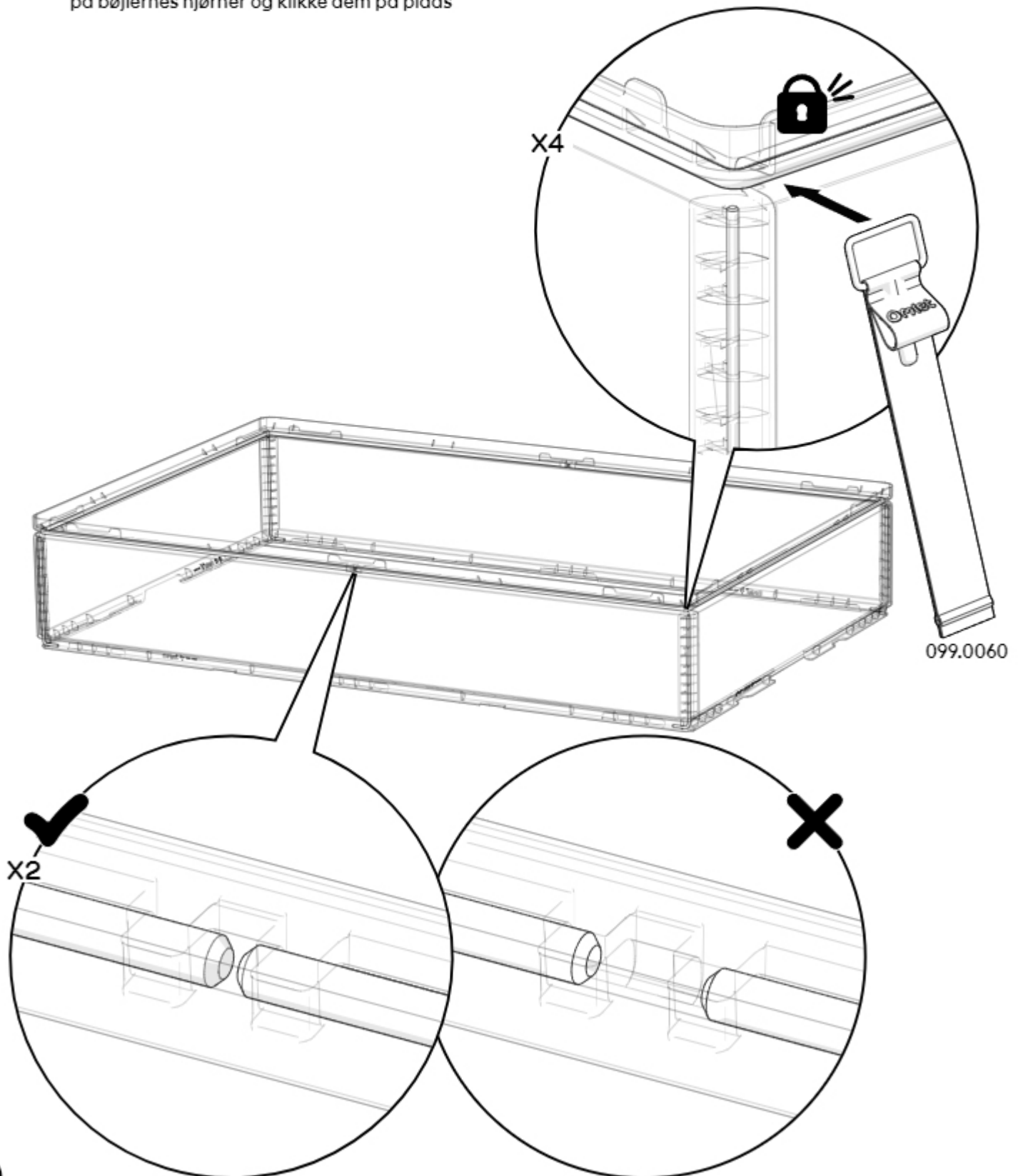

9

099.0060
X4

099.1000

Ormet

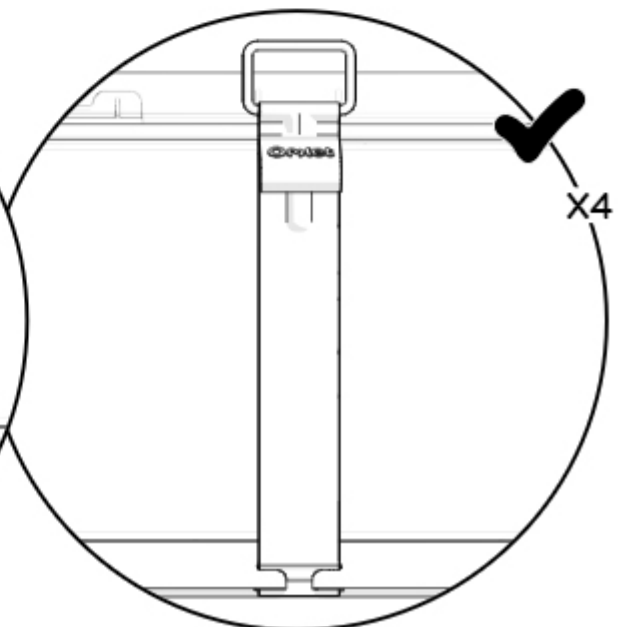
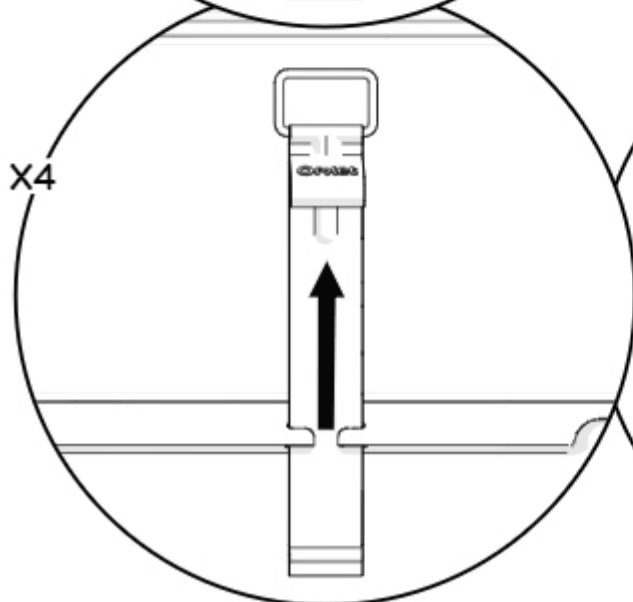
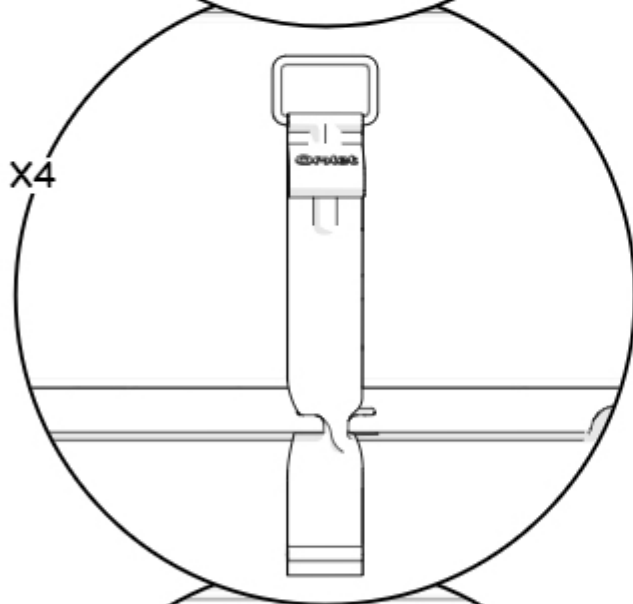
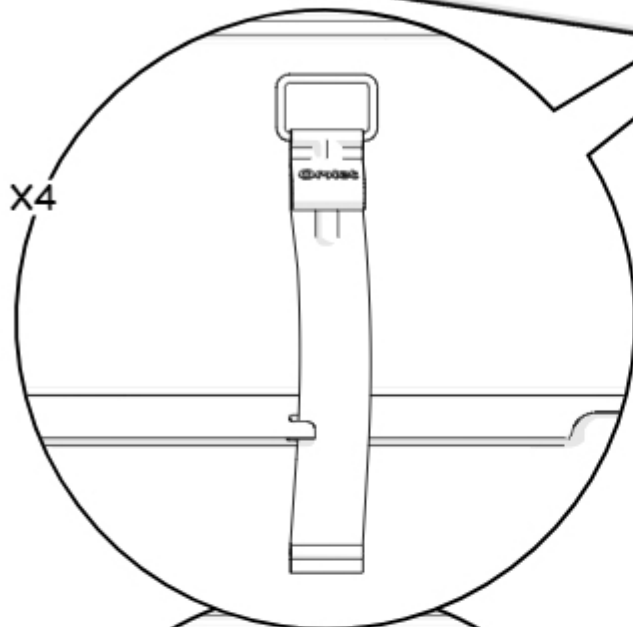

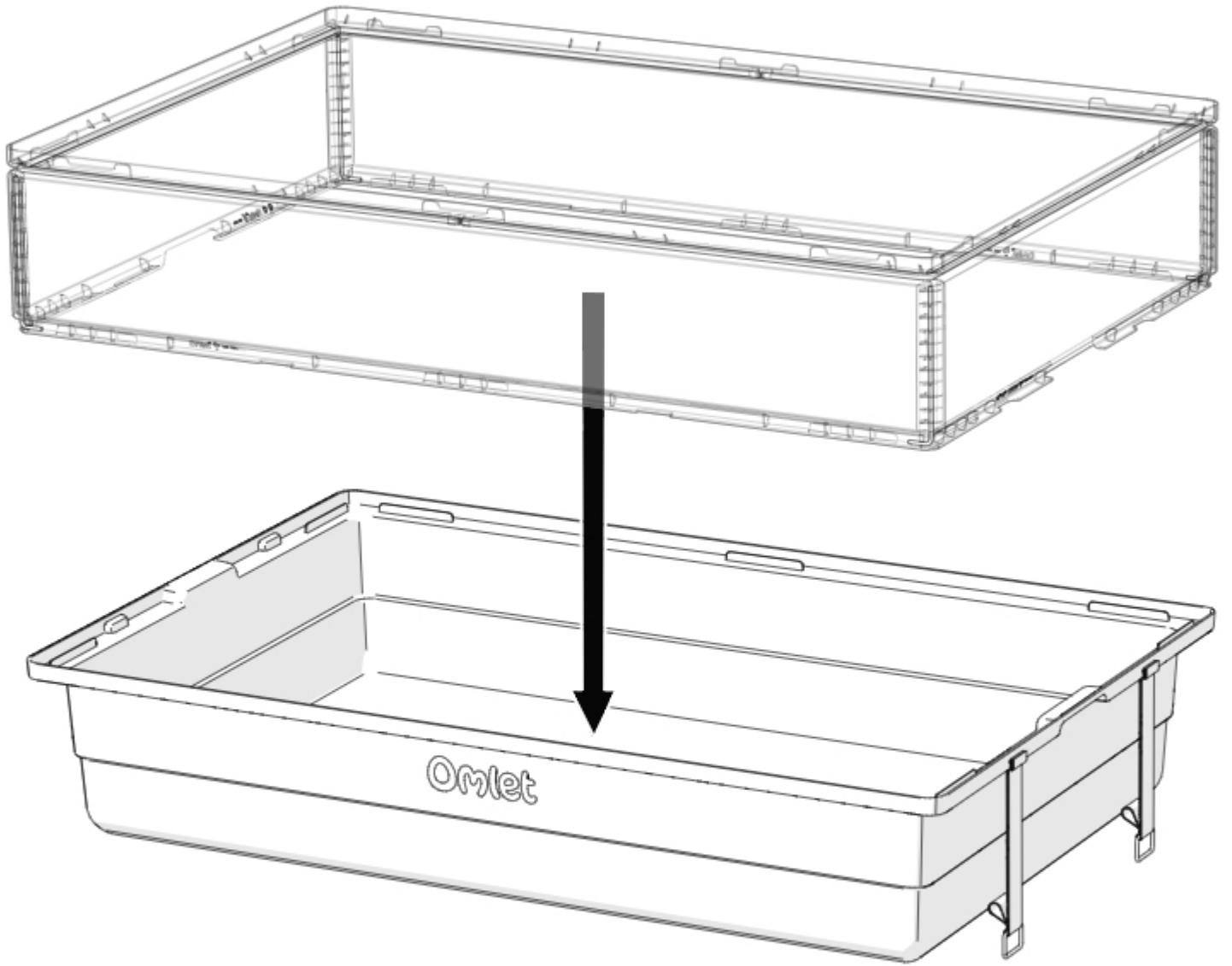

11**Fill half of the Tray (099.1000) with bedding**

DE Füllen Sie die Schale (099.1000) bis zur Hälfte mit Einstreu

FR Remplissez la moitié du bac (099.1000) avec de la litière

NL Vul de helft van de lade (099.1000) met bodemmateriaal

IT Riempire metà del vassoio (099.1000) con la lettiera

SE Fyll halva brickan (099.1000) med strö

DK Fyld halvdelen af bakken (099.1000) med bundmateriale

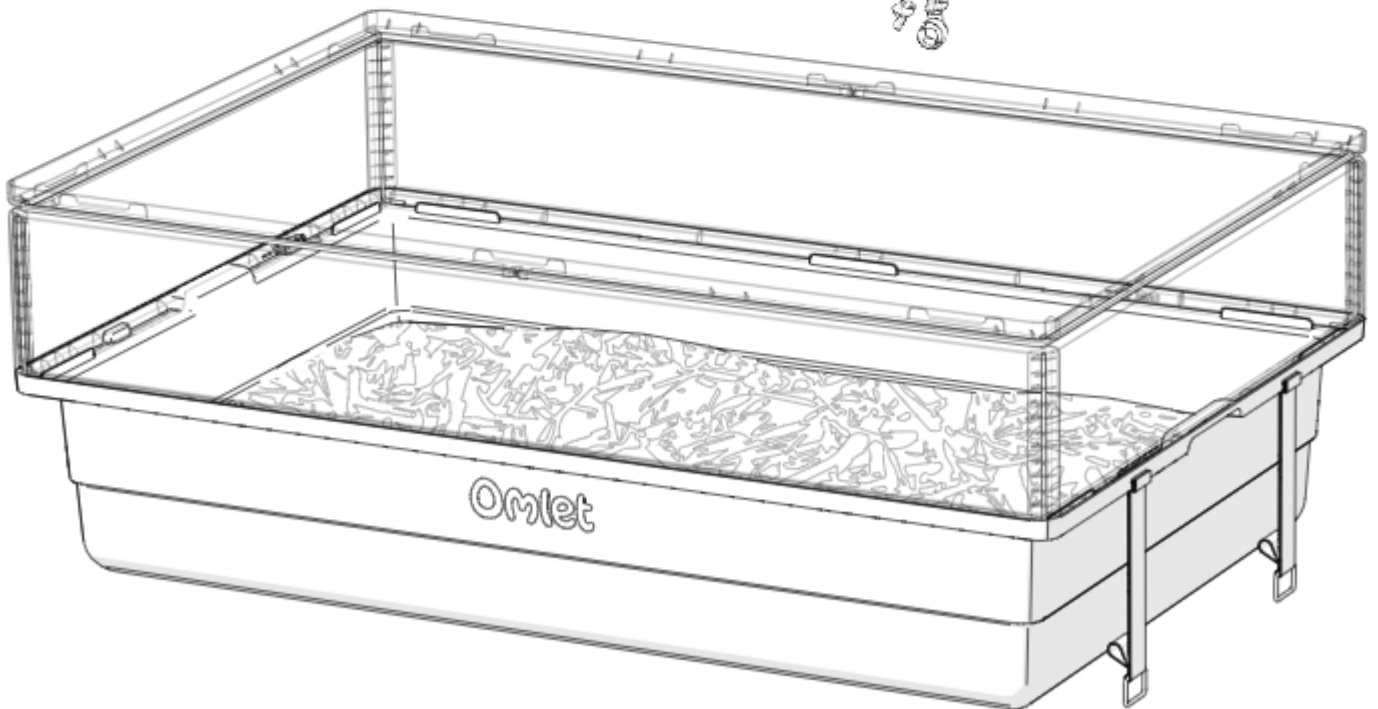
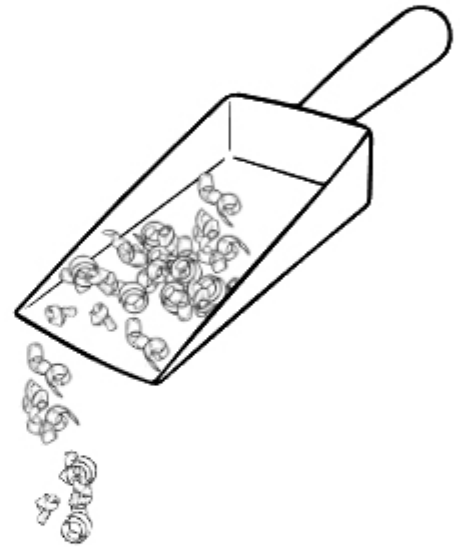
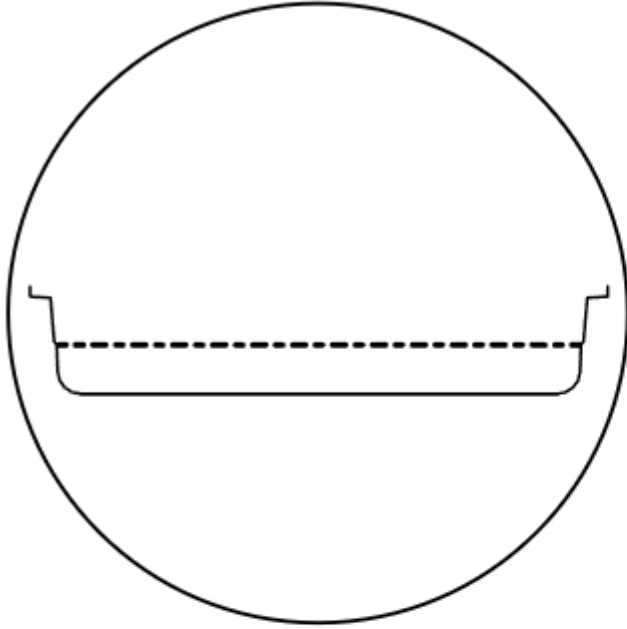

099.1069

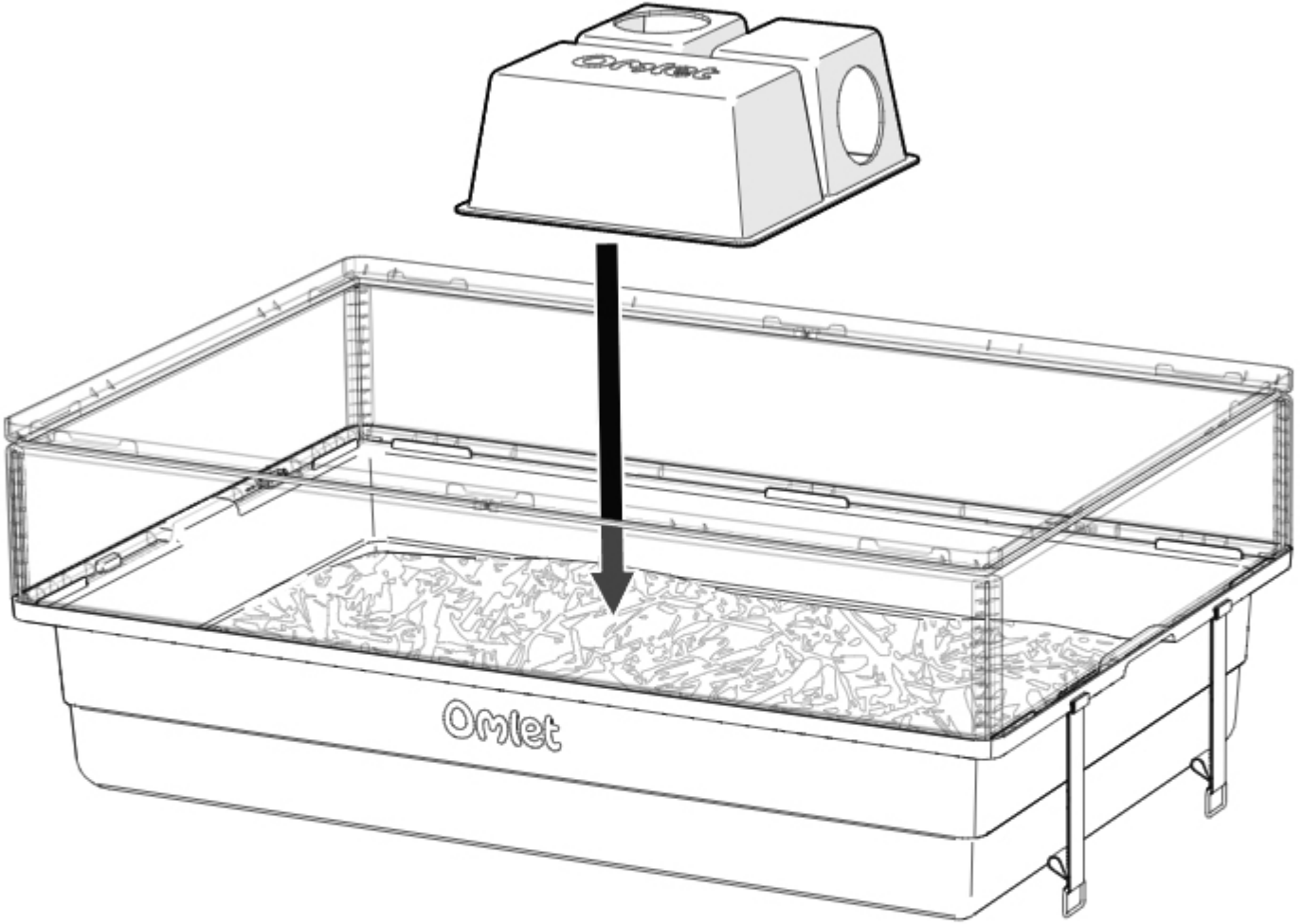

13**Fill the rest of the Tray (099.1000) with bedding**

- DE** Füllen Sie den Rest der Schale (099.1000) mit Einstreu
FR Remplissez le reste du bac (099.1000) avec de la litière
NL Vul de rest van de lade (099.1000) met bodemmateriaal
IT Riempire il resto del vassoio (099.1000) con la lettiera
SE Fyll resten av brickan (099.1000) med strö
DK Fyld resten af bakken (099.1000) med bundmateriale

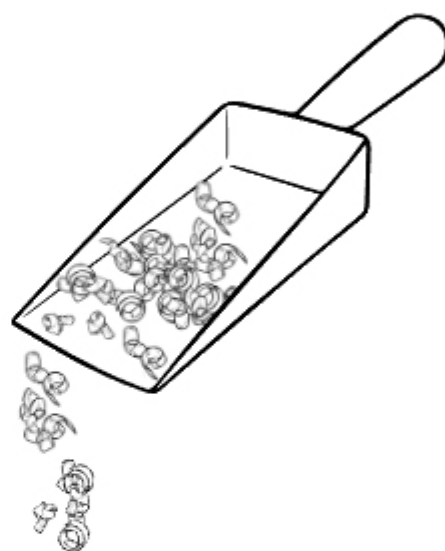
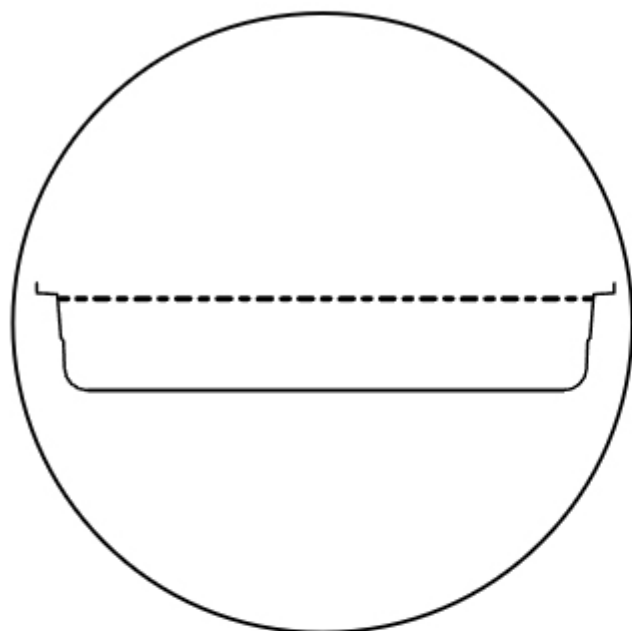

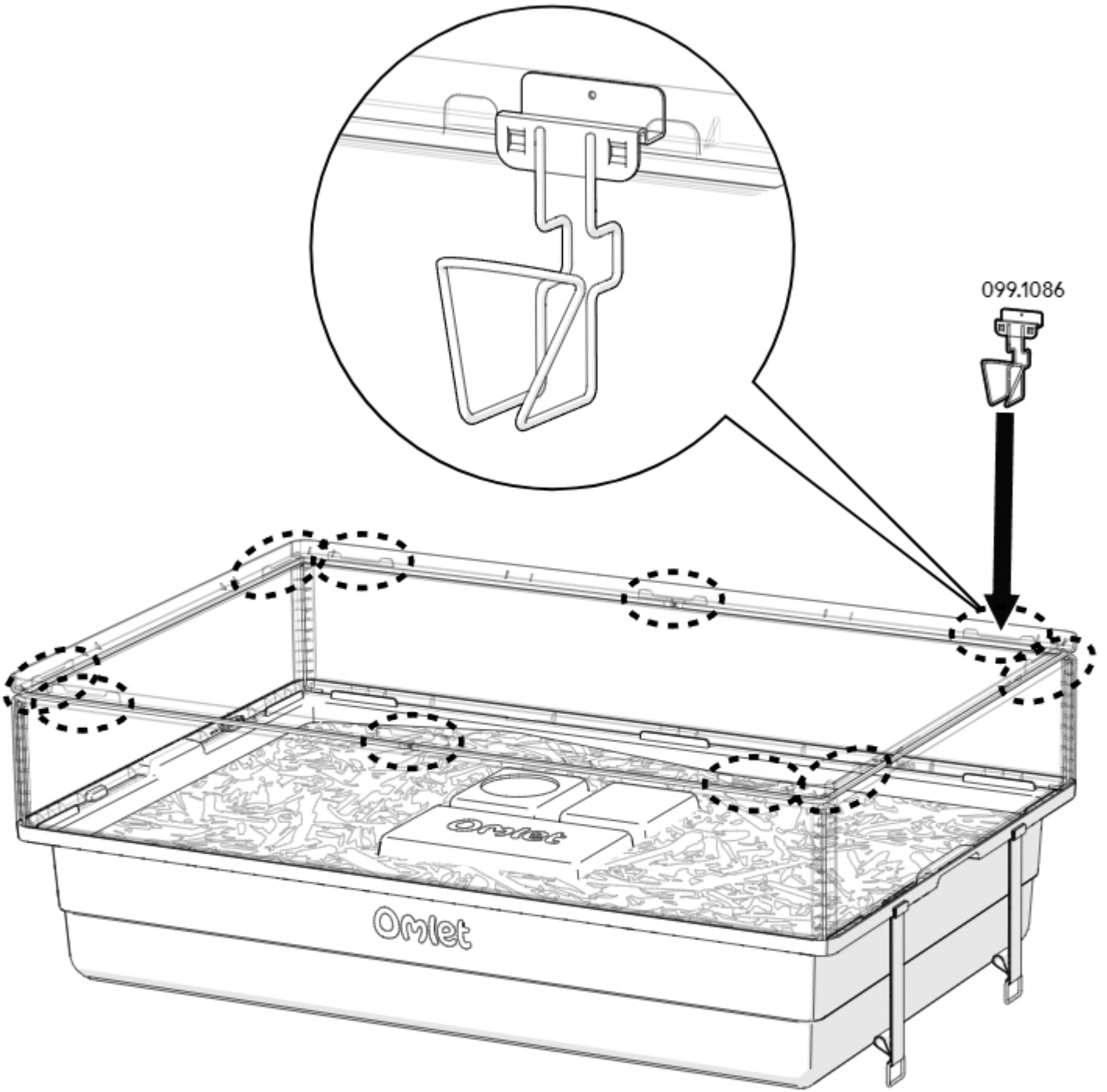

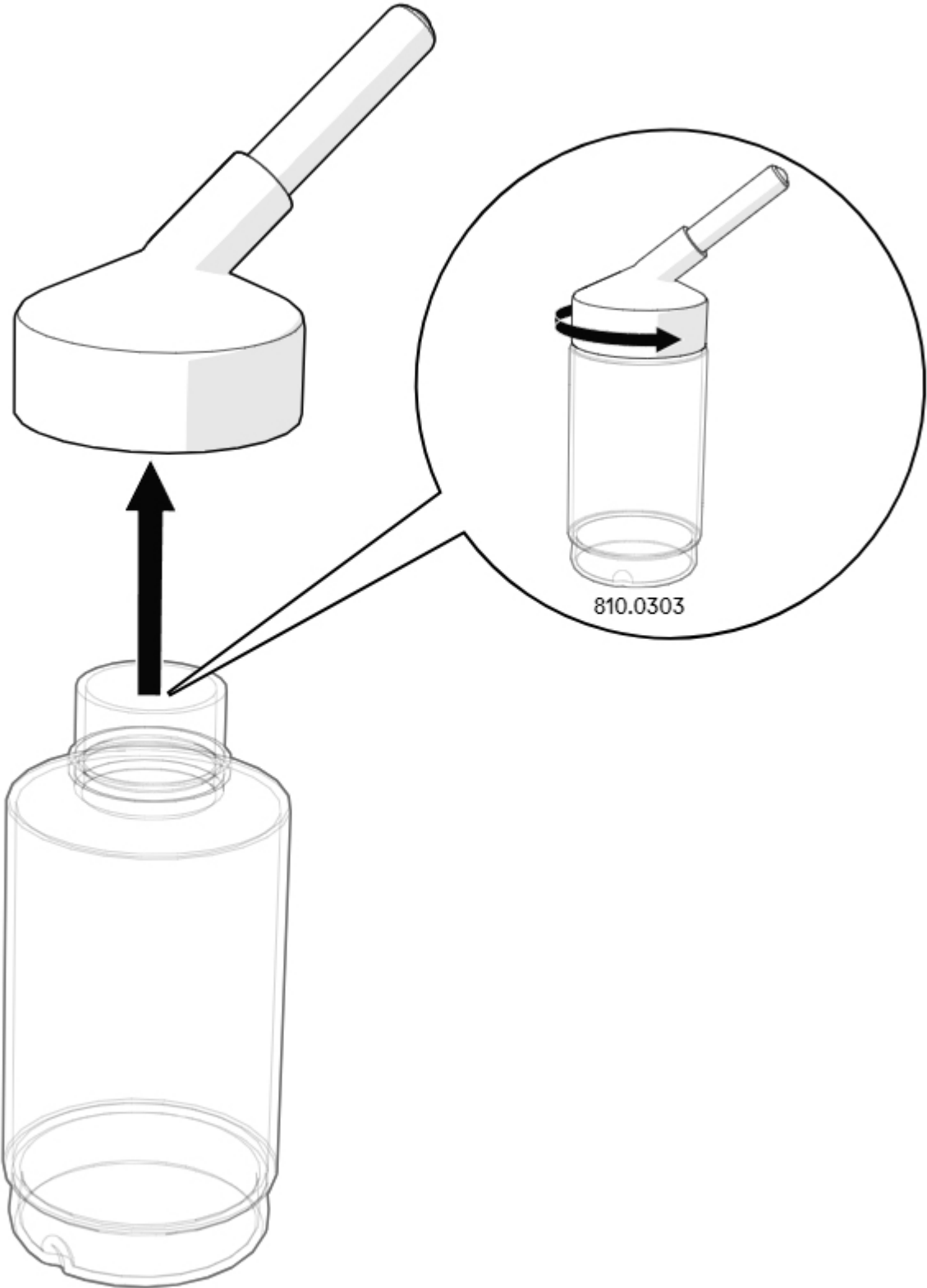

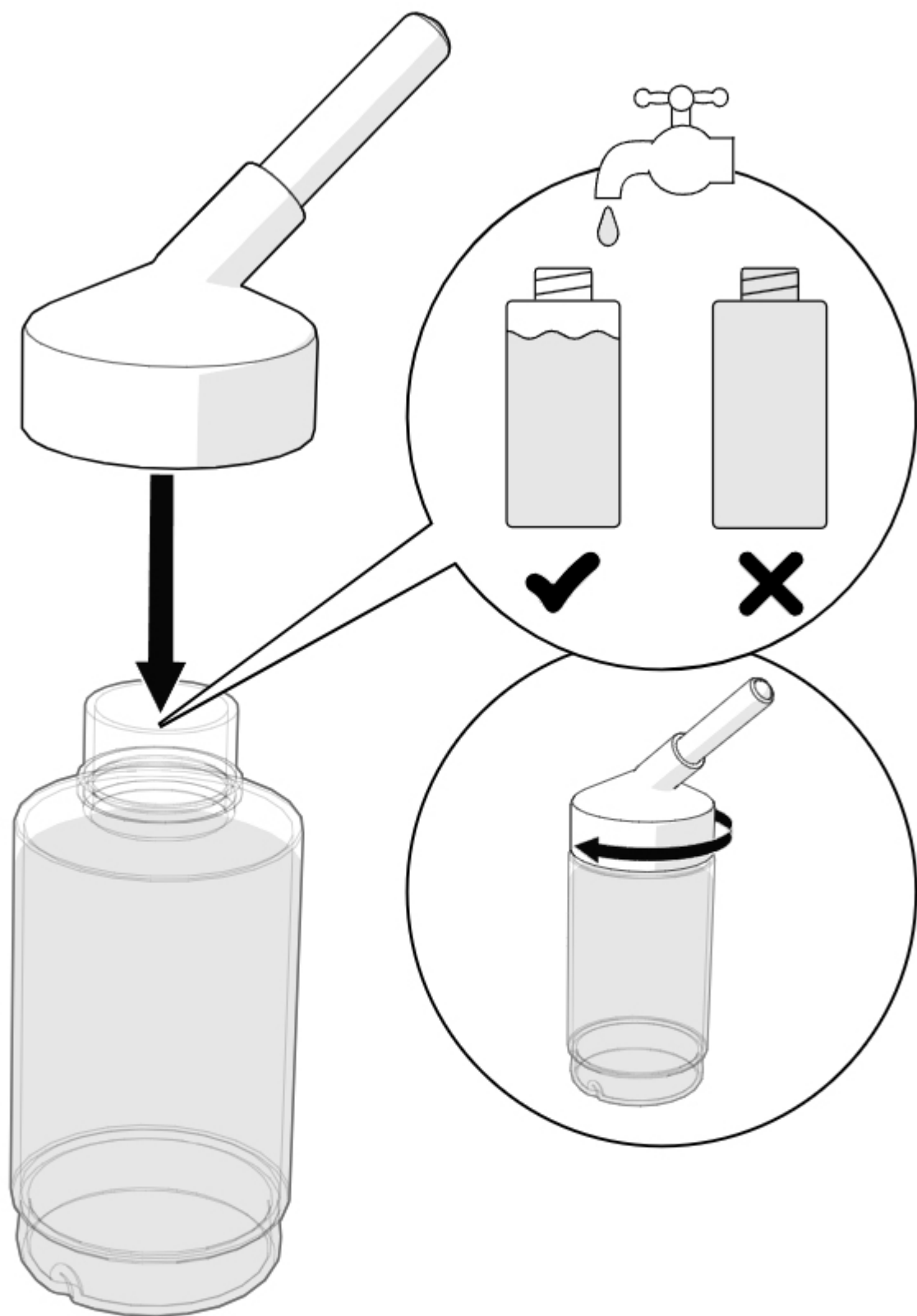

Shake and check there is not a continuous drip from the end of the bottle



- DE Schütteln und überprüfen Sie, dass die Flasche nicht ununterbrochen tropft
- FR Agitez et vérifiez qu'il n'y a pas d'écoulement continu à l'extrémité de la bouteille
- NL Schud en controleer of het uiteinde van de fles niet continue druppelt
- IT Agitare e controllare che non ci siano delle perdite continue dall'estremità del beverino
- SE Skaka och kontrollera att det inte droppar kontinuerligt från flaskan
- DK Ryst og kontroller, at der ikke er et kontinuerligt dryp fra enden af flasken

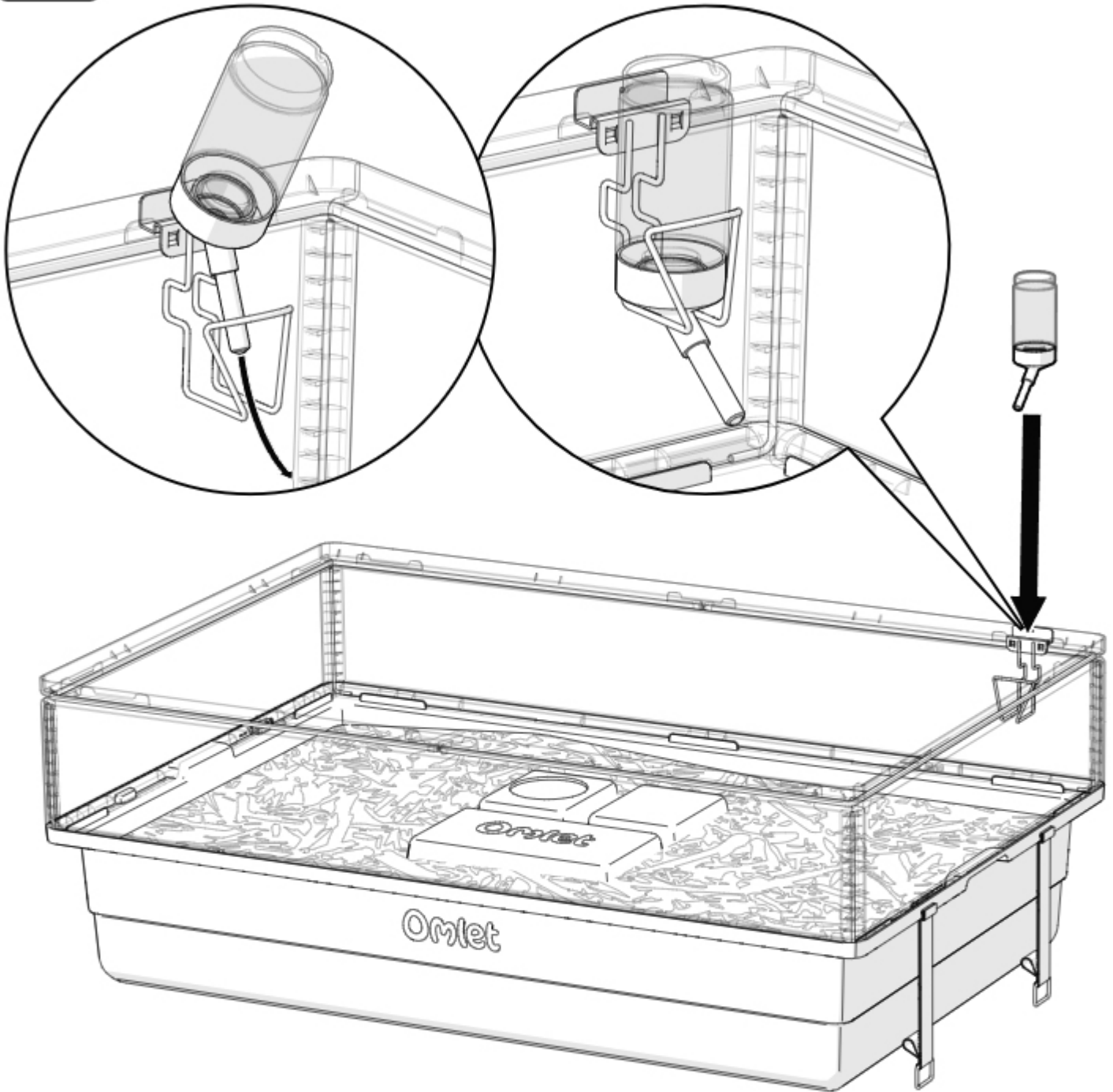

Check that your hamster can reach the bottle and top up bedding level if necessary



- **DE** Überprüfen Sie, ob Ihr Hamster die Flasche erreichen kann füllen Sie bei Bedarf die Einstreu nach
- **FR** Vérifiez que votre hamster peut atteindre la bouteille et ajoutez de la litière si nécessaire
- **NL** Controleer of uw hamster de fles kan bereiken en vul het bodemmateriaal indien nodig bij
- **IT** Controlla che il tuo criceto possa raggiungere la bottiglia e aggiungere altra lettiera se necessario
- **SE** Kontrollera att din hamster kan nå flaskan och fyll på mer strö om det behövs
- **DK** Tjek at din hamster kan nå flasken og tilføj mere bundmateriale, hvis det er nødvendigt

Add food to the Hamster Food Bowl (810.0229) - you can scatter food around the habitat to provide extra enrichment for your hamster

DE Füllen Sie den **Hamster Food Bowl (810.0229)** mit Futter – für zusätzliche Bereicherung können Sie auch im Heim des Hamsters Futter verstreuen

FR Ajoutez de la nourriture dans la **Hamster Food Bowl (810.0229)** – vous pouvez disperser de la nourriture dans la cage en guise d'enrichissement pour votre hamster

NL Voeg voeding toe aan de **Hamster Food Bowl (810.0229)** - u kunt voedsel verspreiden in het verblijf om de hamster extra verrijking te bieden.

IT Aggiungere del cibo nella **Hamster Food Bowl (810.0229)** - potete spargerlo all'interno della casetta per fornire ulteriori stimoli per il vostro animaletto

SE Lägg mat i **Hamster Food Bowl (810.0229)** - du kan också strö ut mat i buren för att ge din hamster extra berikning

DK Tilføj mad til **Hamster Food Bowl (810.0229)** - du kan sprede mad rundt i habitatet for at give ekstra berigelse til din hamster

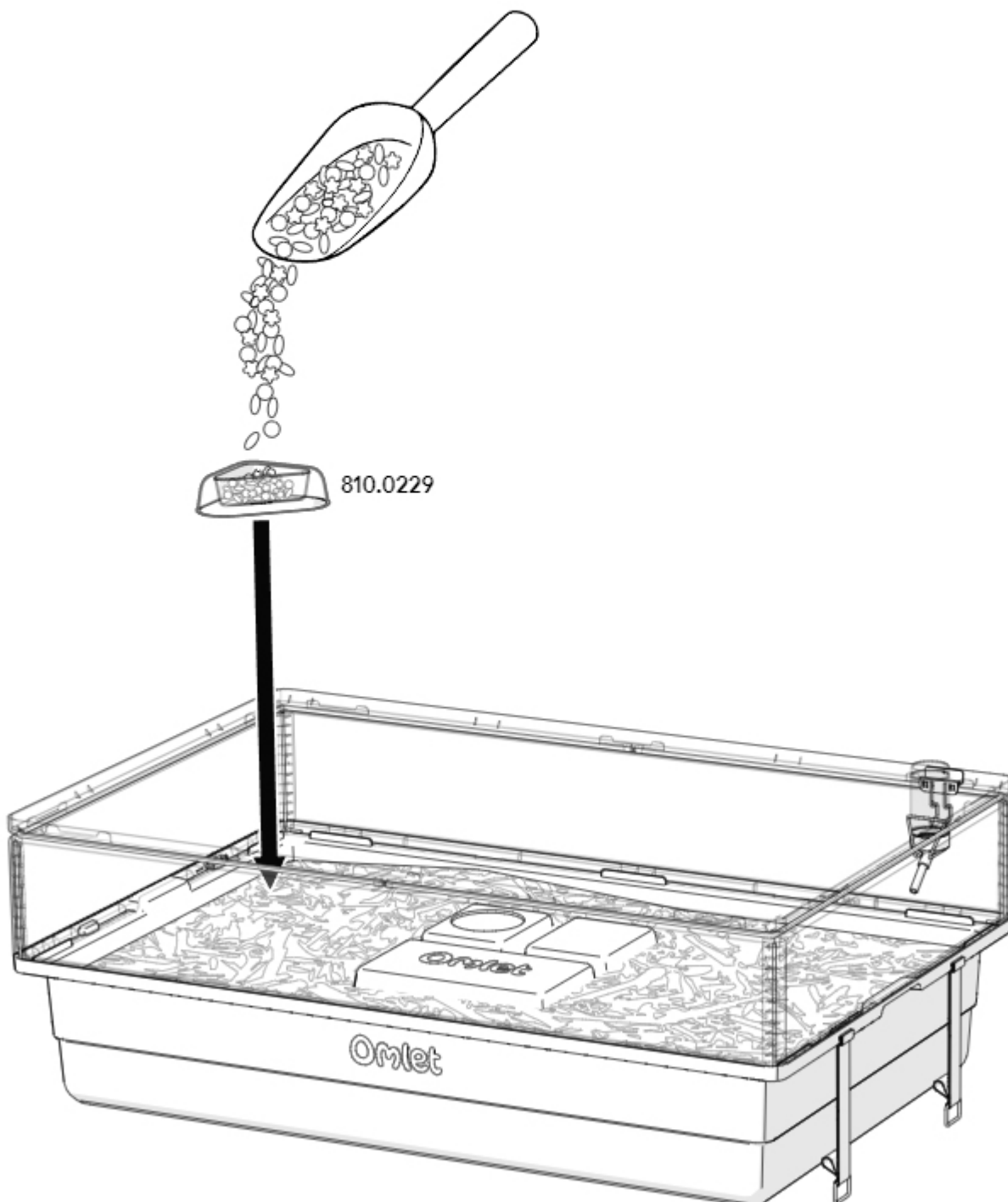

099.0023

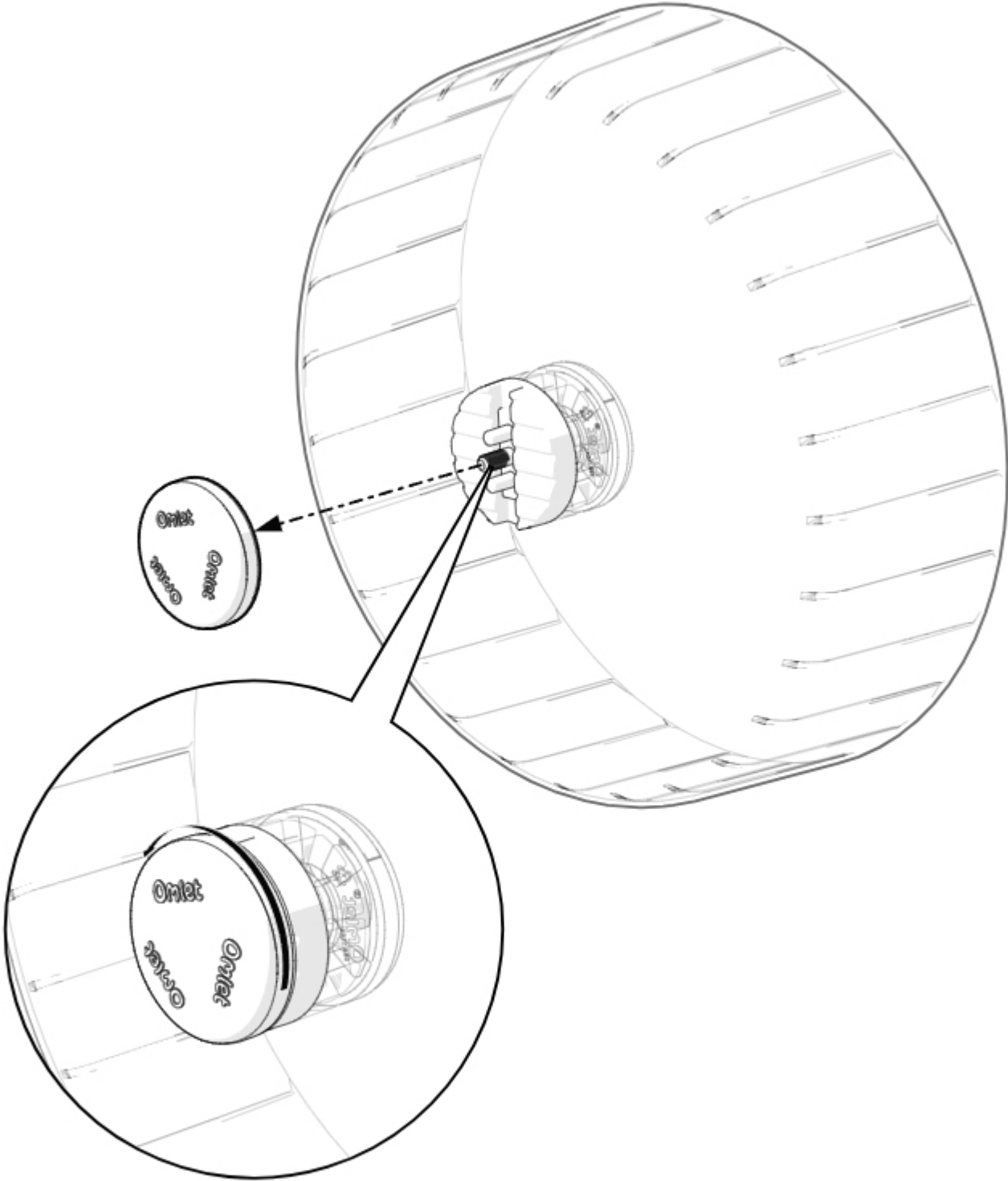

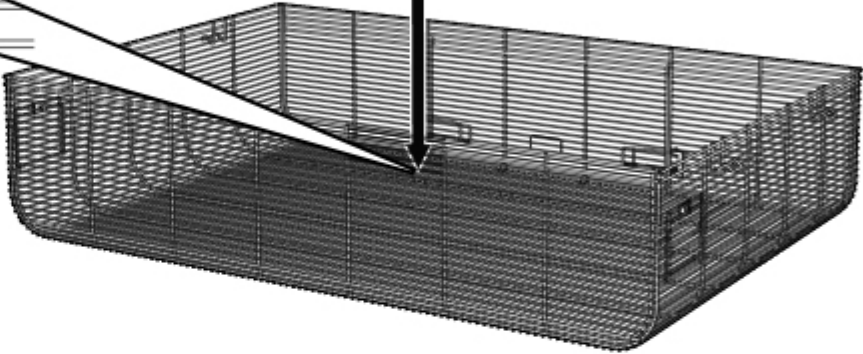
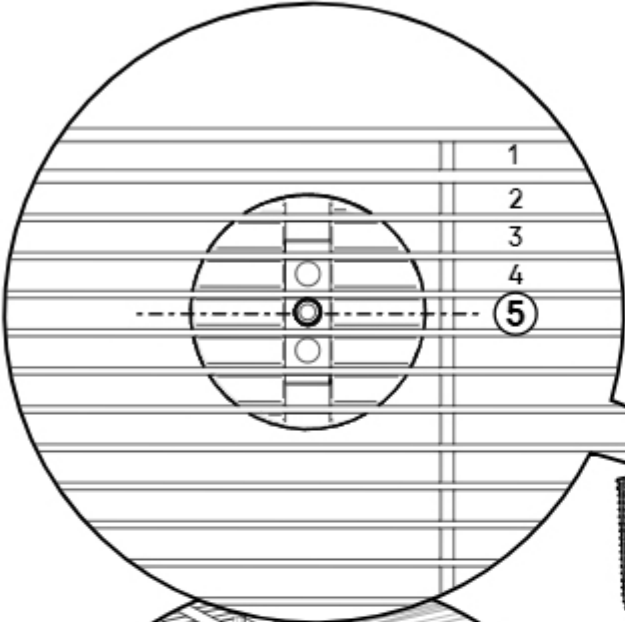
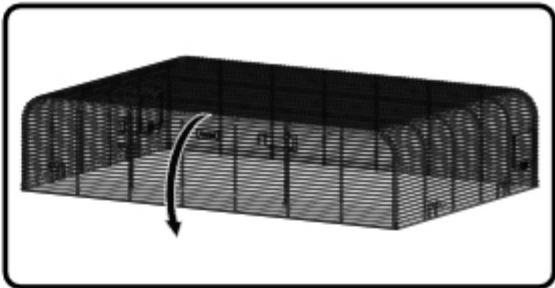

099.0001

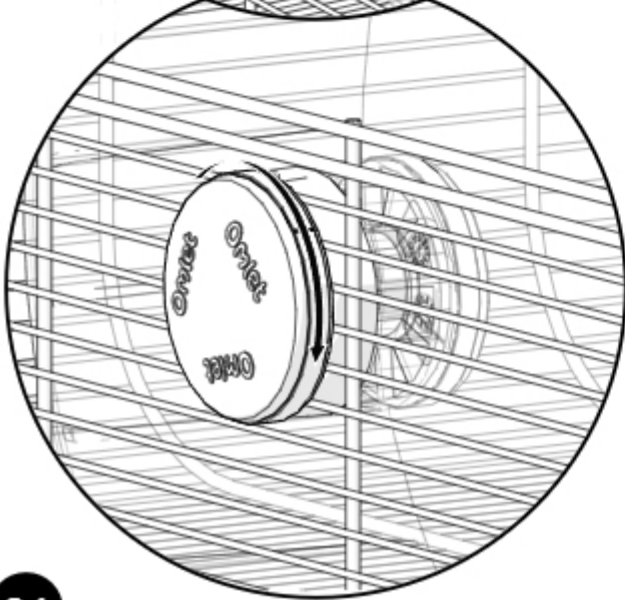
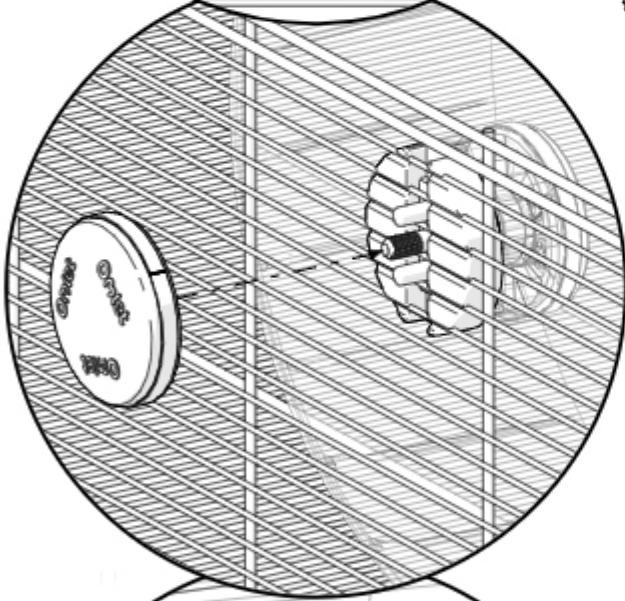

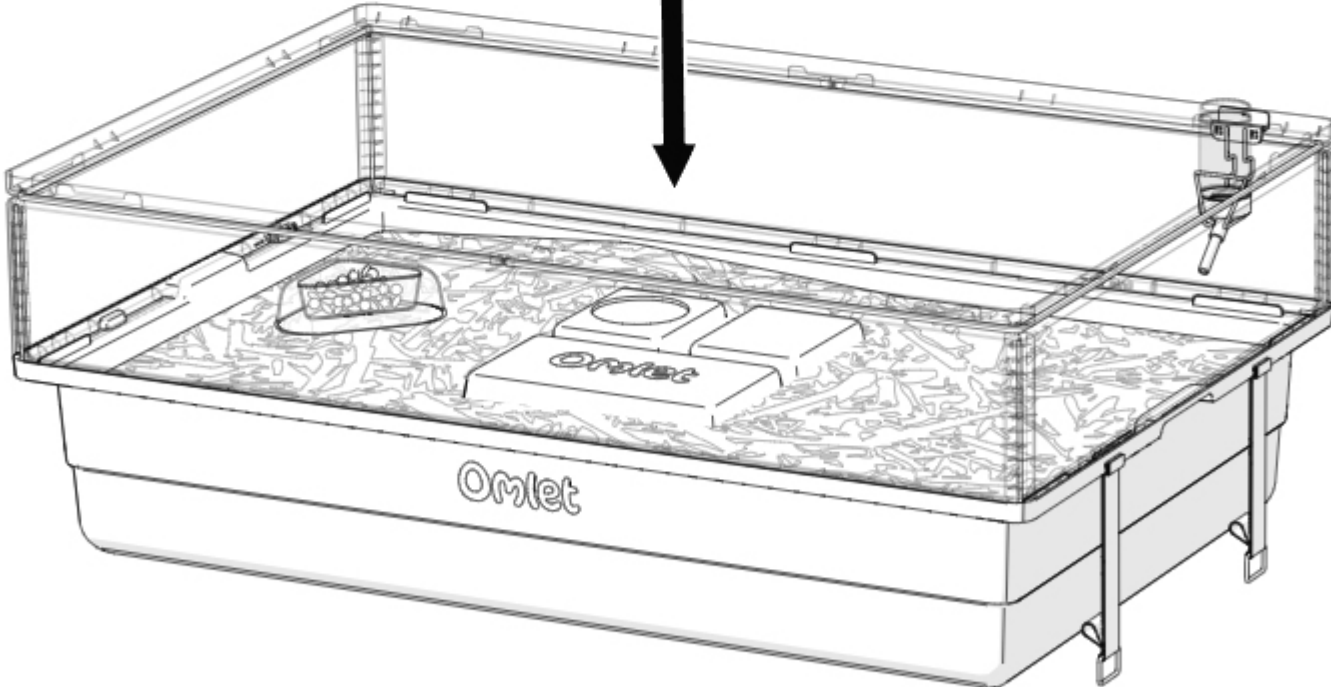
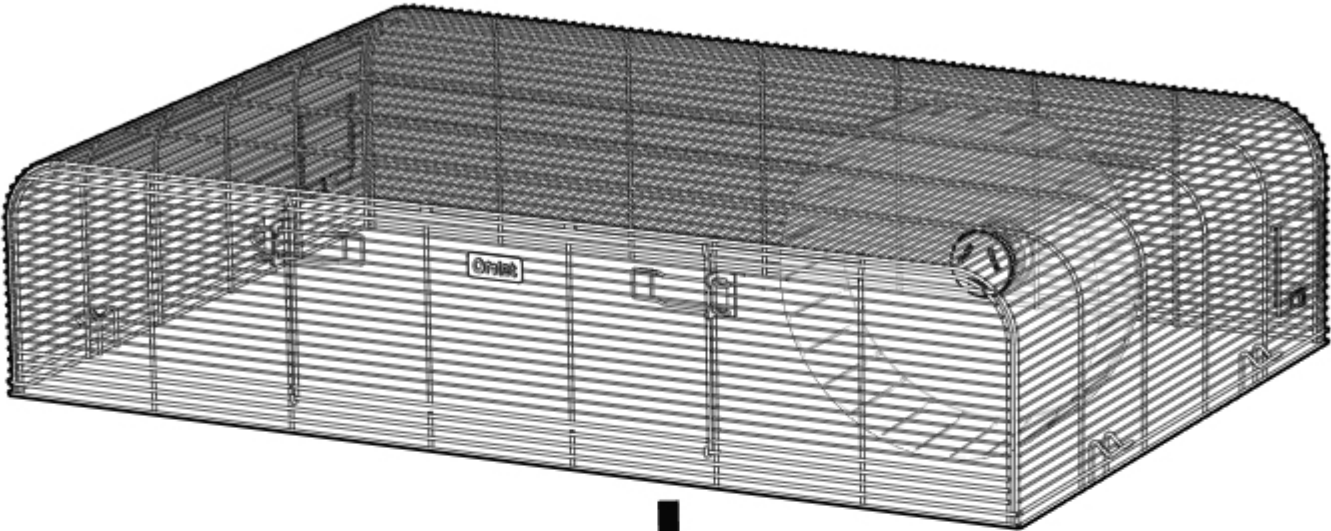
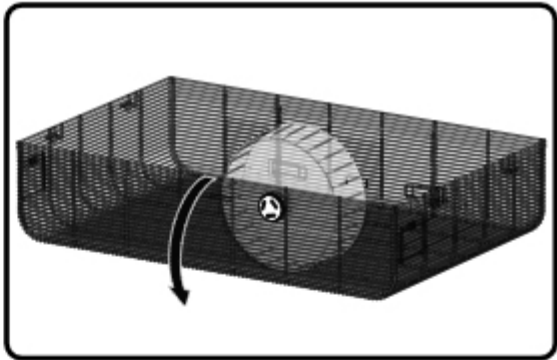

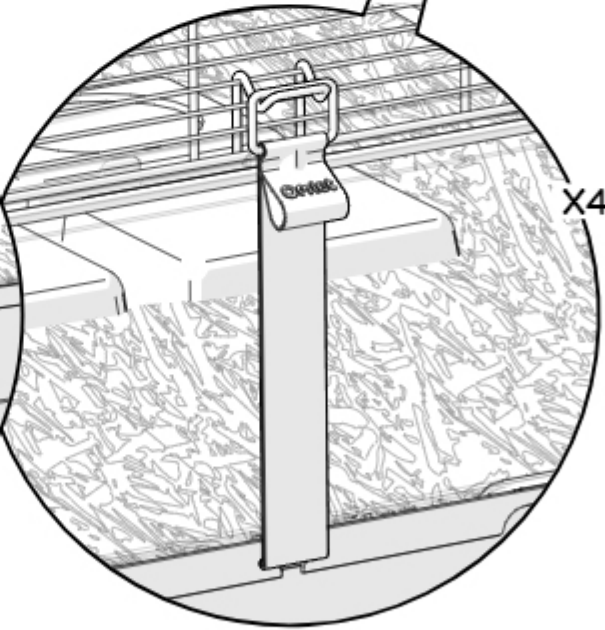
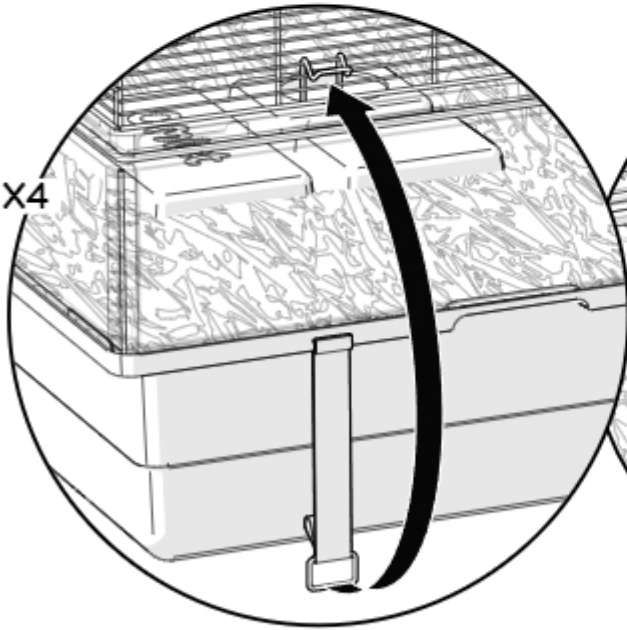
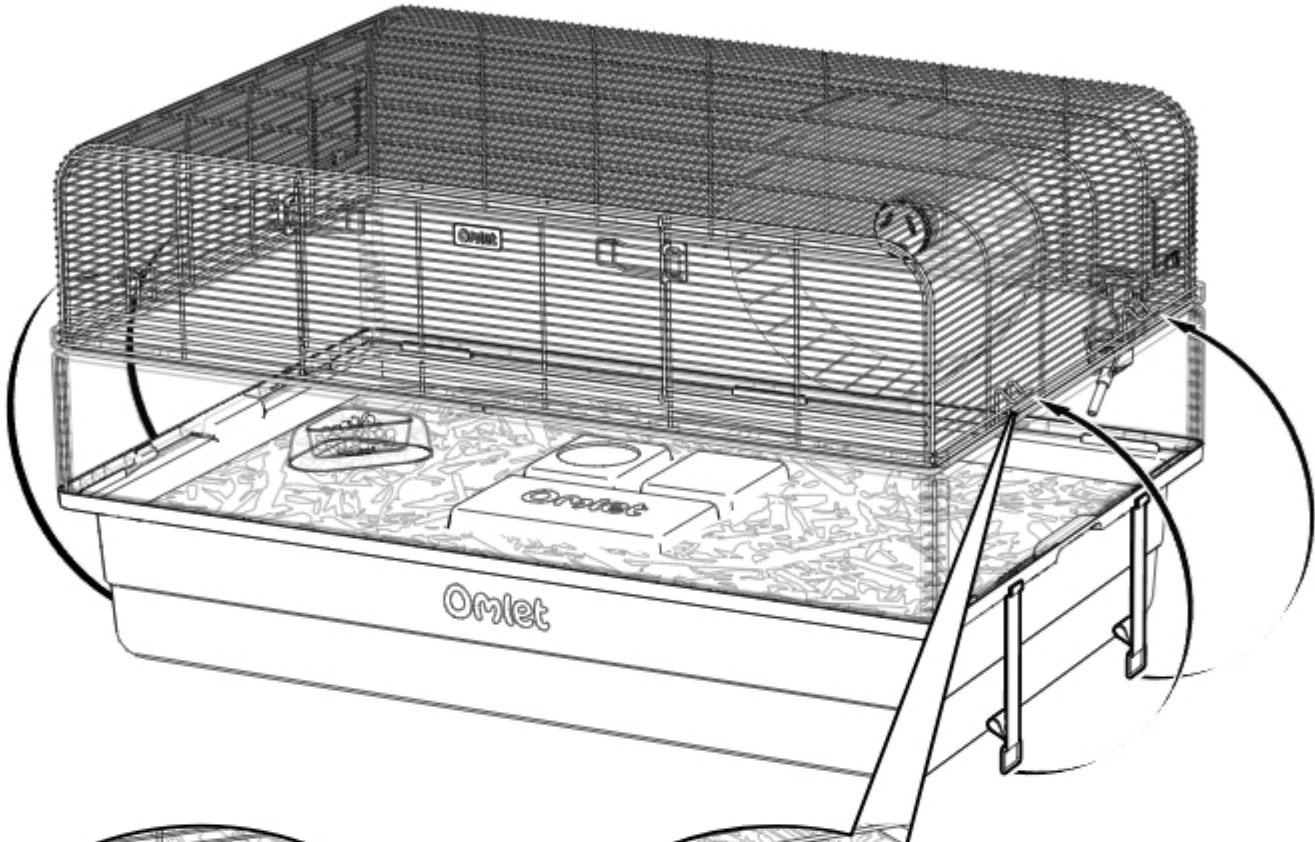

Using the door

DE Die Tür benutzen · FR Utiliser la porte · NL De deur gebruiken · IT Usando la porta · SE Använda dörren
DK Brug af døren

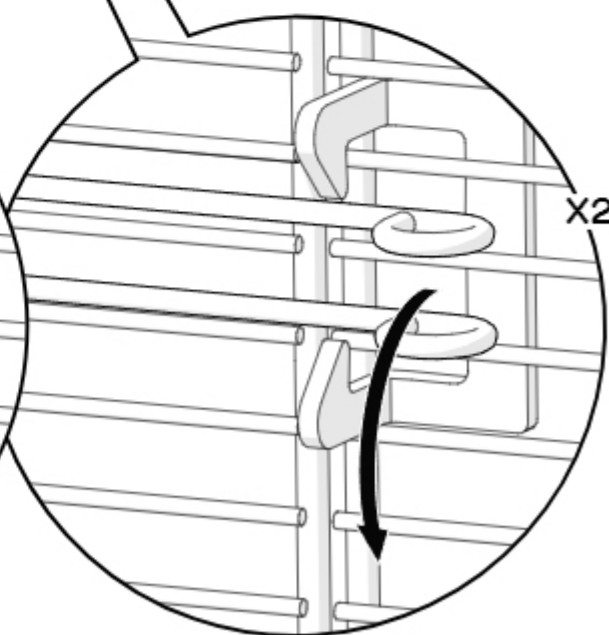
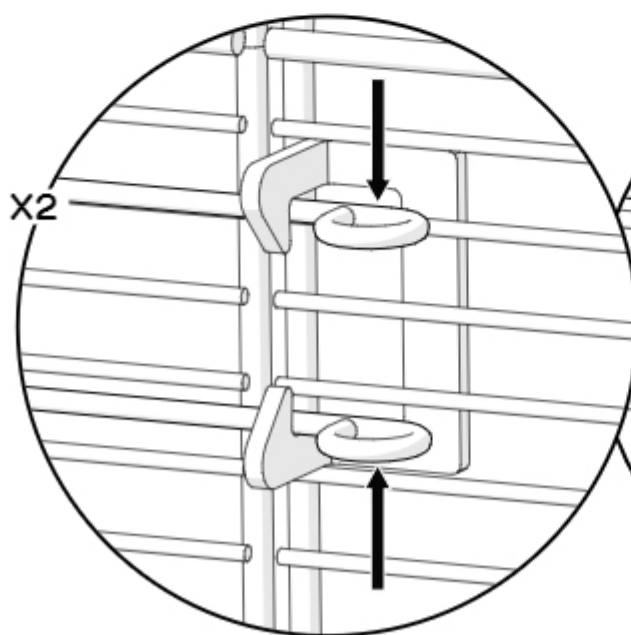
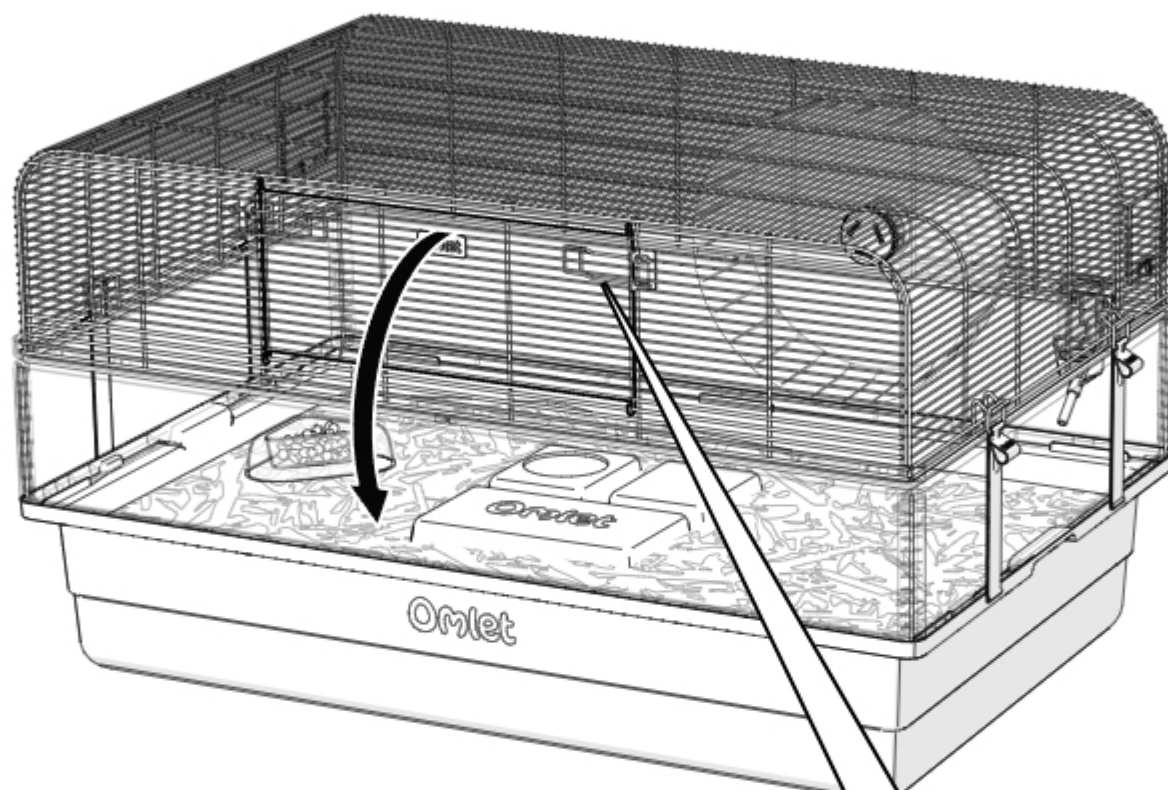

Daily Clean

DE Tägliche Reinigung · FR Nettoyage quotidien · NL Dagelijks schoon · IT Pulito quotidiano · SE Daglig rengöring
DK Daglig rengøring

1

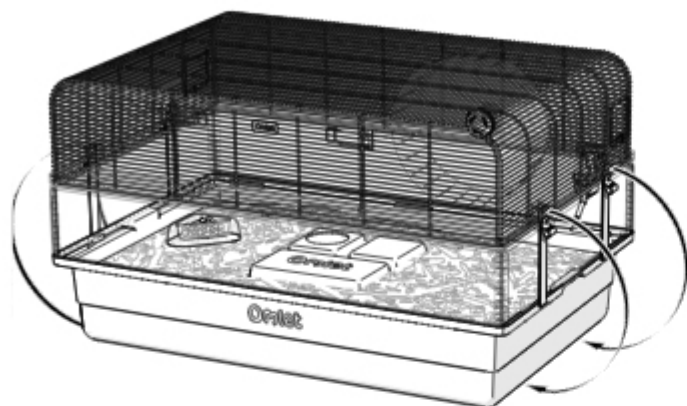

2

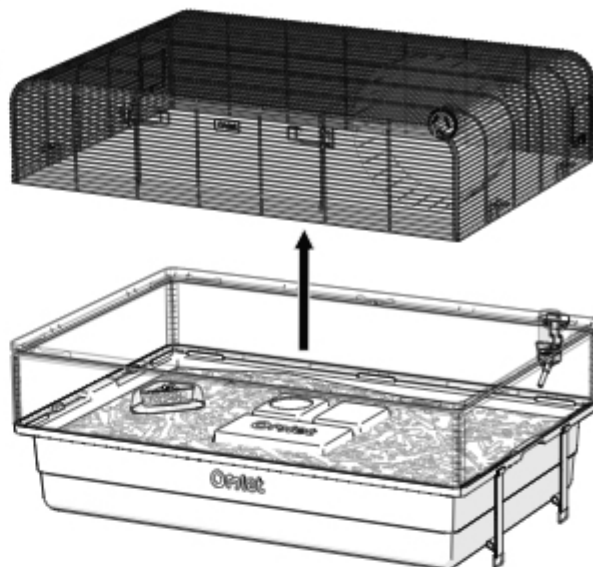

3

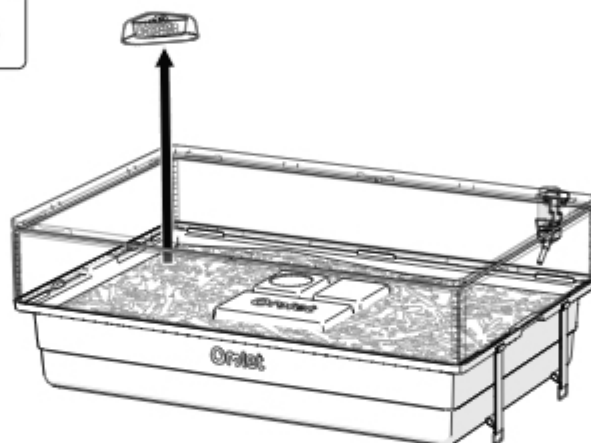

Remove soiled bedding - be careful not to disturb any tunnels your hamster has made in the bedding

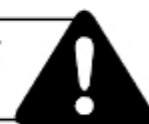

- DE Entfernen Sie verschmutzte Einstreu – achten Sie darauf, dass Sie die Tunnel, die Ihr Hamster in der Einstreu gebaut hat, nicht stören
- FR Retirez la litière souillée – veillez à ne pas détruire les tunnels que votre hamster a creusés dans la litière
- NL Verwijder vervuild bodem materiaal - wees voorzichtig en verstoor de eventuele tunnels die uw hamster heeft gemaakt niet
- IT Rimuovere la lettiera sporca - fare attenzione a non distruggere i tunnel che il vostro criceto potrebbe aver realizzato nella lettiera
- SE Ta bort smutsigt strö - var försiktig så att du inte förstör tunnlar som din hamster har grävt i ströet
- DK Fjern snavset bundmateriale - pas på ikke at ødelægge tunneler, som din hamster har lavet af bundmateriale

4

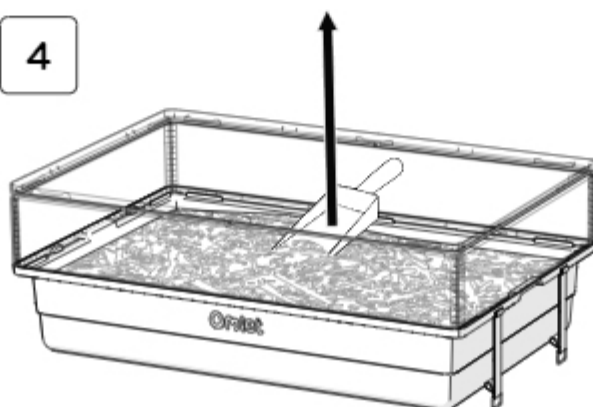

5

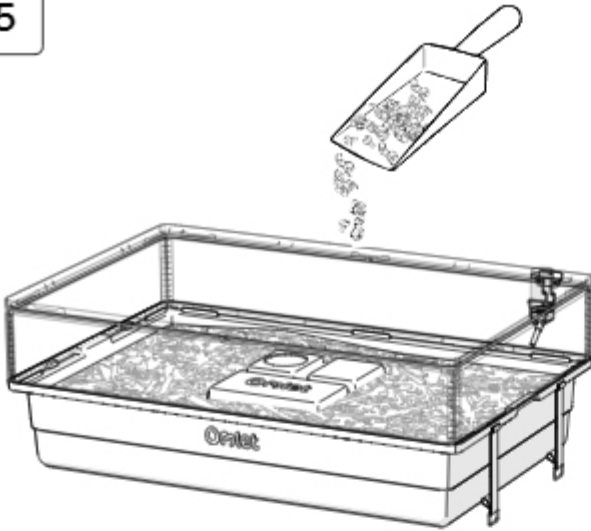

Top up bedding if necessary



- DE Füllen Sie bei Bedarf die Einstreu nach
- FR Rajoutez de la litière si nécessaire
- NL Vul het bodemmateriaal indien nodig bij
- IT Aggiungere altra lettiera se necessario
- SE Fyll på mer strö om det behövs
- DK Tilføj mere bundmateriale, hvis det er nødvendigt

6

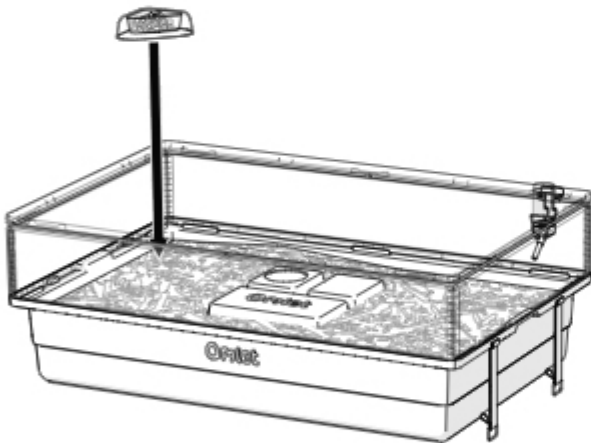

7

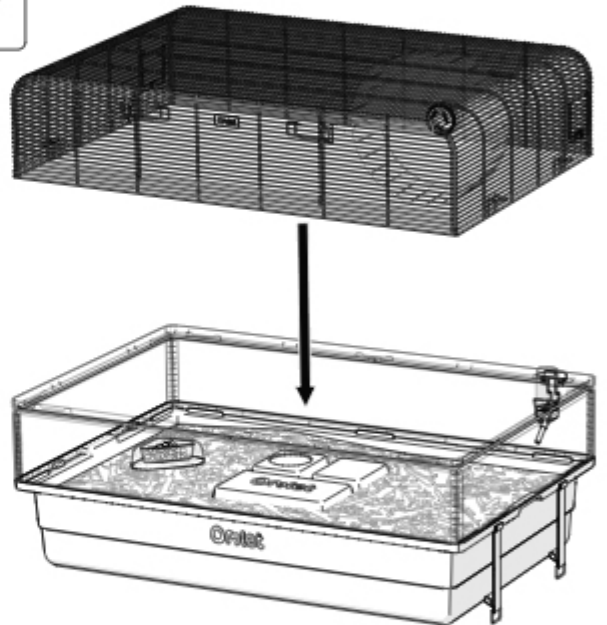

8

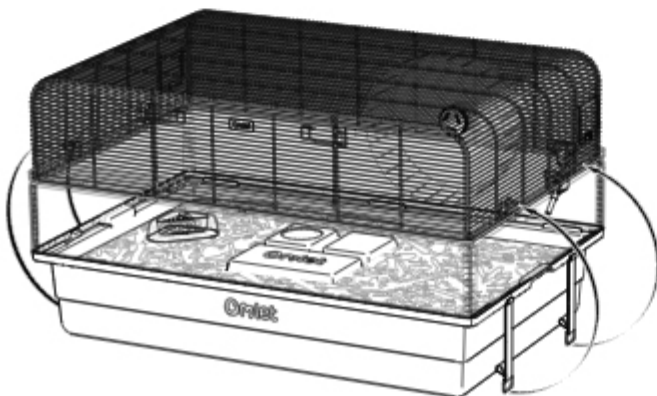

Full Clean - You should disassemble and clean all removable parts at least once a month

DE Vollständige Reinigung - Mindestens einmal im Monat solltest Du alle abnehmbaren Einzelteile demontieren und gründlich säubern

FR Nettoyage complet - Démontez et nettoyez toutes les pièces détachables au moins une fois par mois

NL Grondige schoonmaak- U dient minstens eens per maand alle losse onderdelen te demonteren en reinigen

IT Pulizia completa - Si raccomanda di tirare fuori e pulire a fondo tutte le parti rimovibili (es. tubo, ruota, etc...) almeno una volta al mese

SE Ordentlig rengöring - Du bör ta isär och rengöra alla borttagbara delar åtminstone en gång i månaden

DK Fuld rengøring - Du bør skille buret ad og rengøre alle delene mindst en gang om måneden

1

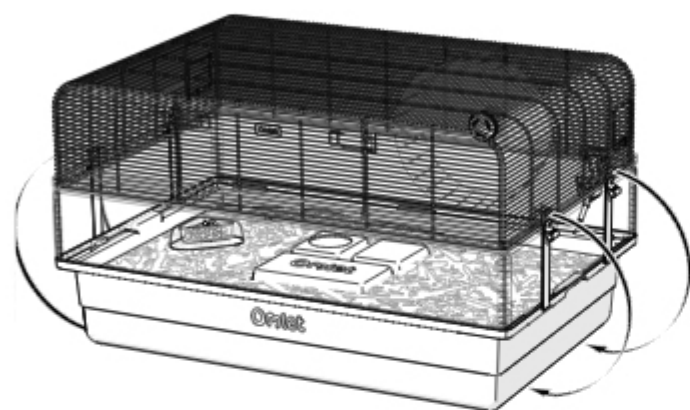

2

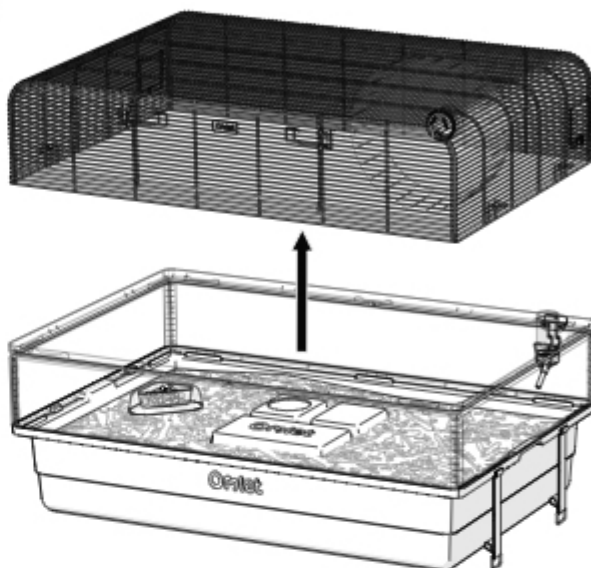

3

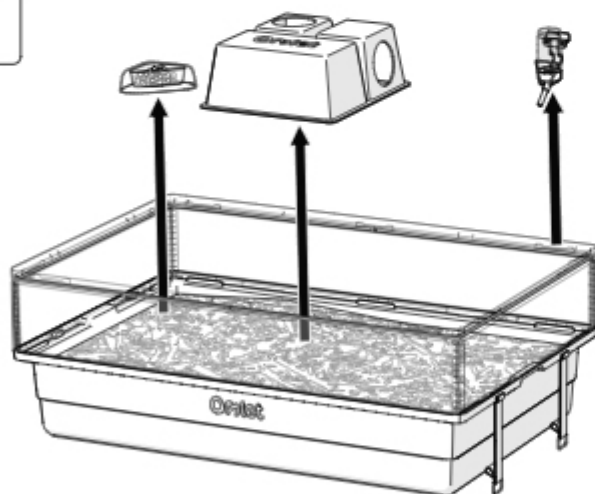

4

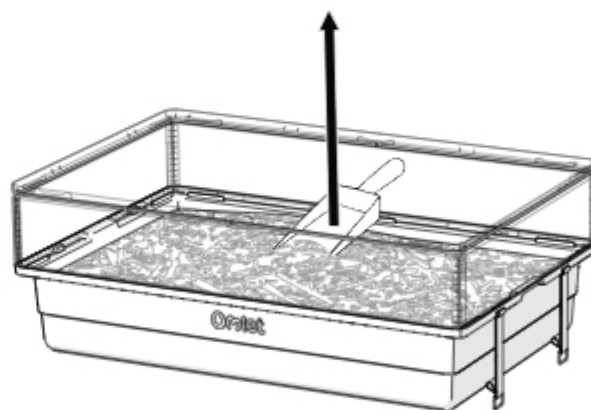

Save some bedding with your hamsters scent to add into new bedding



- **DE** Heben Sie etwas Einstreu mit dem Duft Ihres Hamsters auf, um es der neuen Einstreu beizufügen
- **FR** Conservez un peu de litière avec l'odeur de votre hamster pour l'ajouter à la nouvelle litière propre
- **NL** Bewaar wat bodemmateriaal met de geur van uw hamster en voeg dit toe aan het nieuwe bodemmateriaal
- **IT** Conservare un po' di lettiera con l'odore del vostro criceto da aggiungere alla lettiera pulita
- **ES** Guarde un poco de lecho con el olor de su hámster para añadirlo al lecho limpio
- **SE** Spara lite strö med din hamsters doft för att lägga till i det nya ströet
- **DK** Gem noget bundmateriale med din hamsters doft som du kan tilføje til nyt bundmateriale
- **NO** Spar litt underlag med hamsterens doft som du kan legge til nytt underlag
- **PL** Zachowaj trochę starej ściółki z zapachem chomika, aby zmieszać ją z nową ściółką

5



6



7

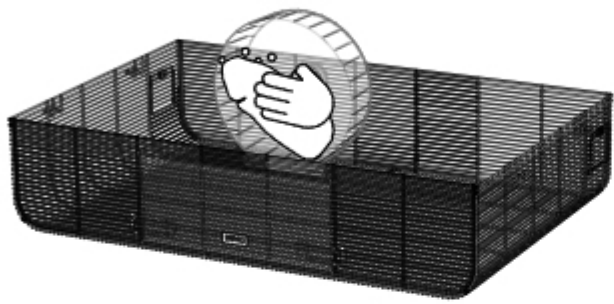

8

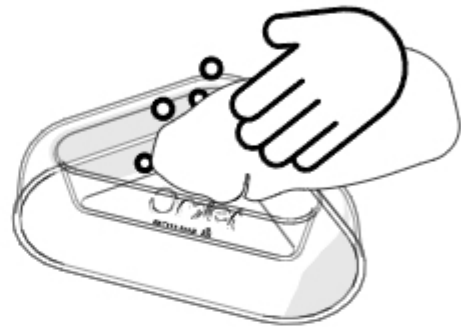

9

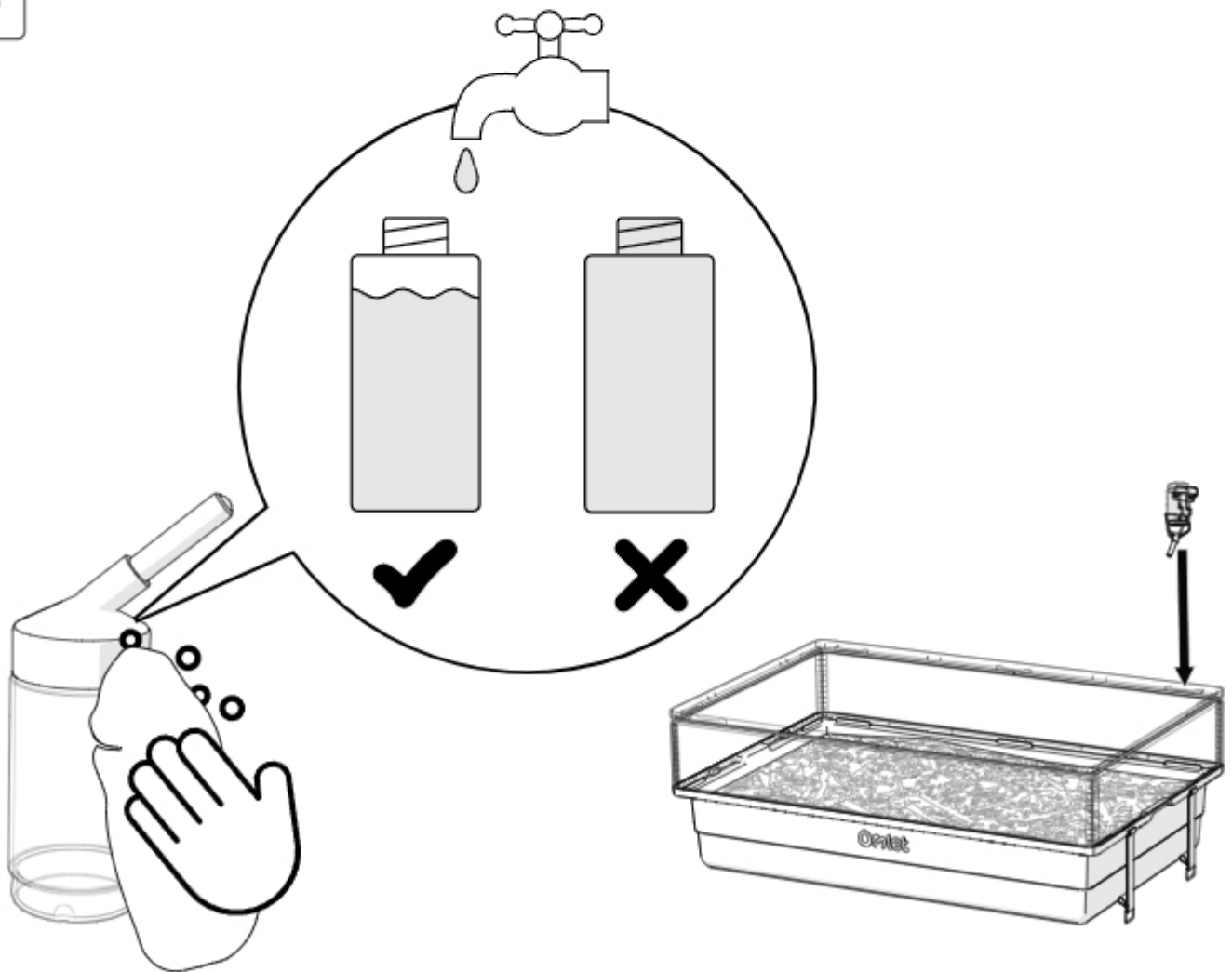

10

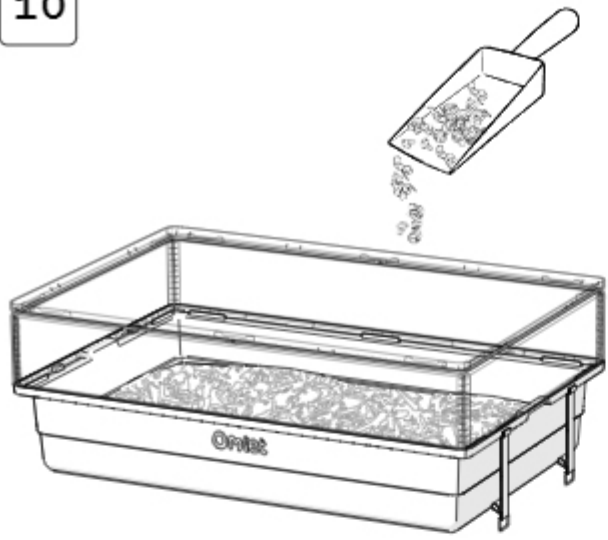

11

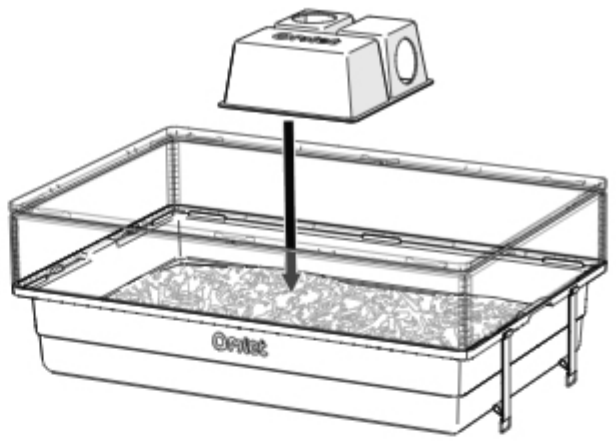

12

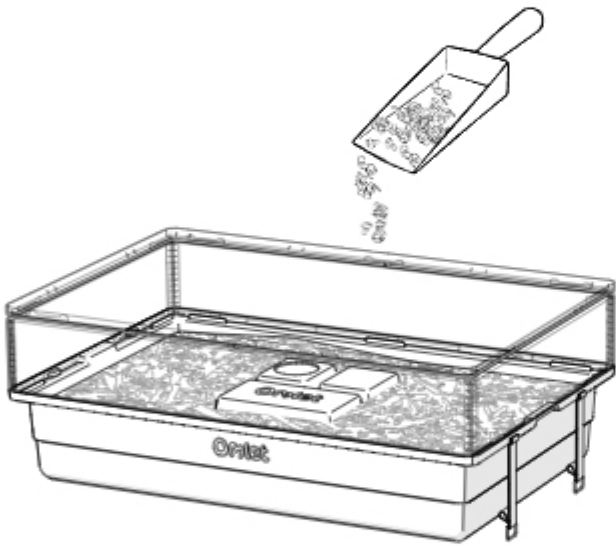

13

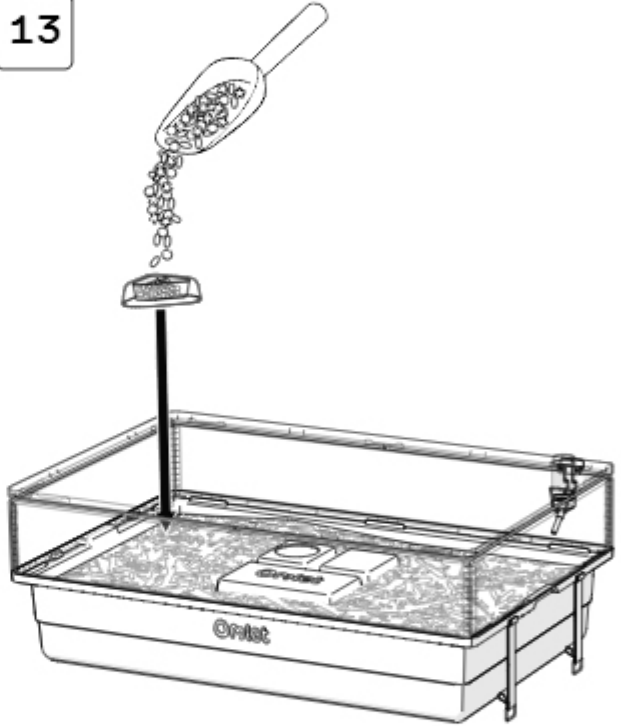

14

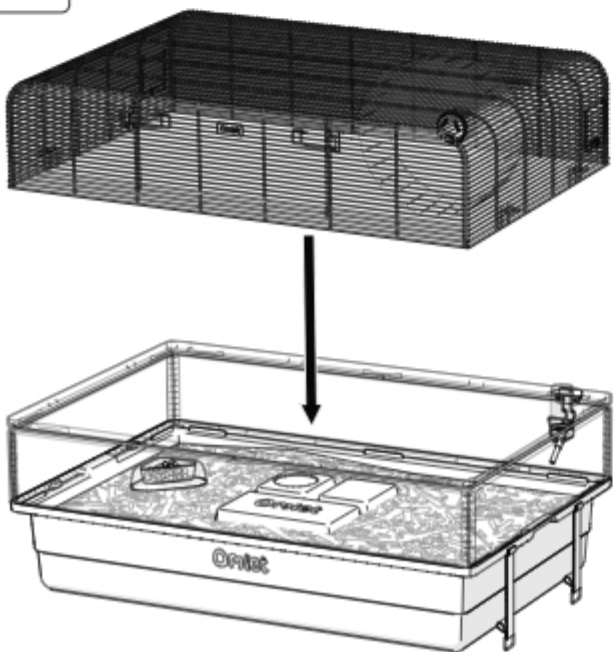

15

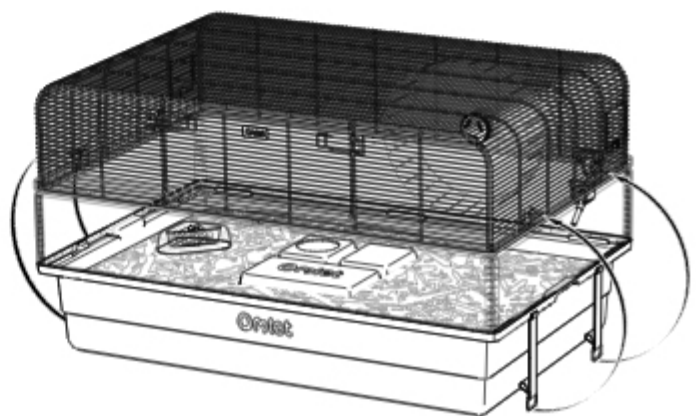

• DOs and DON'Ts •

DOs

- Follow the assembly instructions to make sure that the product works as intended.
- Give your pets access to fresh feed and water at all times.
- Use a non-abrasive pet safe disinfectant and soft cloth to clean your Hamster Habitat.
- Call or email us if you need further advice.

DON'Ts

- You should not place your Hamster Habitat in drafty, damp or wet conditions or in direct sunlight.
- You should not use your Hamster Habitat for transporting your pet.
- You should not sit, stand or climb on your Hamster Habitat.
- The Hamster Habitat is not a toy.

DE

• Verhaltensregeln •

Gebote

- Folge der Aufbauanleitung um sicherzugehen, dass dein Produkt wie vorgesehen funktioniert.
- Stelle deinen Haustieren jeder Zeit frisches Wasser und frisches Futter zur Verfügung.
- Benutze ein nicht scheuerndes und tierfreundliches Reinigungsmittel und ein weiches Tuch, um deinen Hamster Habitat zu säubern.
- Ruf uns an oder schreib uns eine E-Mail für weitere Ratschläge.

Verbote

- Du solltest deinen Hamster Habitat nicht dort platzieren, wo dein Haustier Zugluft, Feuchtigkeit oder direktem Sonnenlicht ausgesetzt ist.
- Du solltest deinen Hamster Habitat nicht zum Transport deines Tieres benutzen.
- Du solltest nicht auf dem Hamster Habitat sitzen, stehen oder auf ihn klettern.
- Der Hamster Habitat ist kein Spielzeug.

FR

• Les choses à faire et à ne pas faire •

À faire

- Suivez les instructions de construction pour vous assurer que le produit fonctionne comme il se doit.
- Donnez toujours à vos animaux de quoi boire et manger.
- Utilisez un désinfectant non abrasif pour animaux de compagnie et un chiffon doux pour nettoyer votre Hamster Habitat.
- Appelez-nous ou envoyez-nous un e-mail si vous avez besoin de conseils supplémentaires.

À ne pas faire

- Vous ne devez pas placer votre Hamster Habitat dans des courants d'air, dans un endroit humide ou à la lumière directe du soleil.
- Vous ne devriez pas utiliser votre Hamster Habitat pour transporter votre animal de compagnie.
- Vous ne devriez pas vous asseoir, vous tenir debout ou grimper sur votre Hamster Habitat.
- La cage Hamster Habitat n'est pas un jouet.

NL

• Wat wel en wat niet? •

Do's

- Volg de montagehandleiding om ervoor te zorgen dat het product werk zoals bedoeld.
- Zorg er altijd voor dat uw huisdieren voldoende voer en water tot hun beschikking hebben.
- Gebruik voor het reinigen van uw Hamster Habitat een niet-schurend, diervriendelijk desinfecteermiddel en een zachte doek.
- Bel of e-mail ons indien u meer advies wenst.

Don'ts

- Plaats uw Hamster Habitat niet in een tochtige, vochtige of natte omgeving en plaats niet in direct zonlicht.
- Gebruik uw Hamster Habitat niet om uw huisdier in te vervoeren.
- Zit, sta of klim nooit op uw Hamster Habitat.
- De Hamster Habitat is geen speelgoed.

Cosa fare

- Si raccomanda di seguire attentamente le istruzioni così da essere sicuri che il prodotto sia assemblato e funzioni correttamente.
- Fate in modo che i vostri animali abbiano sempre accesso a cibo e acqua fresca.
- Per pulire il Hamster Habitat usate un panno soffice e un detergente delicato e adatto agli animali.
- Se avete dubbi o domande non esitate a contattare il nostro Servizio Clienti.

Cosa non fare

- Non posizionare la gabbia Hamster Habitat in ambiente umido, con correnti d'aria o esposto alla luce diretta del sole.
- Non usate il Hamster Habitat per portare in giro il vostro animale. Il Hamster Habitat non sostituisce il trasportino.
- Non sedersi, arrampicarsi o montare sopra alla gabbia Hamster Habitat.
- Der Hamster Habitat ist kein Spielzeug.

Gör

- Följ monteringsinstruktionerna så att du är säker på att produkten fungerar som den ska.
- Se till att dina husdjur alltid har tillgång till mat och färskt vatten.
- Använd ett husdjurssäkert desinfektionsmedel och en mjuk trasa för att rengöra din Hamster Habitat.
- Ring eller mejla oss om du har frågor eller funderingar.

Inte gör

- Du bör inte ställa din Hamster Habitat på dragiga, fuktiga eller våta platser, eller i direkt solljus.
- Du bör inte använda din Hamster Habitat för att transportera ditt husdjur.
- Du bör inte sitta, stå eller klättra på din Hamster Habitat.
- Hamster Habitat är inte en leksak.

Gør

- Følg samlevejledningen for at sikre dig, at produktet fungerer som det skal.
- Sørg for at dine dyr altid har adgang til frisk vand og foder.
- Anvend et ikke-slibende, dyrevenligt desinfektionsmiddel og en blød klud til at rengøre dit Hamster Habitat.
- Ring eller send os en mail hvis du har nogen spørgsmål eller brug for rådgivning.

Ikke gør

- Du bør ikke placere dit Hamster Habitat et sted, hvor der er træk, fugt eller ligefrem vådt, eller i direkte sollys.
- Du bør ikke anvende Hamster Habitat til transport af dit kæledyr.
- Du bør ikke sidde, stå eller klatre på dit Hamster Habitat.
- Hamster Habitat er ikke et stykke legetøj.

DON'T FORGET!

The final step is decorating your hamsters new home with our Omlet stickers!

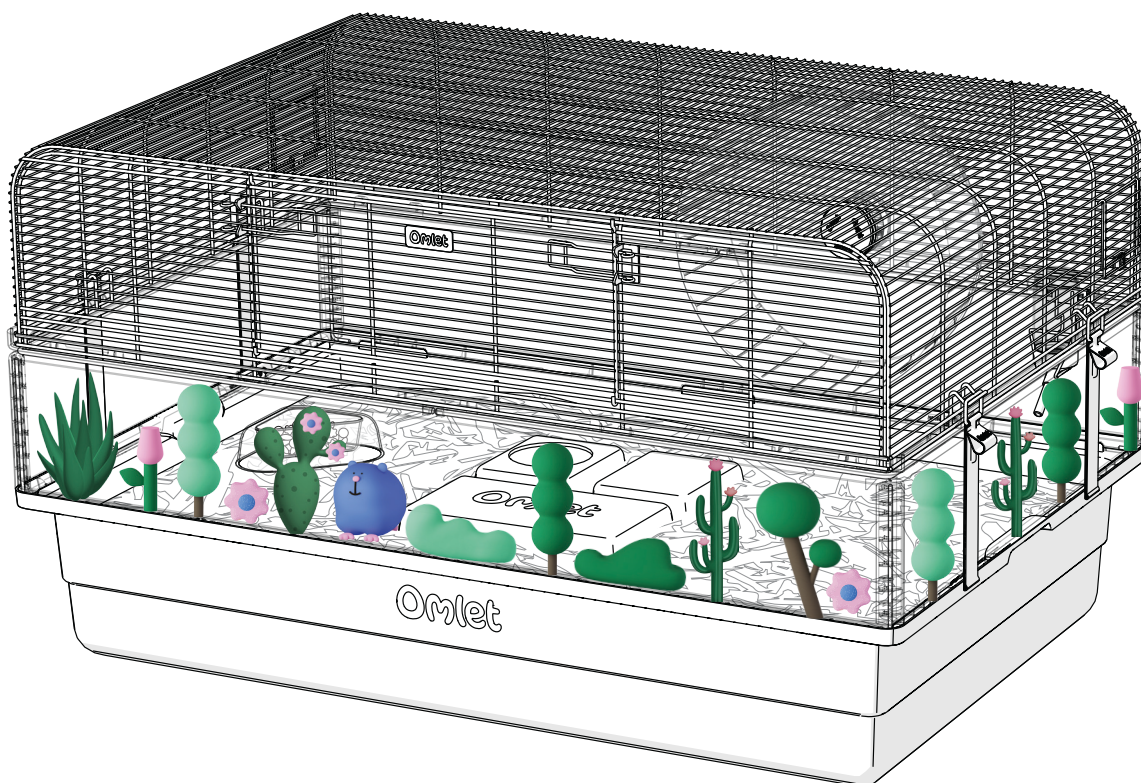
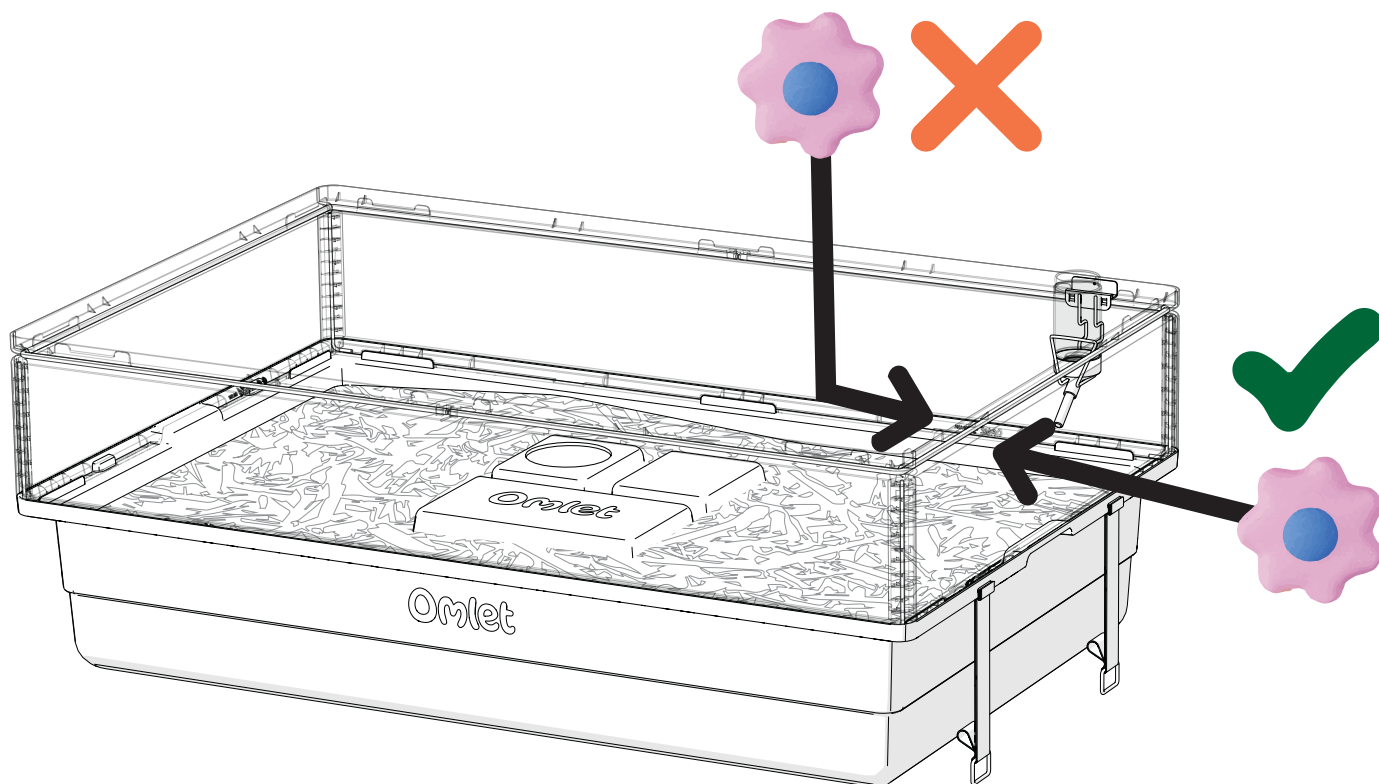

POWER TO LITTLE PETS

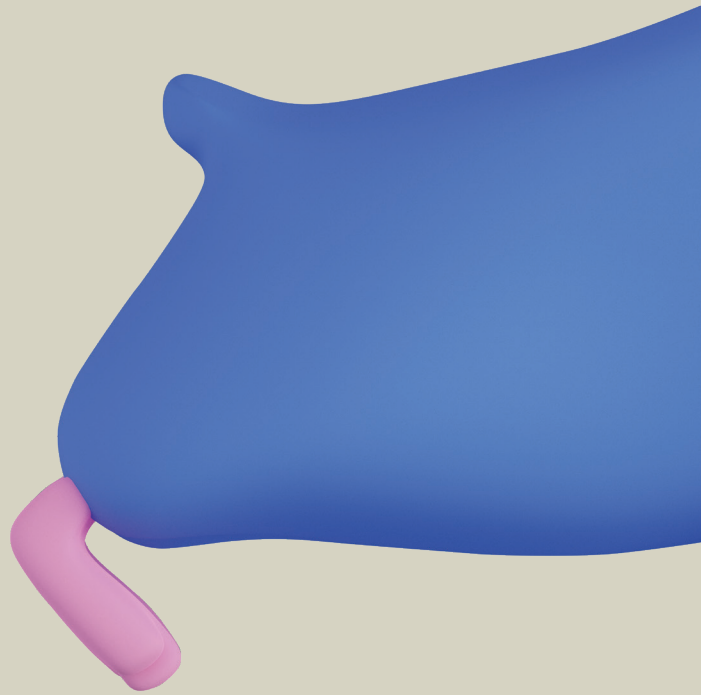

Omlet



Please
reuse &
recycle.

© Copyright Omlet Ltd. 2024
Design registered, patent pending
Omlet is a registered trademark of Hebe Studios Ltd.
820.2629 Instruction Manual Hamster Habitat 07/08/2024

