

SMART AUTODOOR

Assembly guide



Omlet

WE ASK. WE INVENT.

Watch the 'How to Build' video now

www.omlet.co.uk/how_to_build

Sehen Sie sich jetzt das 'Wie baut man?' Video an

Regardez maintenant le tutoriel d'assemblage

Bekijk nu de instructievideo

Guarda adesso il video di montaggio

Puedes ver el vídeo de montaje ahora

Titta på instruktionsvideon nu

Se instruktionsvideoen nu

Se instruksjonsvideoen nå

Obejrzyj teraz film instruktażowy



EN Important information! Please read before use

- Omlet's Autodoor is designed for use solely as an automated way to open and close access to a chicken coop. It is not a device that will care for your chickens. As the owner you will still need to carry out all the routine daily checks to ensure the health and safety of your chickens, such as ensuring your chickens have access to food and water.
- Please read the instruction manual provided before using this product.
- You must follow the assembly instructions to make sure the product works as intended.
- The product is only to be used for its intended purpose.
- There is a danger of trapping your chickens so keep the product free from dirt and obstructions in order to ensure correct operation of the crush detector.
- The Autodoor is designed for use with adult chickens. Disable product if there are chickens under 15 weeks of age in the chicken house.
- Check your chickens every morning to ensure they have access to food and water.
- Do not rely solely on this product to care for your chickens.
- Keep your fingers away from the moving door.
- Ensure excess cable is stowed to avoid tripping or accidental pulling.
- Make sure that the control panel is completely assembled before turning the power on.
- Do not disassemble the control panel when it is wet.
- Ensure that the product is securely attached before it is operated.
- Children must be supervised when using the Autodoor - it is not a toy.
- Any other use beyond what is specified shall be considered as improper use. Any direct commercial or industrial use is also deemed to be improper. Omlet is not liable for any damage resulting from such use. The user alone bears the risk.

DE Wichtige Informationen! Vor Gebrauch bitte lesen

- Omlets Automatische Hühnerstalltür ist lediglich zum Öffnen und Schließen eines Hühnerstalles gedacht. Sie wird nicht die Pflege der Hühner übernehmen. Als Besitzer der Tiere werden Sie sich auch weiterhin täglich um die Gesundheit und Sicherheit Ihrer Hühner kümmern müssen, dazu gehört zum Beispiel, dass Sie sicherstellen, dass die Tiere Zugang zu Futter und Wasser haben.
- Bitte lesen Sie die mitgelieferte Betriebsanleitung, bevor Sie dieses Produkt verwenden.
- Sie müssen der Montage- und Bedienungsanleitung folgen, um sicherzustellen, dass das Produkt wie vorgesehen funktioniert.
- Das Produkt ist nur für den vorgesehenen Zweck zu verwenden.
- Es besteht die Gefahr, dass Ihre Hühner eingeklemmt werden, halten Sie daher das Produkt frei von Schmutz und Hindernissen, um den korrekten Betrieb der Sicherheitssensoren zu gewährleisten, die dies verhindern sollen.
- Die Autodoor ist für die Verwendung mit erwachsenen Hühnern vorgesehen. Deaktivieren Sie das Produkt, wenn sich Hühner im Alter von unter 15 Wochen im Hühnerhaus befinden.
- Sehen Sie jeden Morgen nach Ihren Hühnern, um sicherzugehen, dass sie Zugang zu Futter und Wasser haben.
- Verlassen Sie sich nicht ausschließlich auf dieses Produkt, um Ihre Hühner zu betreuen.
- Halten Sie Ihre Finger von der sich bewegenden Tür fern.
- Stellen Sie sicher, dass überschüssiges Kabel sicher verstaut ist, um Stolpern oder versehentliches daran Ziehen zu vermeiden.
- Vergewissern Sie sich, dass das Bedienfeld vollständig montiert ist, bevor Sie den Strom einschalten.
- Nehmen Sie das Bedienfeld nicht auseinander, wenn es nass ist.
- Vergewissern Sie sich, dass das Produkt sicher befestigt ist, bevor es in Betrieb genommen wird.
- Kinder müssen bei der Verwendung der Automatischen Hühnerstalltür beaufsichtigt werden - sie ist kein Spielzeug.
- Jede andere als die angegebene Verwendung gilt als nicht bestimmungsgemäß. Jegliche direkte gewerbliche oder industrielle Nutzung gilt ebenfalls als nicht bestimmungsgemäß. Omlet haftet nicht für Schäden, die sich aus einer solchen Verwendung ergeben. Das Risiko trägt allein der Benutzer.

FR Information importante ! À lire avant utilisation

- La porte automatique Omlet est un équipement de sécurité automatisé conçu pour permettre ou interdire l'accès au poulailler. Cet accessoire ne vous aidera pas à prendre soin de vos poules à proprement parler : vous devrez toujours effectuer vos contrôles de routine quotidiens pour vérifier que vos poules sont en bonne santé et en sécurité et qu'elles ont de l'eau et de la nourriture à disposition.
- Veuillez consulter le manuel fourni avant d'utiliser ce produit.
- Suivez attentivement la notice d'installation pour vous assurer que la Porte Automatique Omlet fonctionne normalement.
- Ce produit ne doit être utilisé que pour l'usage pour lequel il est a été conçu.
- Vos poules risquent de rester coincées dans ce produit. Veuillez enlever tout objet ou toute saleté afin que le détecteur de collision puisse fonctionner correctement.
- La porte automatique a été conçue pour être utilisée par des poules adultes. Veuillez désactiver le produit si vous gardez des poules âgées de moins de 15 semaines dans votre poulailler.
- Assurez-vous que vos poules disposent d'assez d'eau et de nourriture tous les matins.
- Ne comptez pas que sur ce produit pour vous occuper de vos poules.
- N'insérez pas vos doigts dans la porte quand elle s'ouvre ou se ferme.
- Veillez à ce que le câble soit rangé correctement pour éviter qu'il ne soit tiré ou ne fasse tomber quelqu'un par accident.
- Assurez-vous que le tableau de bord soit correctement assemblé avant de l'allumer.
- Ne démontez pas le tableau de bord s'il a été mouillé.
- Assurez-vous que le produit ait été attaché fermement avant de l'utiliser.
- Les enfants utilisant la Porte Automatique Omlet doivent être supervisés par des adultes (ce n'est pas un jouet).
- Tout usage de la Porte Automatique Omlet au-delà de ceux pour lesquels elle est conçue doit être considéré comme inadéquat. Tout usage commercial ou industriel sera également jugé incorrect. Omlet n'est en aucun cas responsable des éventuels problèmes résultant de telles utilisations. L'utilisateur en assumera pleinement les conséquences.

NL Belangrijke informatie! Lees a.u.b. aandachtig voor gebruik

- Omlets Autodoor is uitsluitend ontworpen om de toegang tot een kippenhok automatisch te openen en sluiten. Het is geen apparaat dat voor uw kippen zorgt. Als eigenaar dient u nog steeds de dagelijkse routinecontroles uit te voeren, zoals het controleren of uw dieren toegang hebben tot voer en water, om de gezondheid en veiligheid van uw kippen te garanderen.
- Lees voor gebruik van dit product de bijgevoegde gebruiksaanwijzing.
- Volg de gebruiksaanwijzing om ervoor te zorgen dat het product naar behoren functioneert.
- Gebruik dit product uitsluitend waarvoor het is bestemd.
- Uw kippen kunnen bekneld raken. Houd het product vrij van vuil en obstructies om een correcte werking van de beknellingsdetector te waarborgen.
- De Autodoor is ontworpen voor gebruik met volwassen kippen. Schakel het product uit als u kippen jonger dan 15 weken in het kippenhok houdt.
- Controleer uw kippen elke morgen om er zeker van te zijn dat ze toegang hebben tot voer en water.
- Vertrouw voor de verzorging van uw kippen niet uitsluitend op dit product.
- Houd uw vingers uit de buurt van de deur wanneer deze sluit
- Verberg het overtollige deel van de kabel om te voorkomen dat u erover struikelt of er per ongeluk aan trekt.
- Zorg ervoor dat het bedieningspaneel volledig is geïnstalleerd voordat u de stroom inschakelt.
- Demonteer het bedieningspaneel niet wanneer deze nat is.
- Zorg ervoor dat het product goed is bevestigd voordat u het in gebruik neemt.
- Houd toezicht op kinderen als zij gebruik maken van de Autodoor - het is geen speelgoed.
- Elk ander gebruik dan aangegeven wordt beschouwd als onjuist gebruik. Ook rechtstreeks commercieel en industrieel gebruik wordt beschouwd als onjuist. Omlet kan niet aansprakelijk worden gesteld voor schade veroorzaakt door dergelijk gebruik. Alleen de gebruiker is hiervoor verantwoordelijk.

IT Informazioni importanti! Leggere prima dell'utilizzo

- L'Auto Porta di Omlet è un sistema di apertura automatico e sicuro che permette alle vostre galline di entrare e uscire comodamente dal pollaio. Questo non è un prodotto che si prende cura dei vostri animali. L'Auto Porta rappresenta un aiuto, dovrete comunque occuparvi delle vostre galline effettuando i vari controlli giornalieri per assicurarvi che siano in salute e abbiano sempre accesso a cibo e acqua.
- Leggere il manuale di istruzioni fornito prima di utilizzare il prodotto.
- Seguire attentamente le istruzioni di assemblaggio in modo da essere sicuri che l'Auto Porta funzioni correttamente come da manuale.
- Il prodotto va utilizzato solo per le finalità previste.
- C'è il pericolo che le galline restino intrappolate per cui mantenete il prodotto libero da sporcizia e ostruzioni in modo da assicurare il corretto funzionamento del rilevatore di schiacciamento.
- La porta automatica è progettata per essere utilizzata da galline adulte. Disabilitate il prodotto se avete delle galline al di sotto delle 15 settimane di età.
- Controllate tutte le mattine le galline per assicurarvi che abbiano accesso a cibo e acqua.
- Non affidatevi solo a questo prodotto per prendervi cura della galline.
- Tenete le dita lontano dalla porta quando è in movimento.
- Assicuratevi che i cavi siano in ordine in modo da essere certi di non tirarli per sbaglio o inciamparci.
- Assicuratevi che il pannello di controllo sia completamente assemblato prima di farlo partire.
- Non smontate il pannello di controllo se è umido.
- Assicuratevi che il prodotto sia correttamente attaccato prima di renderlo operativo.
- L'Auto Porta non è un giocattolo: i bambini devono essere supervisionati da un adulto quando usano il prodotto.
- Ogni uso dell'Auto Porta diverso da quello raccomandato è da considerarsi improprio, così come qualsiasi diretto uso commerciale o industriale. Omlet non è responsabile per danni causati dall'uso dell'Auto Porta. L'acquirente è da considerarsi il solo responsabile.

SE Viktig information! Läs innan du använder

- Omlets automatiska dörr är designad för att användas endast som ett sätt att automatiskt öppna och stänga dörren till ditt höns hus. Det är inte en produkt som tar hand om dina höns. Som ägare måste du fortfarande genomföra alla dagliga rutiner för att se till att dina höns håller sig friska och säkra, t.ex. se till att de har tillgång till mat och vatten.
- Du måste läsa den medföljande bruksanvisningen innan du använder den här produkten.
- Du måste följa instruktionsmanualen för att se till att produkten fungerar som den ska.
- Produkten skall endast användas för avsett ändamål.
- Det är viktigt att produkten hålls fri från smuts och andra blockeringar för att säkerhetssensorn ska fungera, det finns annars en risk att dina höns fastnar.
- Den automatiska dörren har designats för att användas med vuxna höns. Koppla ifrån den om det finns höns som är yngre än 15 veckor i höns huset.
- Titta till dina höns varje morgon för att se till att de har tillgång till mat och vatten.
- Förlita dig inte enbart på den här produkten för att ta hand om dina höns.
- Håll fingrarna borta från dörren när den är i rörelse.
- Om inte hela kabellängden behövs, se till att den extra längden göms undan för att undvika att någon ramlar eller fastnar och drar i kabeln.
- Se till att kontrollpanelen är monterad enligt instruktionerna innan du kopplar den till en strömkälla.
- Ta inte av kontrollpanelen när den är blöt.
- Se till att produkten har monterats enligt anvisningarna innan den används.
- Barn måste övervakas när de använder autodörren - den är inte en leksak.
- All användning utöver vad som är menat bör ses som olämplig användning. All direkt kommersiell eller industriell användning anses också olämplig. Omlet tar inget ansvar för skador orsakade av denna sorts användning, utan ägaren står för potentiella risker.

- Omlets automatiske dør er udelukkende designet til at bruge som en automatiseret måde at åbne og lukke døren på et høsehus. Enheden kan ikke passe dine høns. Som høseejer skal du stadig udføre alle de rutinemæssige daglige opgaver for at sikre dine høns' sundhed og sikkerhed såsom at sørge for, at dine høns har adgang til foder og vand.
- Læs venligst medfølgende brugsanvisning inden du anvender dette produkt.
- Du skal følge brugsanvisningen for at sikre, at produktet fungerer som det skal.
- Produktet må kun bruges til det tilsigtede formål.
- Hold produktet fri for snavs og andre forhindringer for at sikre, at sikkerhedssensoren fungerer korrekt, da der ellers vil være fare for, at dine høns kan blive fanget.
- Den automatiske dør til høsehuset er designet til brug med voksne høns. Deaktiver produktet, hvis der er kyllinger på under 15 uger i høsehuset.
- Se til dine høns hver morgen for at sikre, at de har adgang til foder og vand.
- Stol ikke udelukkende på dette produkt til pasning af dine høns.
- Hold fingrene væk fra døren, når den er i bevægelse.
- Sørg for at overskydende ledning pakkes væk for at undgå at komme til at snuble over eller trække i den.
- Sørg for at kontrolpanelet er fuldstændigt samlet, inden du tænder for strømmen.
- Skil ikke kontrolpanelet ad mens det er vådt.
- Sørg for at produktet er sikkert fastgjort, før det betjenes.
- Børn skal være under opsyn ved brug af den automatiske dør - det er ikke et legetøj.
- Enhver anden anvendelse end den, der er angivet, betragtes som ukorrekt anvendelse. Enhver direkte kommerciel eller industriel anvendelse anses også for ukorrekt. Omlet er ikke ansvarlig for nogen skade som følge af ukorrekt anvendelse. Brugeren alene bærer risikoen.

EN Table of Contents

- 09 What you have received
- 10 Exploded diagrams of Auto Door & Control Panel
- 11 What you will need
- 48 Assembly
- 48 Quickstart Guide
- 49 Calibration
- 49 Change Language
- 50 How do you want to use the Auto Door?
- 50 Manual Mode
- 51 Time Mode
- 53 Light Mode
- 103 Emergency Fail Safe
- 106 Cleaning
- 121 Testing the Crush Detector

DE Inhaltsverzeichnis

- 09 Das haben Sie erhalten
- 10 Explosionszeichnung der Automatischen Tür und des Steuerelements
- 11 Das benötigen Sie
- 48 Montage
- 48 Schnellstart-Anleitung
- 55 Kalibrierung
- 55 Sprache ändern
- 56 Wie wollen Sie die Automatische Tür verwenden?
- 56 Manueller Modus
- 57 Zeitmodus
- 59 Lichtmodus
- 103 Öffnung bei Fehlfunktion
- 106 Reinigung
- 121 Den Sicherheitssensor testen

FR Sommaire

- 09 Ce qui est fourni
- 10 Vue éclatée de la Porte Automatique Omlet et du tableau de bord
- 11 Ce dont vous aurez besoin
- 48 Montage
- 48 Bien démarrer avec la Porte Automatique Omlet
- 61 Calibrage
- 61 Changer la langue
- 62 Comment utiliser la Porte Automatique Omlet ?
- 62 Mode manuel
- 63 Mode horaire
- 64 Mode luminosité
- 103 En cas de dysfonctionnement
- 106 Nettoyage
- 121 Test du détecteur d'obstacles

NL Inhoudsopgave

- 09 Wat u heeft ontvangen
- 10 Gedemonteerde doorsneden van de automatische deur en bedieningspaneel
- 11 Wat u nodig heeft
- 48 Montage
- 48 Snelstart handleiding
- 67 Afstellen
- 67 Taal wijzigen
- 68 Hoe wenst u de automatische deur te gebruiken?
- 68 Manual-mode
- 69 Time-mode
- 71 Daglicht-mode
- 103 Noodmodus bij falen
- 106 Reinigen
- 121 Het testen van de knel-detector

IT Sommario

- 09 Cosa avete ricevuto
- 10 Diagramma esploso dell'Auto Porta e del Pannello di Controllo
- 11 Avete anche bisogno di
- 48 Montaggio
- 48 Guida Rapida
- 73 Calibrazione
- 73 Cambio lingua
- 74 Come volete utilizzare l'Auto Porta?
- 74 Modalità Manuale
- 75 Modalità Tempo
- 77 Modalità Luce
- 103 Sistema di Apertura di Emergenza
- 106 Pulizia
- 121 Testare il Sistema a Fotocellula

SE Innehållsförteckning

- 09 Vad du har fått
- 10 Exploderade diagram av autodörren och kontrollpanelen
- 11 Vad du behöver
 - Montering
- 48 Snabbguide
- 79 Kalibrering
- 79 Ändra språk
- 80 Hur vill du använda autodörren?
- 80 Manuell inställning
- 81 Tidsinställning
- 63 Ljusinställning
- 103 Öppna dörren i nödläge
- 106 Rengöring
- 121 Testa krossdetektorn

DK Indholdsfortegnelse

- 09 Hvad du har modtaget
- 10 Eksploderede diagrammer af den automa-tiske dør og kontrolpanelet
- 11 Hvad du skal bruge
 - Montering
- 48 Hurtig startvejledning
- 65 Kalibrering
- 65 Skift sprog
- 86 Hvordan vil du gerne bruge den automa-tiske dør?
- 86 Manuel funktion
- 87 Tidsindstillet funktion
- 89 Lyssensor funktion
- 103 Åbning af døren i nødstilfælde
- 106 Rengøring
- 121 Afprøvning af sikkerhedssensoren

What you have received

DE Das haben Sie erhalten · FR Ce qui est fourni · NL Wat u heeft ontvangen · IT Cosa avete ricevuto
SE Vad du har fått · DK Hvad du har modtaget

107.0018: Boxed Autodoor



X1
Automatic Door Frame
014.0026

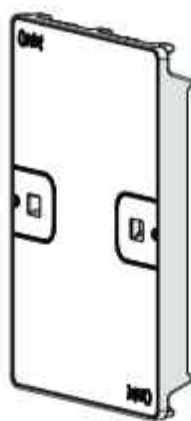

X1
Door
014.0027



X1
Control Panel
107.0014



X2
Retaining Bracket
014.1152

014.0042: Fixings Pack

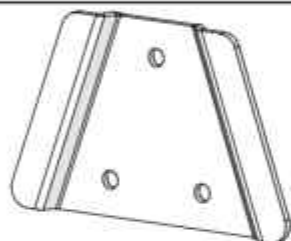

X1
Mounting Plate
014.1135



X2
Mounting
Bracket
014.1167



X4
Bracket
Threaded
064.1016



X4
Winged Nut
800.0040



X4
Machine Screw
M6x40mm
800.0179



X4
Machine Screw
M6x70mm
800.0257



X6
Cable Tie
800.0103



X3
Wood Screw
3.5x12mm
800.0096



X16
Self Tapping Screw
3.5x20mm
800.0061

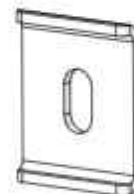

X4
Run Handle
Washer
810.0245



X2
Machine Screw
6x10mm
800.0240

014.0043: Autodoor Fixings Gear



X1
Autodoor
Metal Gear
014.1177



X1
Autodoor
Gear Stay
014.1140



X4
Retaining
Bracket
Machine
Screw
800.0007

Plans to buy a new Eglu? Hold on to spare fixings.



- DE Wenn du vorhast, in Zukunft einen neuen Eglu zu kaufen, bewahre alle Ersatzbefestigungen sicher auf
- FR Si vous envisagez d'acheter un nouveau poulailler Eglu à l'avenir, conservez les fixations de rechange.
- NL Als je van plan bent om in de toekomst nog een Eglu te kopen, bewaar de reserveonderdelen dan op een veilige plek.
- IT Se in futuro intendete acquistare un nuovo Eglu, conservate i pezzi di ricambio
- SE Om du planerar att köpa en ny Eglu i framtiden, förvara eventuella extra fästen säkert
- DK Hvis du planlægger at købe en ny Eglu i fremtiden, skal du opbevare eventuelle ekstra fastgørelser sikkert

Exploded Diagrams of the Automatic Door and Control Panel

DE Explosionszeichnung der Automatischen Tür und des Steuerungskastens · FR Vues éclatées de la Porte Automatique Omlet et du tableau de bord · NL Explosietekening van de automatische deur en het bedieningspaneel
 IT Diagrammi esplosi dell'Auto Porta e del Pannello di Controllo · SE Exploderade diagram av autodörren och kontrollpanelen · DK Diagram der viser den automatiske dør og kontrolpanelet

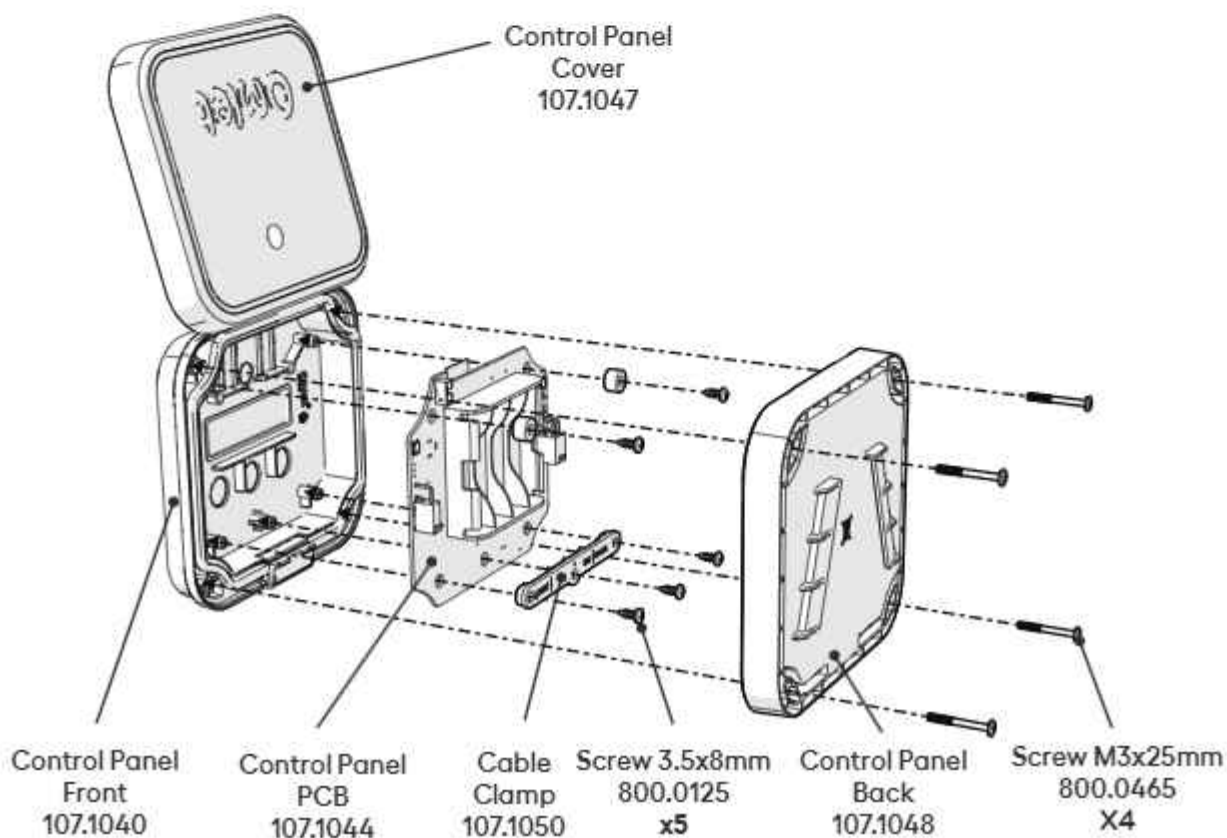
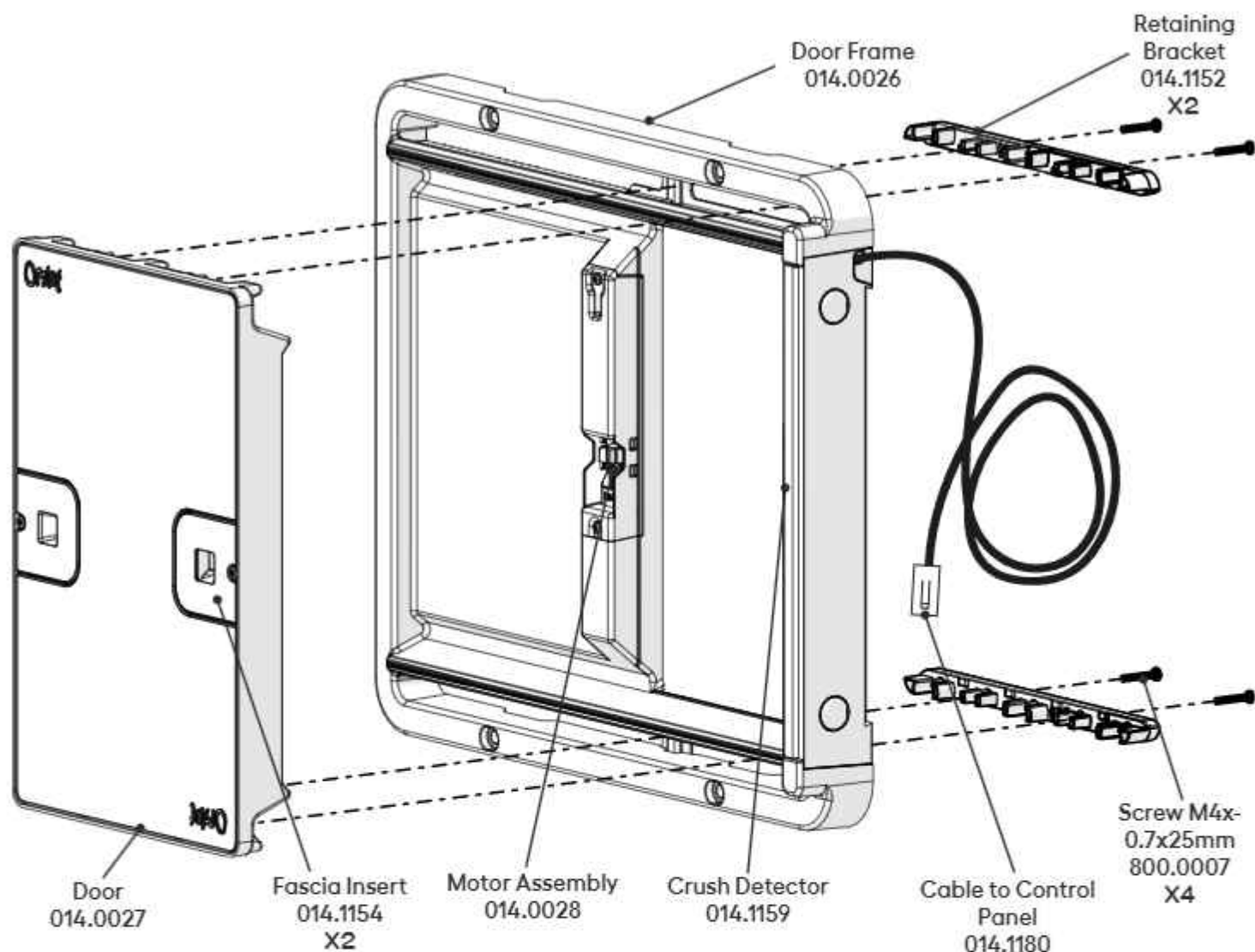

You will need...

DE Das brauchen Sie... - FR Vous aurez besoin de... - NL Wat u nodig heeft... - IT Avrai bisogno... - SE Du behöver...
DK Du skal bruge...



AA Battery 1.5V
X4

Do not use a Power Drill to tighten screws



- DE Verwenden Sie zum Anziehen der Schrauben keinen Schnellbauschrauber
- FR N'utilisez pas une perceuse pour serrer les vis
- NL Gebruik voor het aandraaien van schroeven nooit een boormachine
- IT Non utilizzare un trapano per stringere le viti
- SE Använd inte en elektrisk bormaskin för att dra åt skruvarna
- DK Anvend ikke boremaskine til at stramme skruerne

If connecting to Wi-Fi, then scan a QR below to download the Omlet App.

DE Wenn Sie eine WLAN-Verbindung herstellen wollen, scannen Sie einen der nachstehenden QR-Codes, um die Omlet-App herunterzuladen.

FR Si vous vous connectez au Wi-Fi, scannez le QR code ci-dessous pour télécharger l'application Omlet.

NL Als u verbinding maakt met Wi-Fi, scan dan hieronder een QR-code om de Omlet-app te downloaden.

IT Se ti connetti al Wi-Fi, scansiona il codice QR qui sotto per scaricare l'app Omlet.

SE Om du kopplar till wifi, scanna QR koden nedan eller ladda ner Omlet-appen.

DK Hvis du opretter forbindelse til Wi-Fi, skal du scanne en QR-kode nedenfor for at downloade Omlet-appen.



← For Apple



← For Android

1

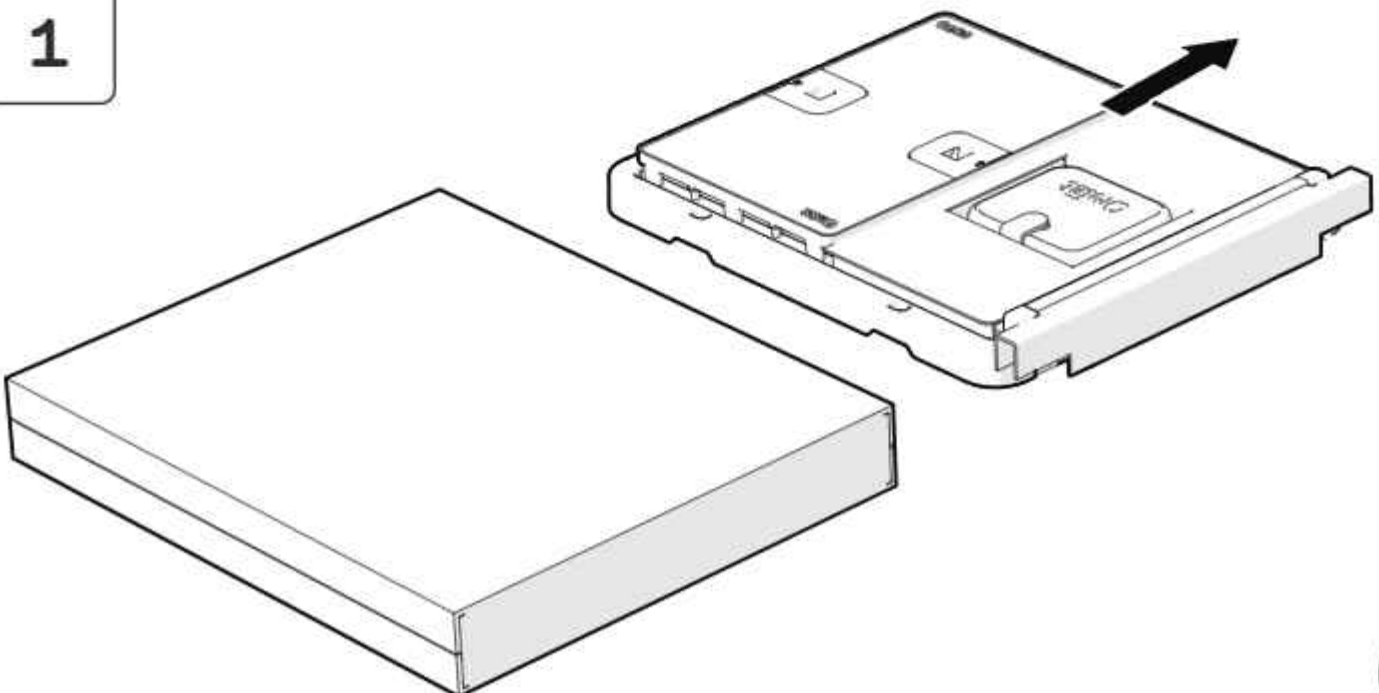

2

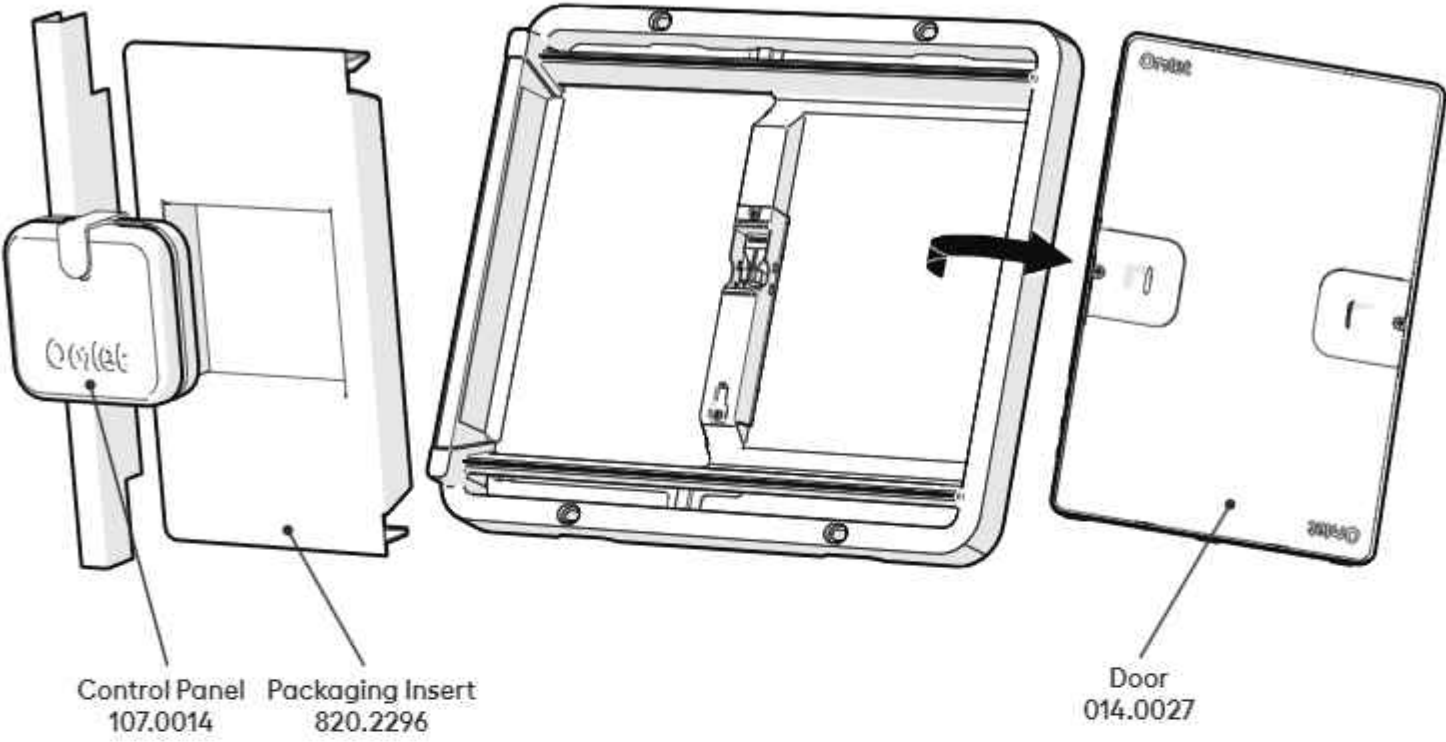

3

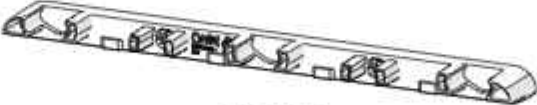
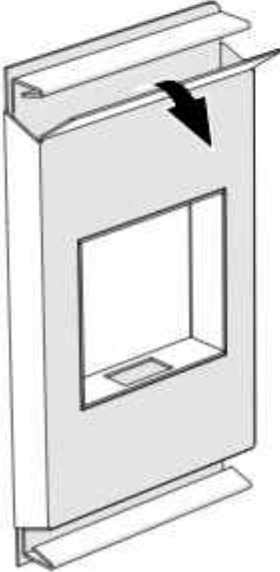

014.1152
X2

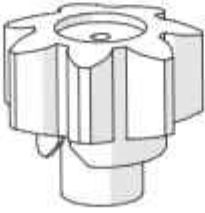

014.1177
X1



014.1140
X1



800.0007
X4

4

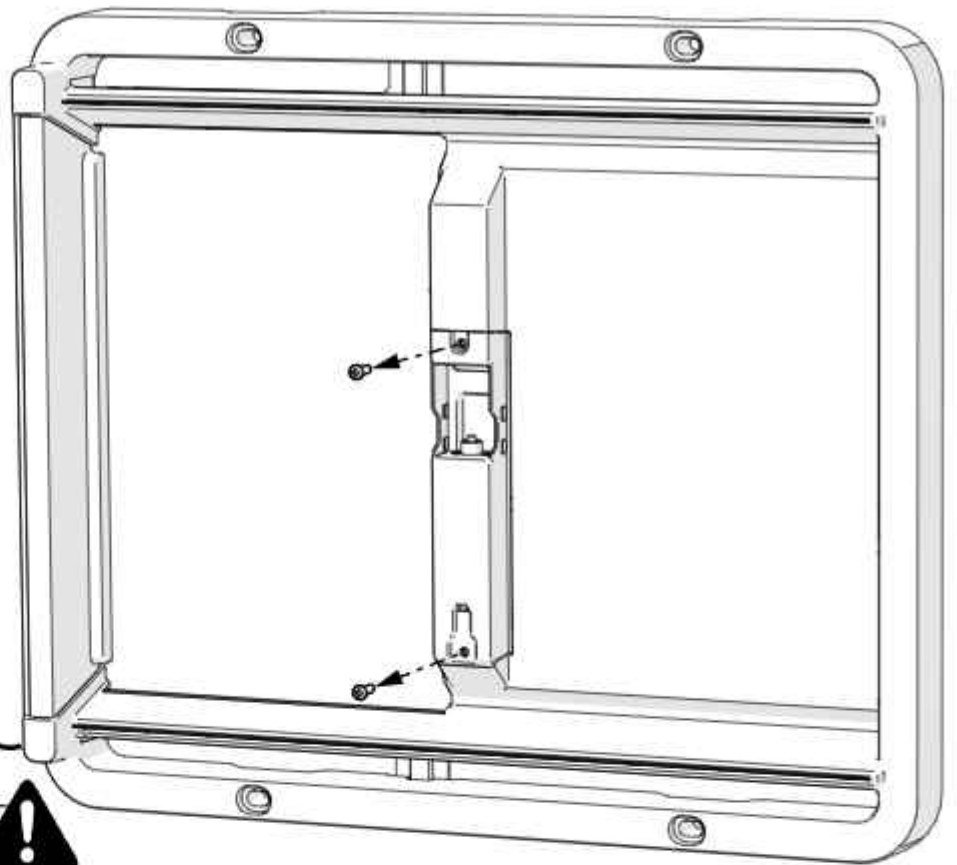

Keep the Parts safe until Step 8



- DE Bis Schritt 8 sicher aufbewahren
- FR Mettez ces pièce de côté pour l'étape 8
- NL Leg de onderdelen opzij tot stap 8
- IT Mettere da parte fino al Punto 8
- SE Lågg undan delarna till steg 8
- DK Læg delene til side indtil trin 8

5

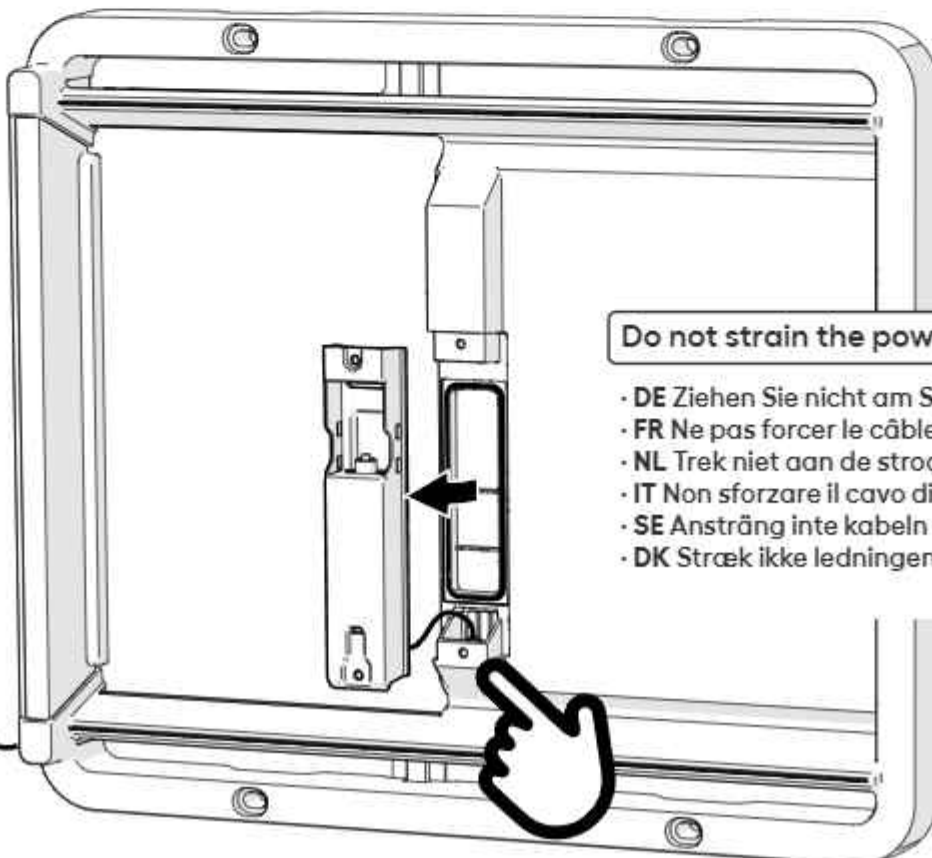

Do not strain the power cable



- DE Ziehen Sie nicht am Stromkabel
- FR Ne pas forcer le câble d'alimentation
- NL Trek niet aan de stroomkabel
- IT Non sforzare il cavo di alimentazione
- SE Ansträng inte kabeln genom att sträcka den
- DK Stræk ikke ledningen

6

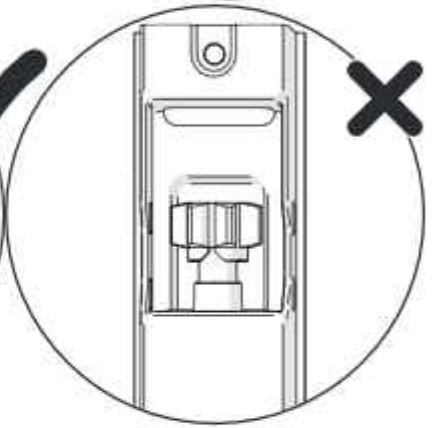
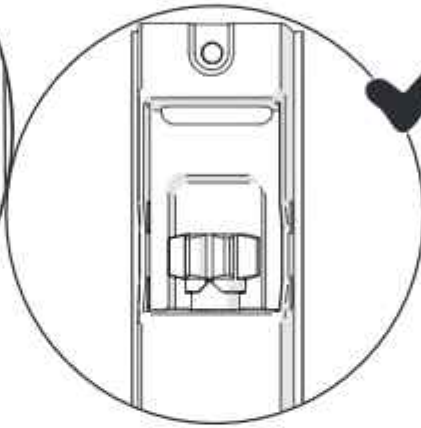
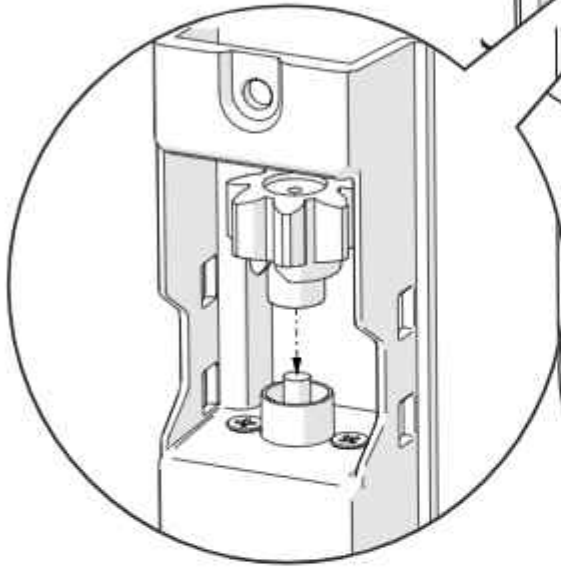
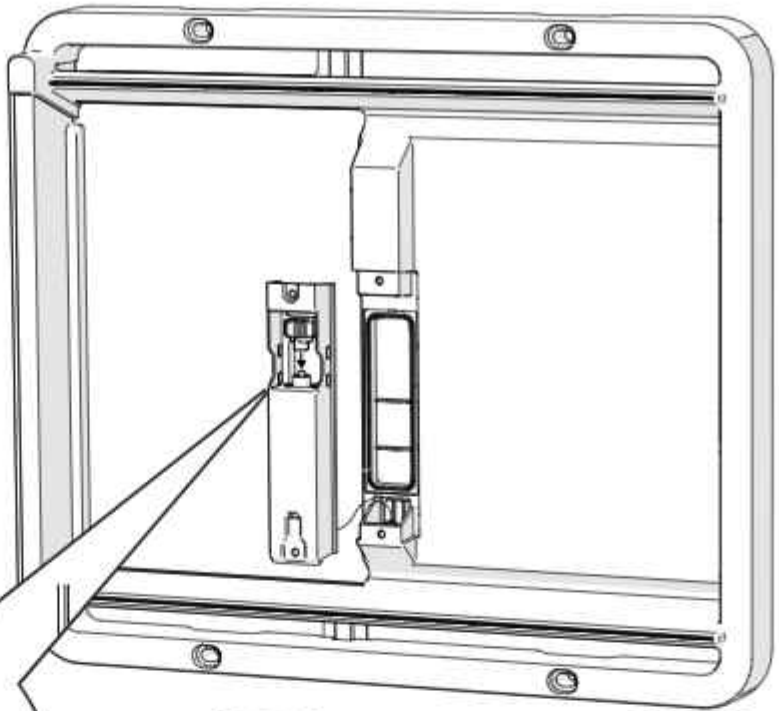

7

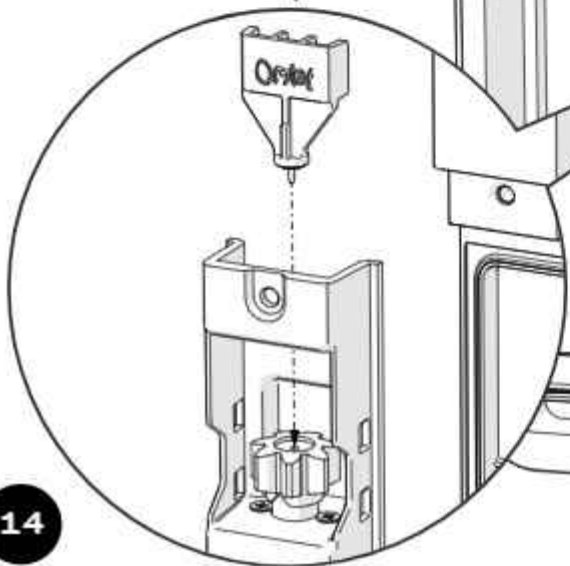
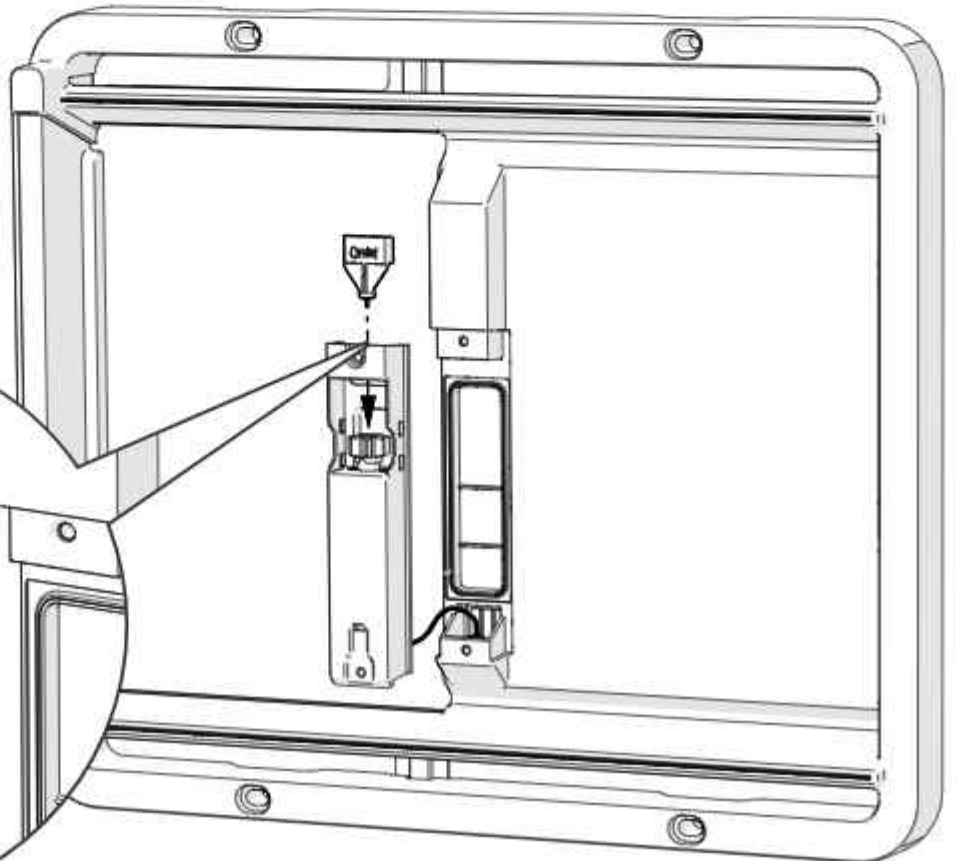

8**Ensure the power cable does not get trapped**

- DE Stellen Sie sicher, dass das Stromkabel nicht eingeklemmt wird
- FR Assurez-vous que le câble d'alimentation ne soit pas coincé
- NL Zorg ervoor dat de stroomkabel niet klem komt te zitten
- IT Assicurarsi che il cavo di alimentazione non rimanga intrappolato
- SE Se till att kabeln inte fastnar
- DK Sørg for at ledningen ikke kommer i klemme

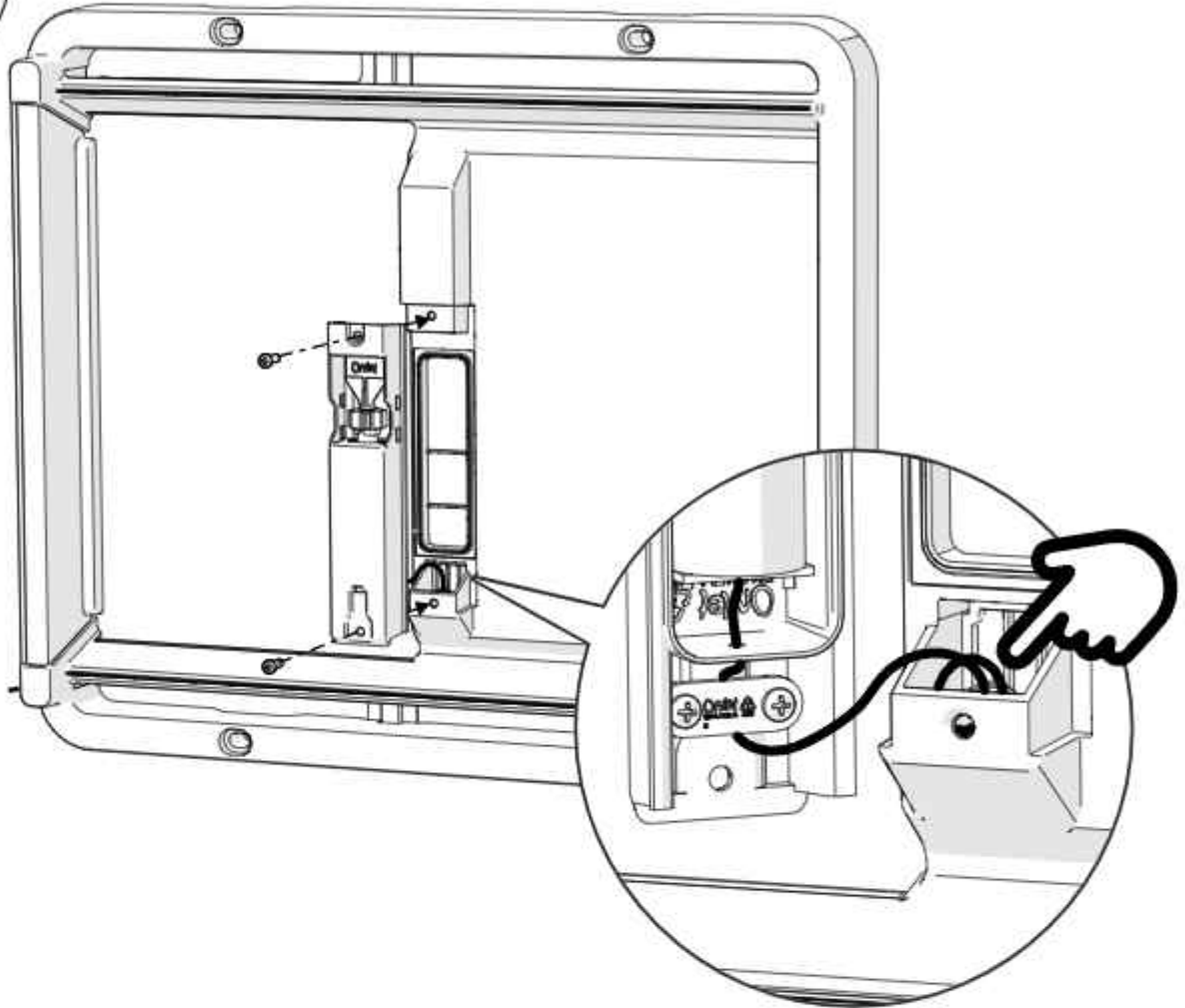
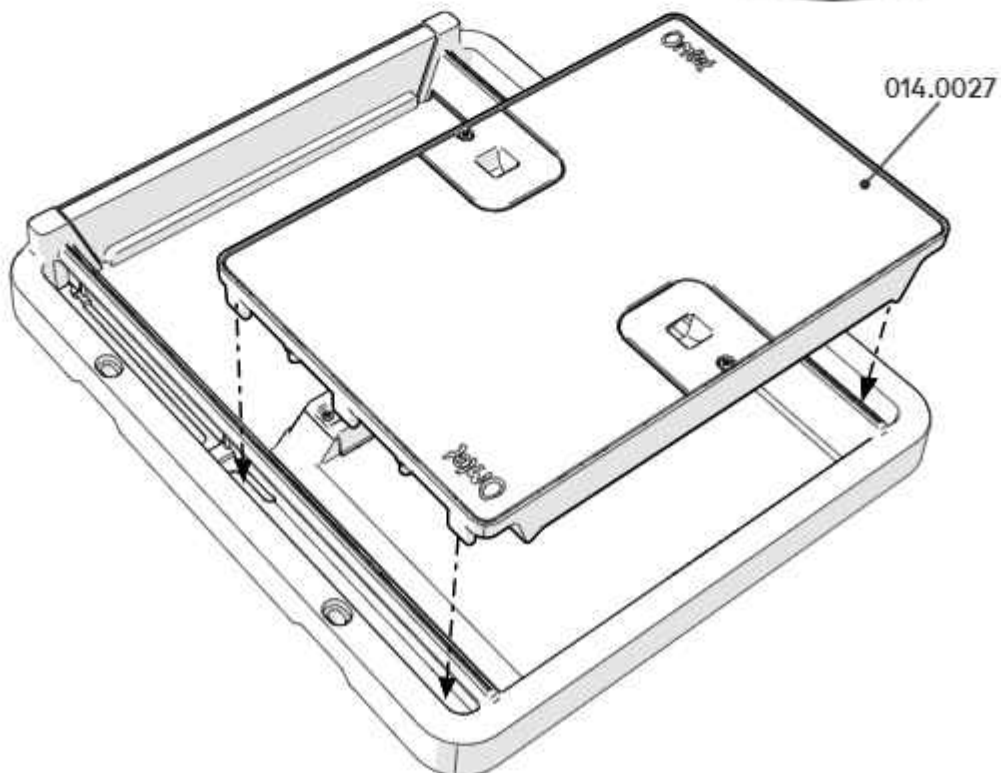
**9**

10



X4
800.0007

014.1152
X2

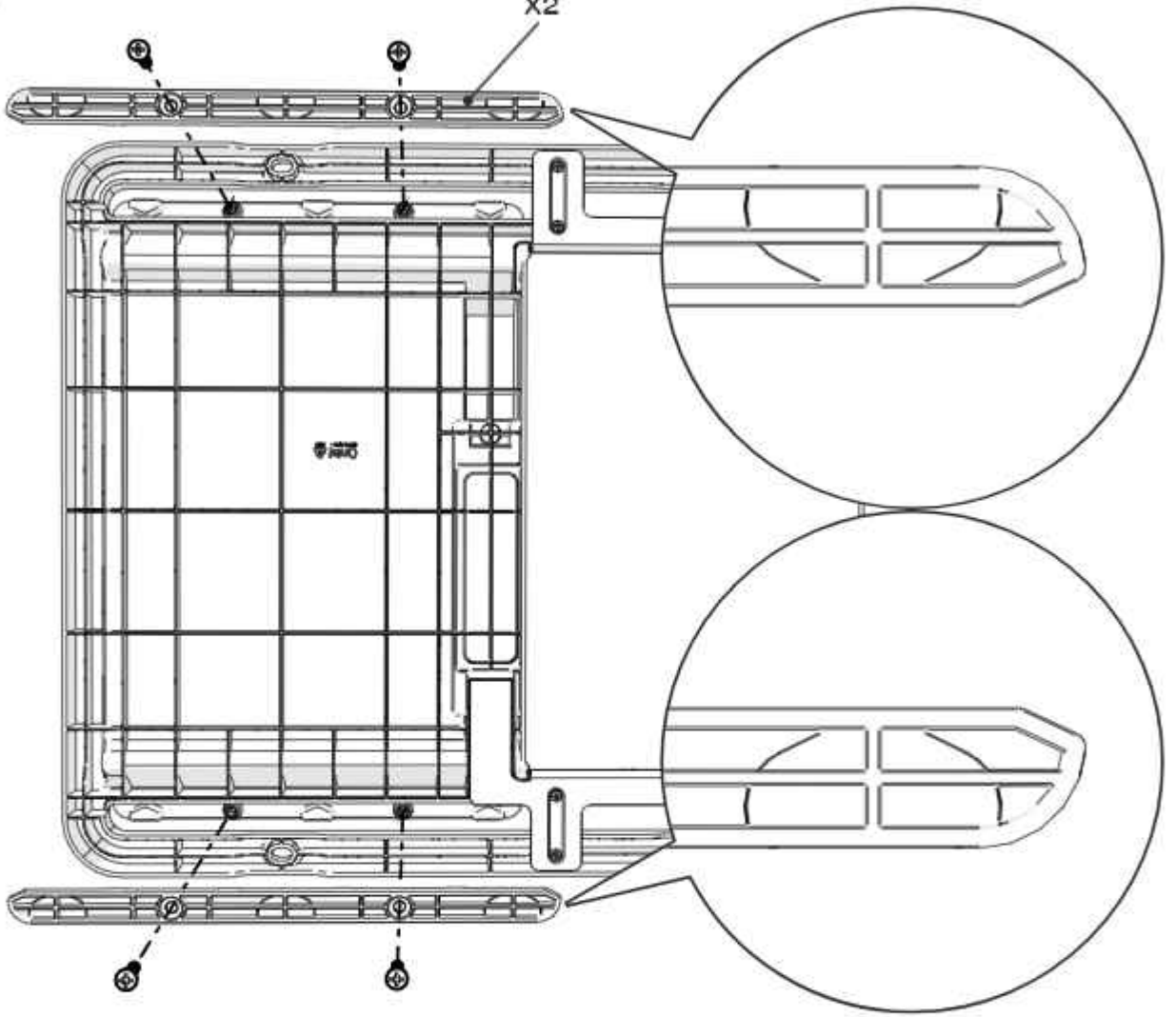

Optional Attachment Kits - sold separately

DE Optionale Anbausätze - separat erhältlich - FR Kits de fixation facultatives - vendues séparément

NL Optionele opzetkits - worden afzonderlijk verkocht - IT Kit di attacco opzionali - venduti separatamente

SE Extra tillbehörssatser - säljs separat - DK Valgfri monteringsbeslag - sælges separat

014.0056: Control Panel Mounting Bracket Cube Mk2 & Pro House



X1

Control Panel Mounting Bracket
Cube Mk2 & Pro House
014.0056

014.0058: Eglu Cube Mk1 House Control Panel Mounting Bracket



X1

Eglu Cube Mk1
Control Panel Mounting Bracket
014.0057



X1

Machine Screw
M6x10mm
800.0240

014.0068: Eglu Cube Mk1 Mounting Kit



X1

Eglu Cube Mk1
Auto Door Bottom
Mounting Bracket
014.0066



X1

Eglu Cube Mk1
Auto Door Door Infill
014.1192



X1

Eglu Cube Mk1
Auto Door Top
Mounting Bracket
014.1191

014.0069: Eglu Cube Mk1 Auto Door Mounting Bracket Fixings Pack



X4

Machine Screw M6x30mm
800.0247

810.0074 Mesh Edge Protector Kit



X2

Mesh Edge
Protector 215mm
810.1064



X2

Mesh Edge
Protector 300mm
810.1065

014.0072: Wooden Coop Mesh Autodoor Mounting Kit



X2

Wood Frame Vertical Batten
014.1183



X2

Wood Frame Horizontal Batten
014.1182

014.0043: Autodoor Wooden Coop Fixings Pack



X8

Wood Screw 4mmx40mm
800.0291

Optional Accessories

DE Extra Zubehör - FR Accessoires en option - NL Optionele accessoires - IT Accessori opzionali - SE Valbara tillbehör
DK Valgfrit tilbehør



X1

Omlet Coop
Light
014.0062



X1

AD Replacement
Wire
014.0080



X1

12V Power
Adaptor UK
810.0359



X1

12V Power
Adaptor EU
810.0360



X1

12V Power
Adaptor USA
810.0361



X1

12V Power
Adaptor AUS
810.0362

How to attach your Auto Door to your Eglu or chicken run

- DE Wie die Autodoor am Eglu oder Hühnergehege befestigt wird
- FR Comment fixer votre Porte Automatique à votre enclos ou poulailler Eglu
- NL Hoe bevestig je de Autodoor aan je Eglu of kippenren
- IT Come collegare la Porta Automatica al vostro recinto o pollaio Eglu
- SE Hur Autodörren monteras på Eglu höns hus eller höns gård
- DK Sådan fastgør du din AutoDoor til din Eglu eller høns gård

Eglu Cube Mk2 House



→ 11

Eglu Pro House

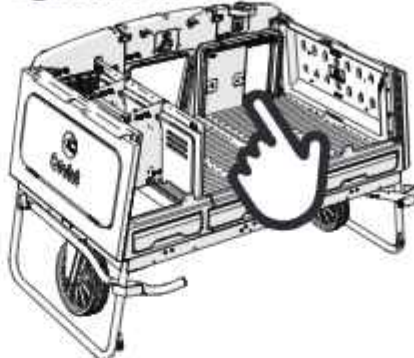

→ 25

Omlet Mesh:

Walk in Run
Eglu Cube Mk1 & Mk2,
Eglu Pro
Eglu Go,
Eglu Go UP,
Eglu Classic

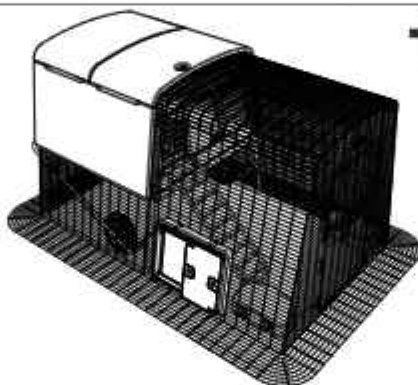

+ 810.0074: Mesh Edge Protector Kit

→ 37

Wood



→ 41

Non-Omlet Mesh



→ 45

+ 014.0072: Autodoor Wooden Coop Mesh Mounting Kit

If you would like to connect your autodoor to a classic run or Eglu Cube MK1, please visit:
www.omlet.co.uk/instructions



- DE Um die Autodoor an einem Eglu Classic Auslauf oder Eglu Cube mk1 zu befestigen, besuche bitte: www.omlet.de/anleitungen
- FR Si vous souhaitez installer votre Porte Automatique sur un enclos classique ou un poulailler Eglu Cube Mk1, veuillez consulter la page suivante: www.omlet.fr/instructions
- NL Als je de Autodoor wilt bevestigen aan een klassieke ren of de Eglu Cube mk1, bekijk dan: www.omlet.nl/gebruiksaanwijzing
- IT Se desiderate collegare Autodoor a un recinto classico o Eglu Cube mk1, visitate la pagina: www.omlet.it/istruzioni
- SE Om du vill montera din Autodörr på en klassisk höns gård eller Eglu Cube Mk1, besök: www.omlet.se/bruksanvisning
- DK Hvis du ønsker at tilslutte din Autodoor til en klassisk løbegård eller Eglu Cube mk1, kan du læse mere her: www.omlet.dk/brugsanvisning

Attach the door to Eglu Cube Mk2

DE Die Tür am Eglu Cube anbringen · FR Fixation de la porte à l'Eglu Cube · NL De deur bevestigen op Eglu Cube Mk2
IT Attaccare la Porta all'Eglu Cube · SE Montera dörren på en Eglu Cube · DK Montering af døren på Eglu Cube

11

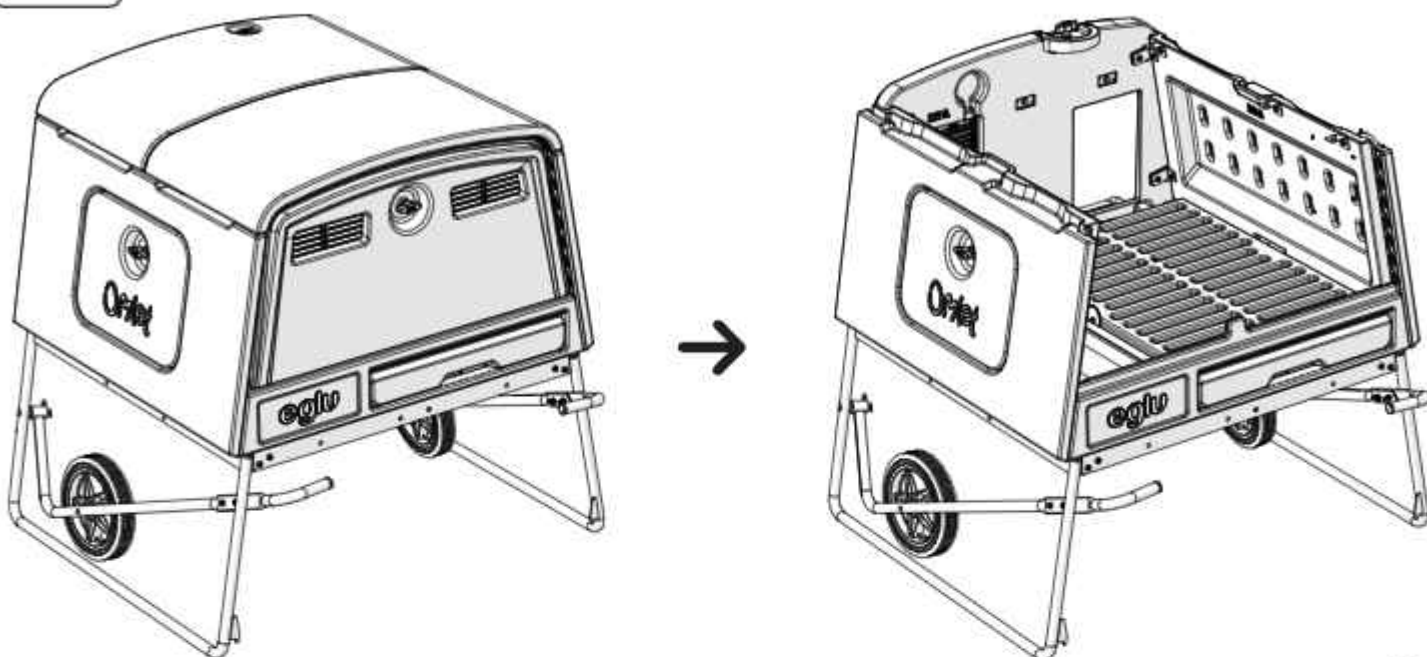

Roof removal optional



DE Die Entfernung des Daches ist optional · FR Le retrait du toit est facultatif
NL Verwijderen van het dak is optioneel · IT La rimozione del tetto è facoltativa · SE Takavlägsnande är valfritt
DK Fjernelse af taget er valgfrit

12

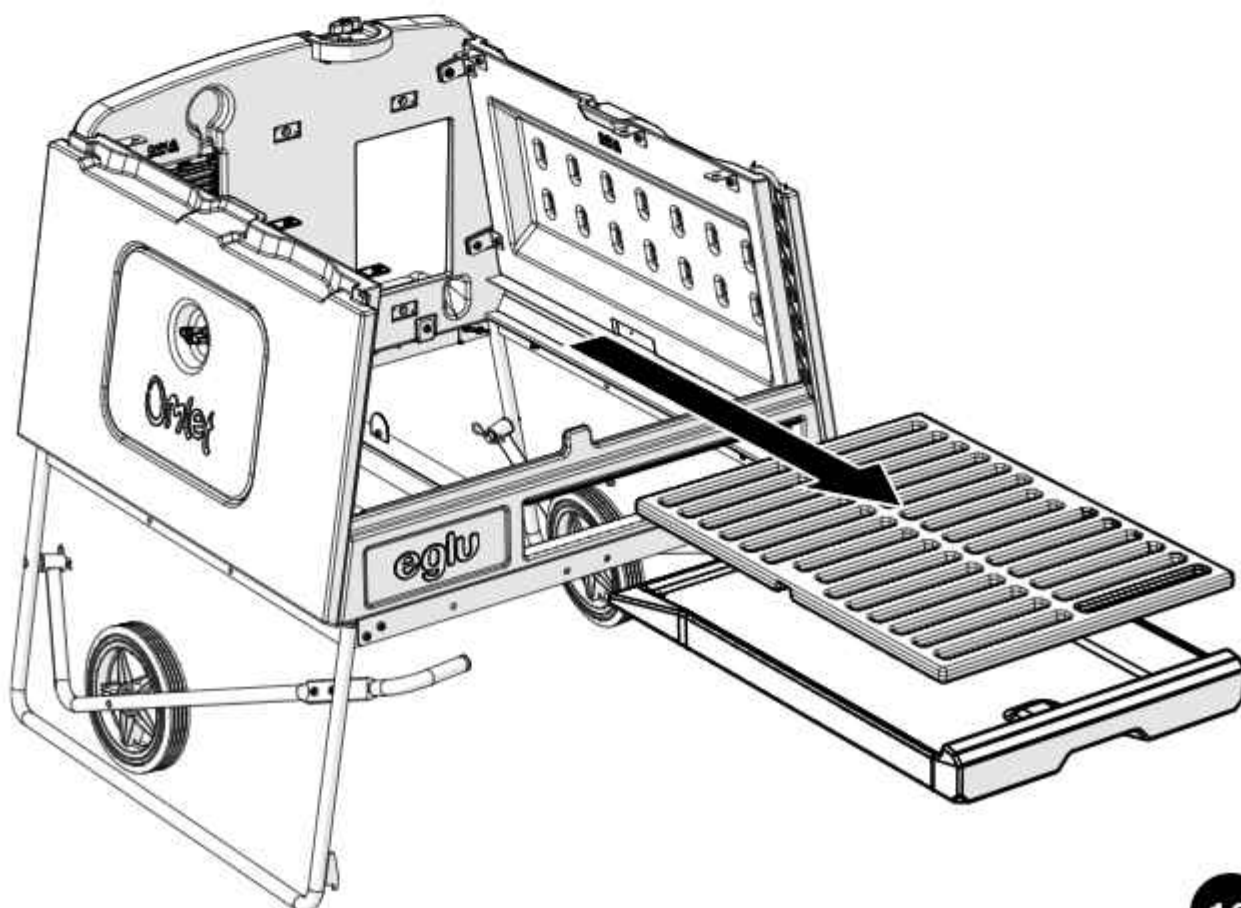

13

Keep the Parts safe until Step 14



- DE Legen Sie die Teile bis Schritt 14 beiseite
- FR Mettez ces pièces de côté pour l'étape 14
- NL Leg de onderdelen opzij tot stap 14
- IT Mettere da parte fino al Punto 14
- SE Lägg undan delarna till Steg 14
- DK Læg delene til side indtil trin 14

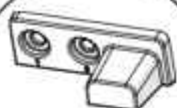

X1
064.1143



X1
800.0240

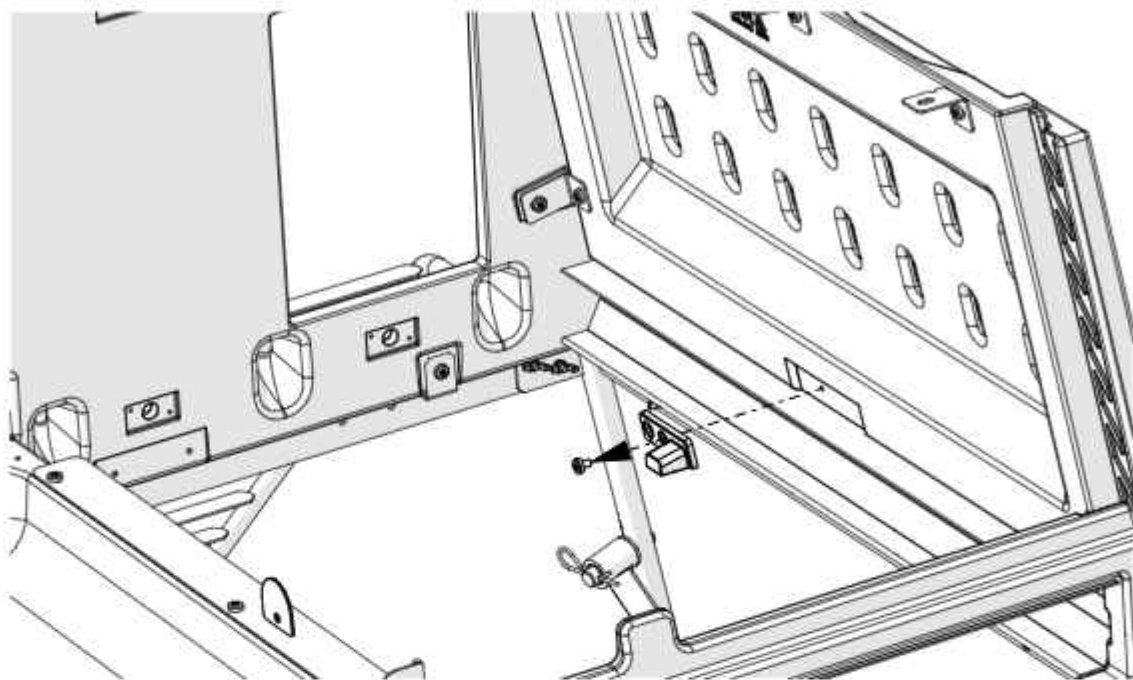

14



X1
800.0240



X1
064.1143

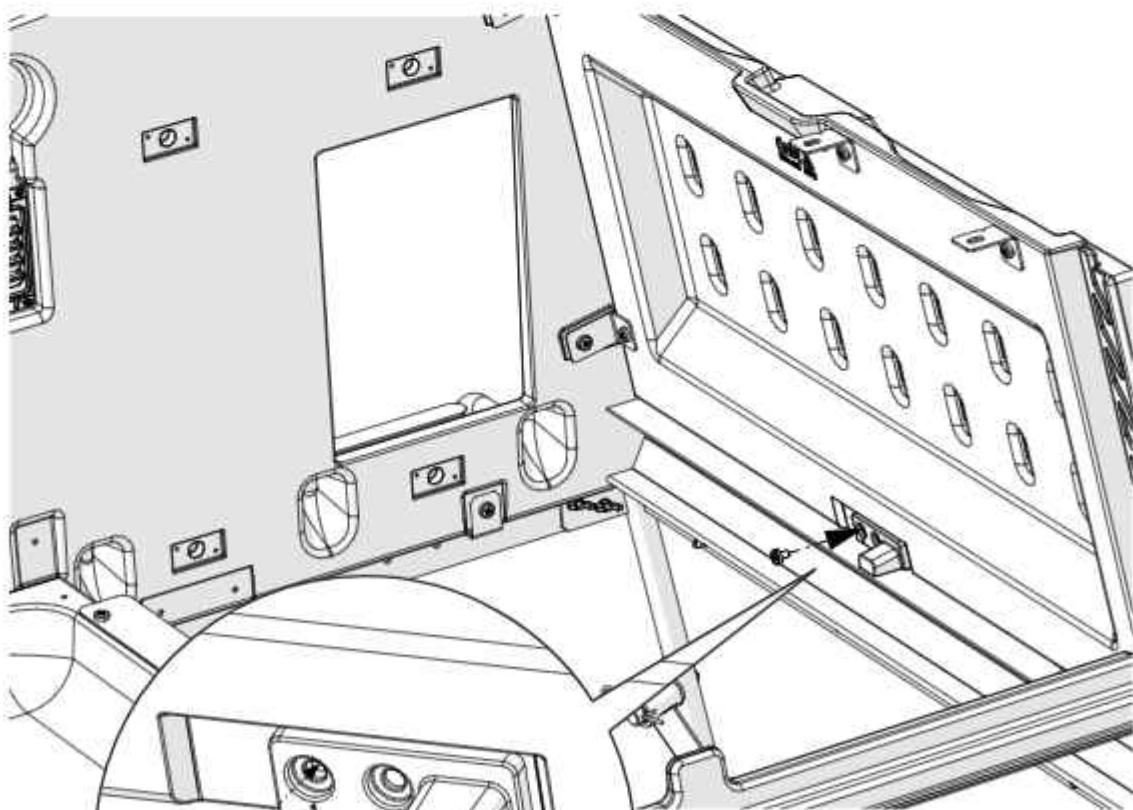

1

0

15

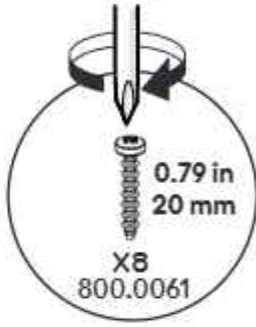
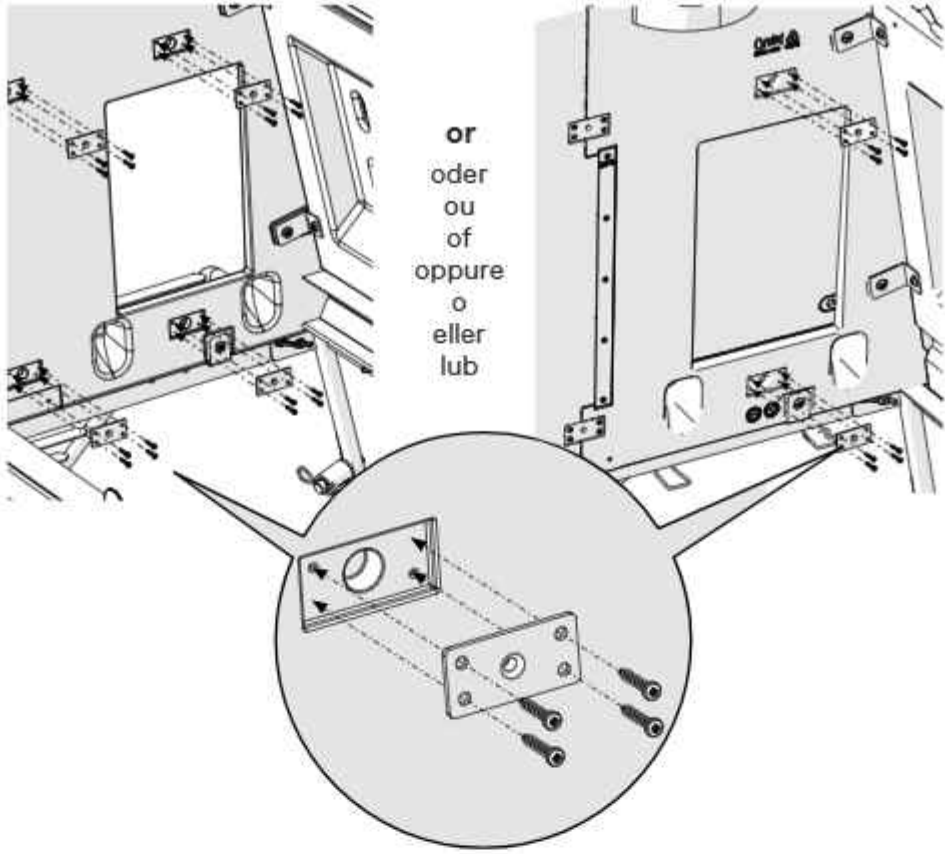

16

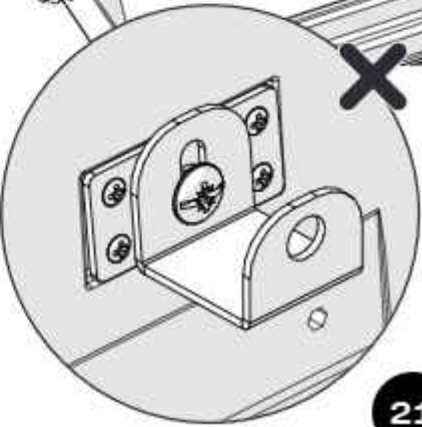
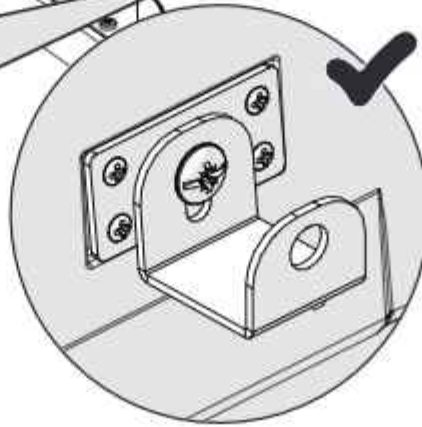
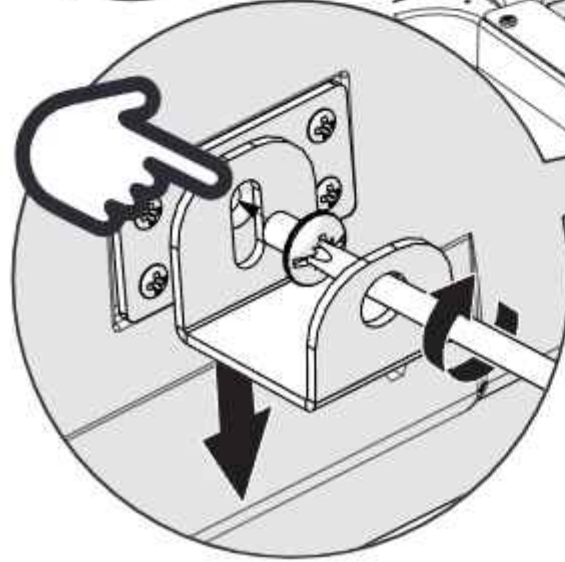
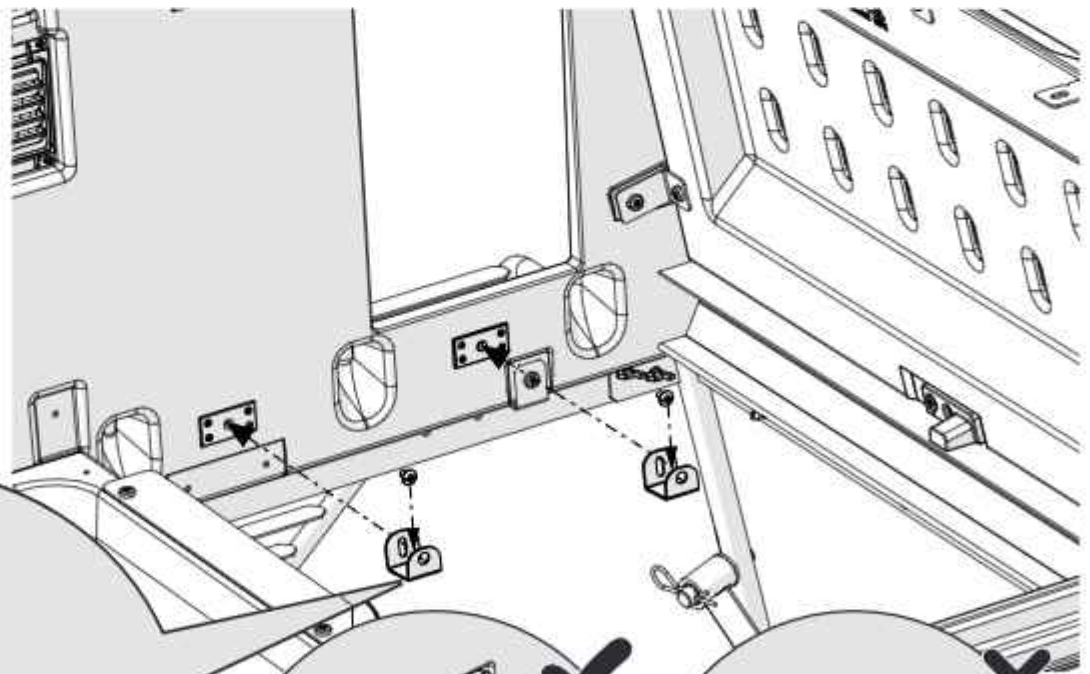

17

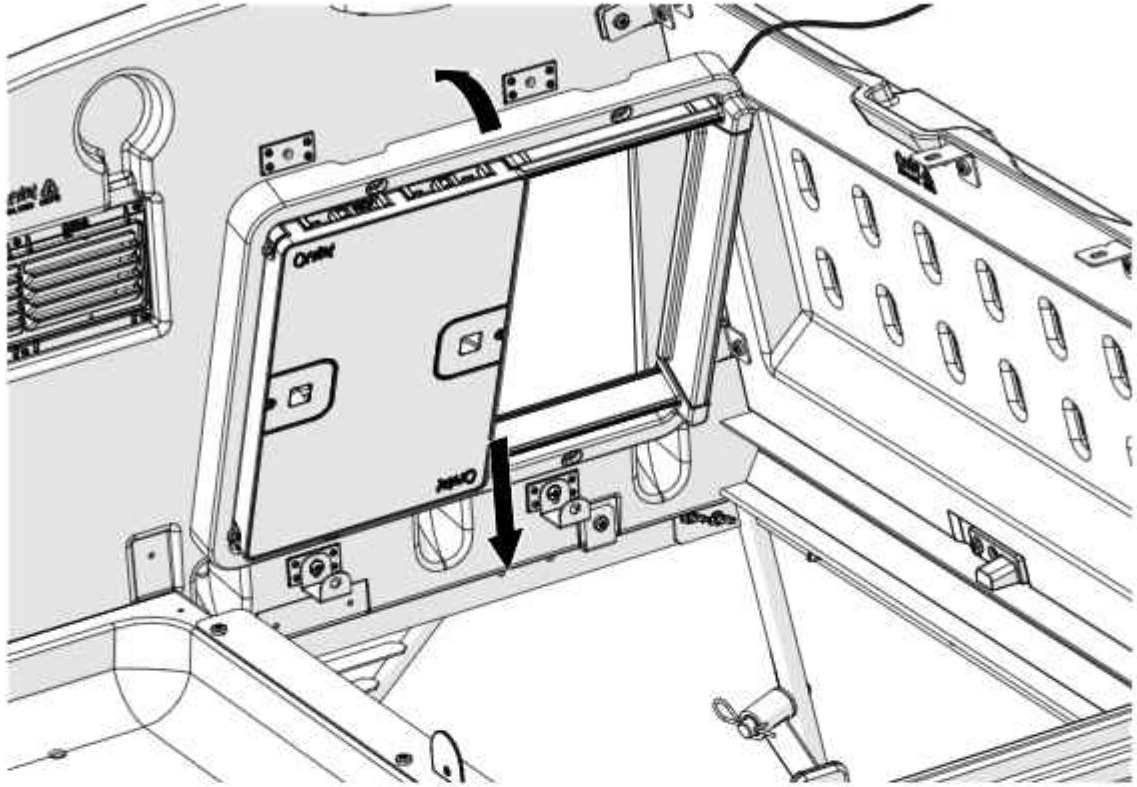

18

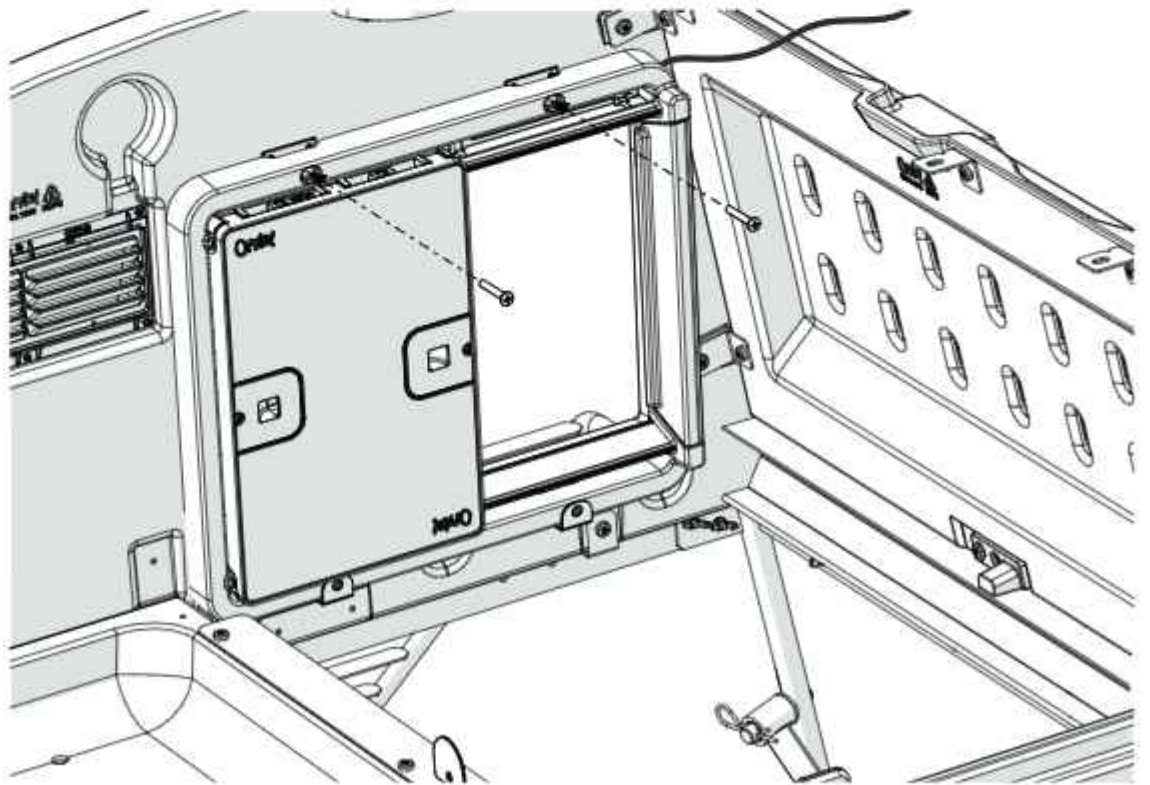

19

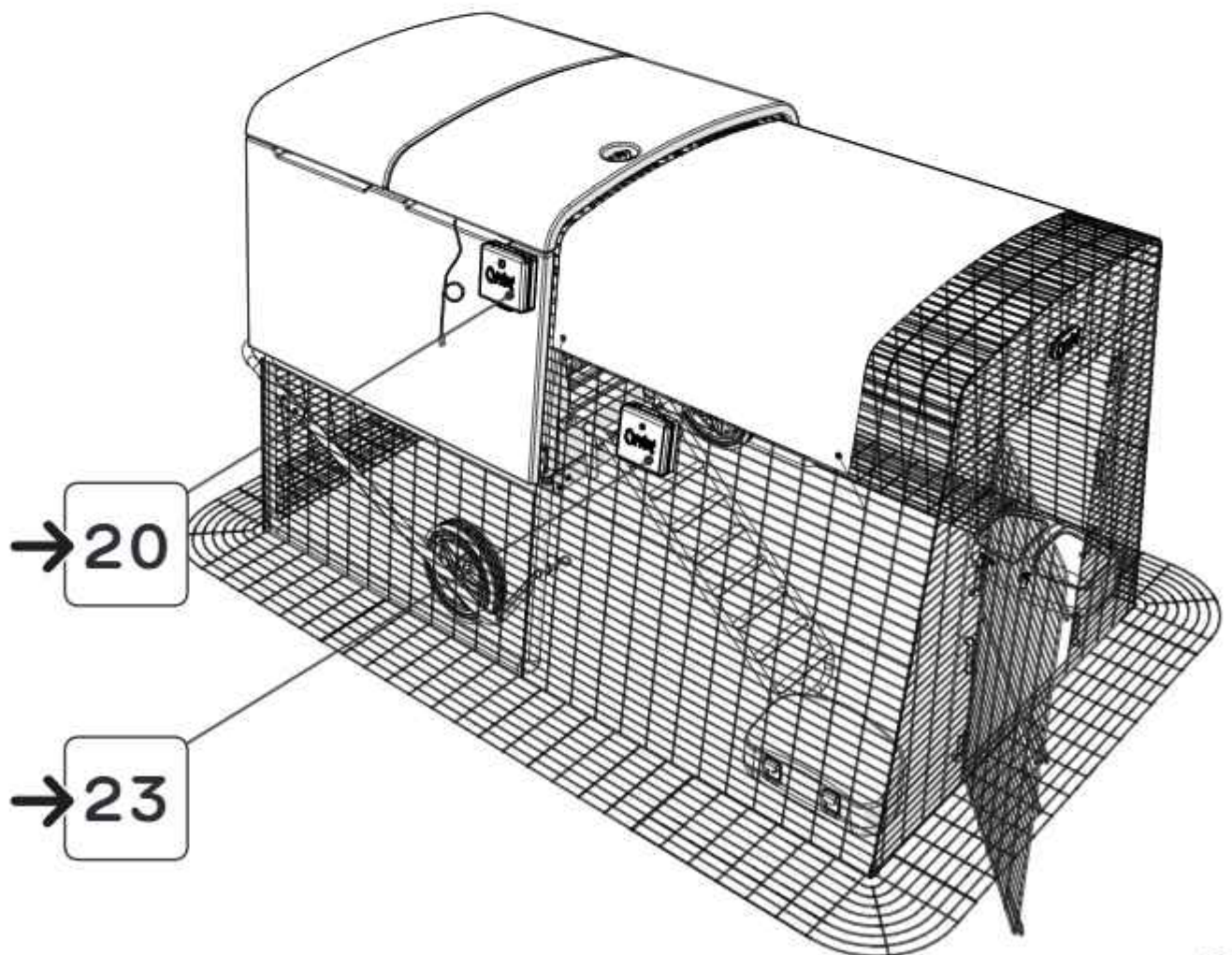
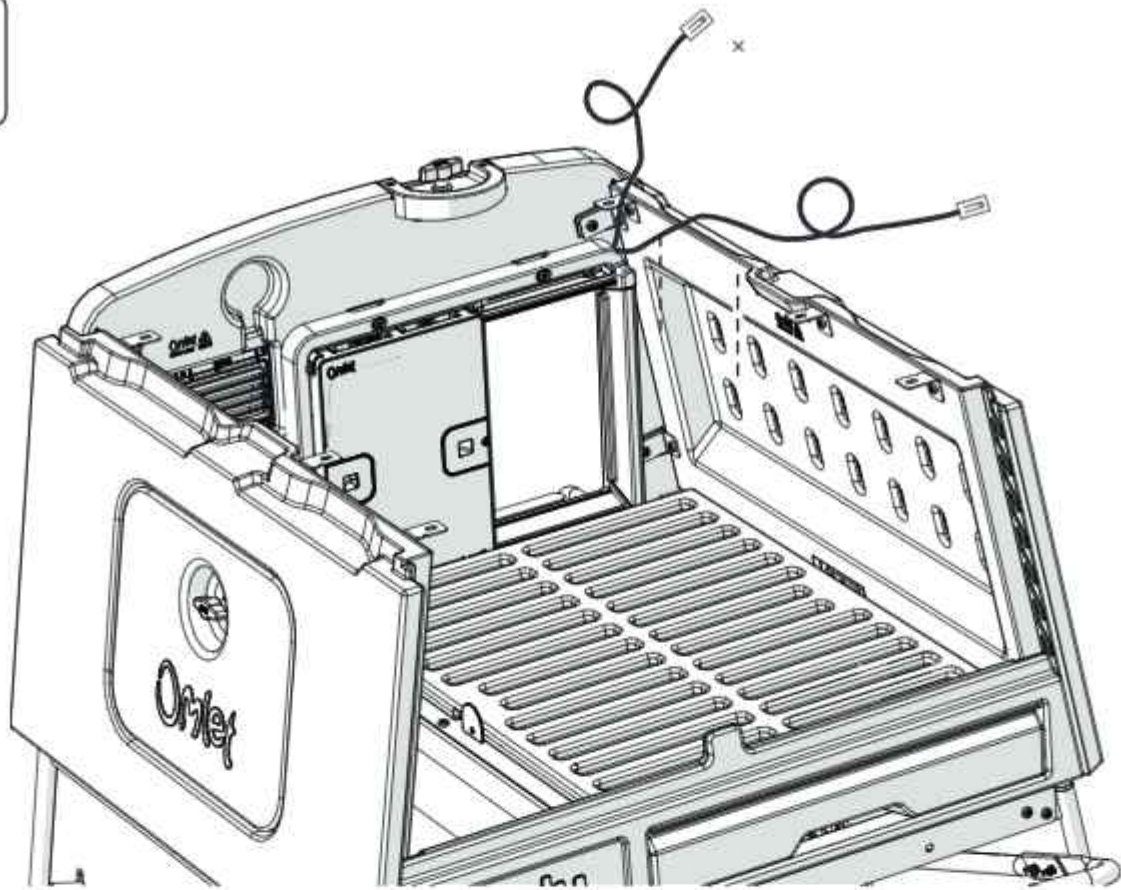

20 If you haven't removed the roof, you can remove one bolt at the front and pull the corner up to slide the bracket on.

DE Wenn Sie das Dach nicht entfernt haben, können Sie eine Schraube an der Vorderseite des Daches entfernen und die Ecke nach oben ziehen, damit die Halterung aufgeschoben werden kann.

FR Si vous n'avez pas retiré le toit, vous pouvez retirer un boulon à l'avant du toit et tirer le coin vers le haut pour permettre au support de glisser.

NL Als u het dak niet hebt verwijderd, kunt u één bout aan de voorkant van het dak verwijderen en de hoek naar boven trekken zodat de beugel kan schuiven

IT Se non hai rimosso il tetto, puoi rimuovere un bullone nella parte anteriore del tetto e tirare l'angolo verso l'alto per far scorrere la staffa.

SE Om du inte har tagit av taket kan du istället ta bort en bult på takets framsida och lyfta upp hörnet för att skjuta in fästet.

DK Hvis du ikke har fjernet taget, kan du fjerne en bolt på forsiden af taget og trække hjørnet op, så beslaget glider på.

+ 014.0056: Control Panel Mounting Bracket Eglu Cube Mk2 & Pro House

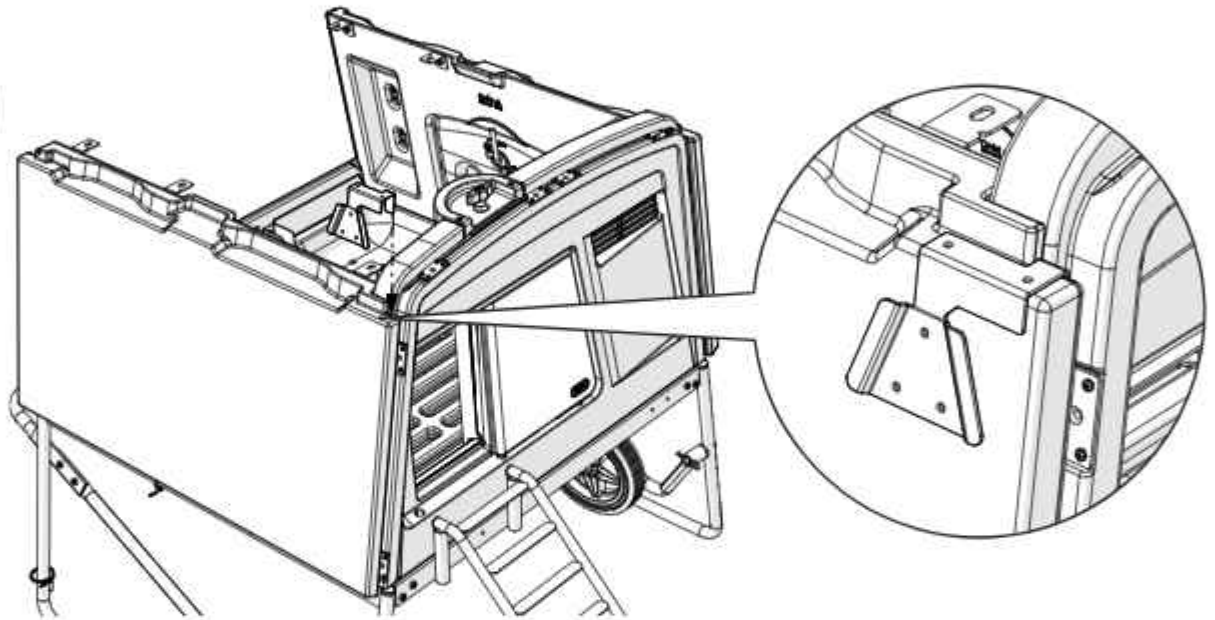

21

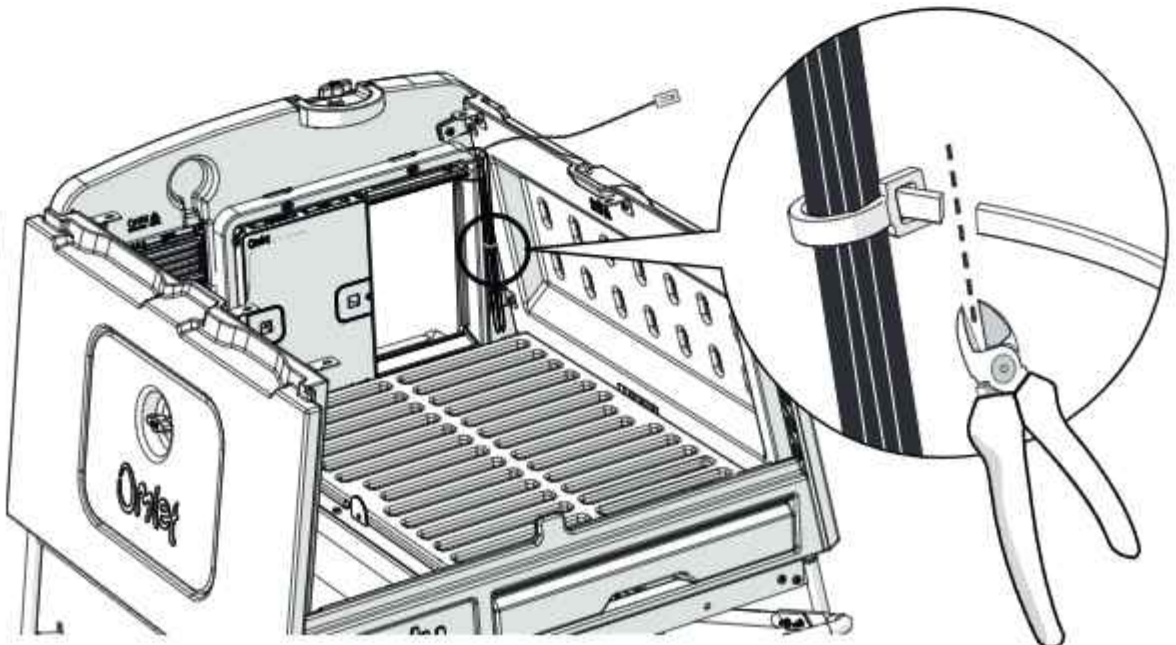

22

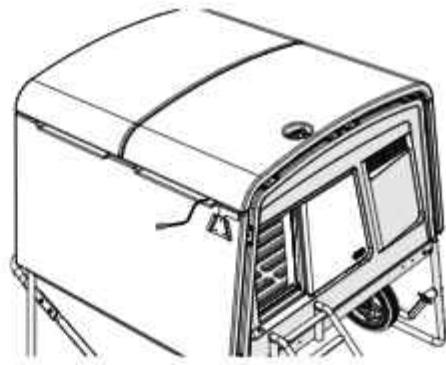

→ 48

23

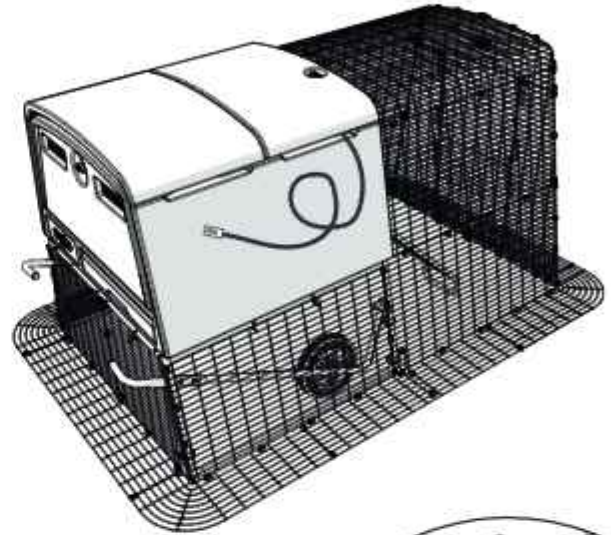
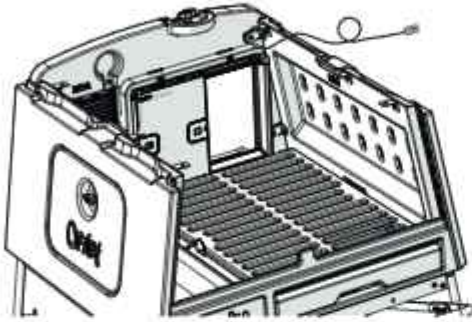

24



X1
014.1135



X3
800.0103

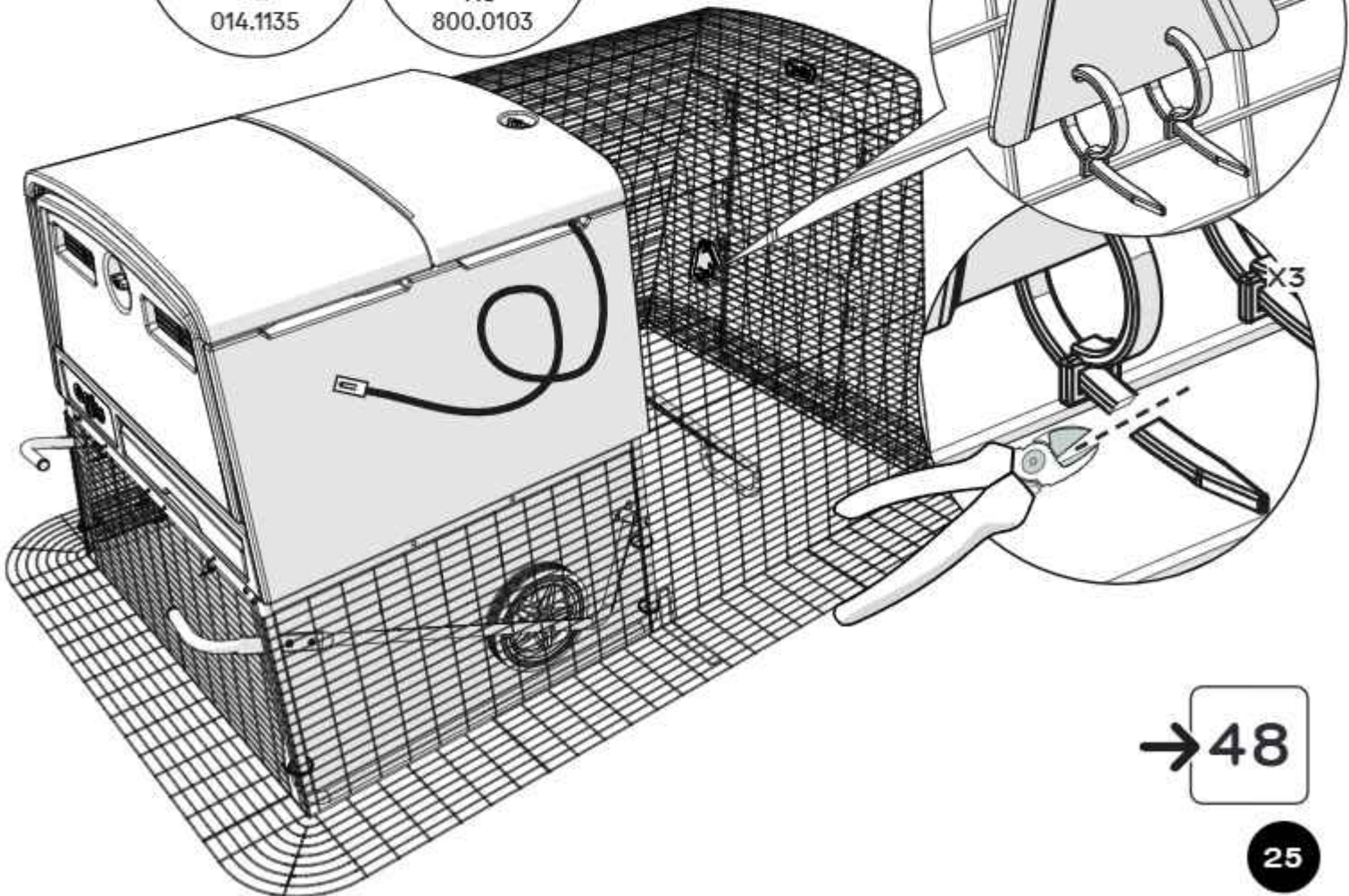

→ 48

Attach the door to Eglu Pro

DE Bringe die Tür am Eglu Pro an · FR Fixer la porte automatique au poulailler Eglu Pro · NL Bevestig de deur aan de Eglu Pro · IT Collegare la Porta Automatica a Eglu Pro · SE Montera dörren på Eglu Pro · DK Fastgør døren til Eglu Pro

25

Roof removal optional



DE Die Entfernung des Daches ist optional · FR Le retrait du toit est facultatif · NL Verwijderen van het dak is optioneel · IT La rimozione del tetto è facoltativa · SE Takavlägsnande är valfritt · DK Fjernelse af taget er valgfrit

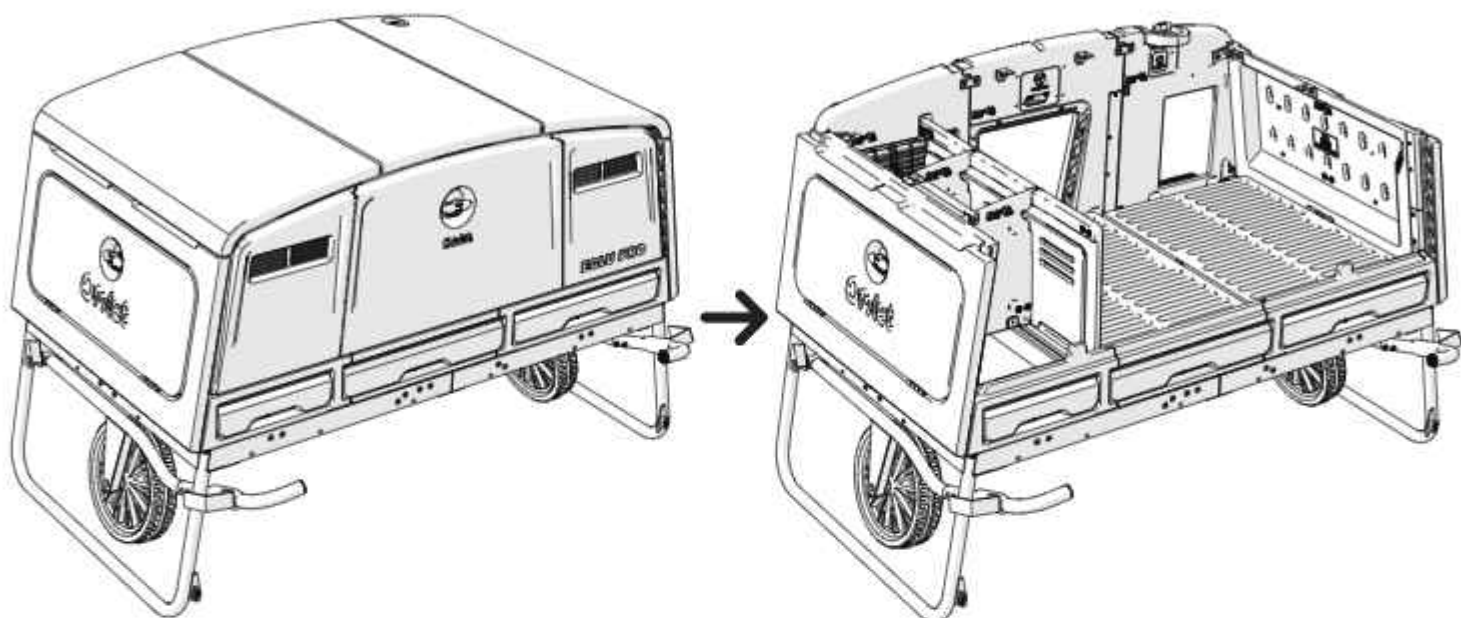

26

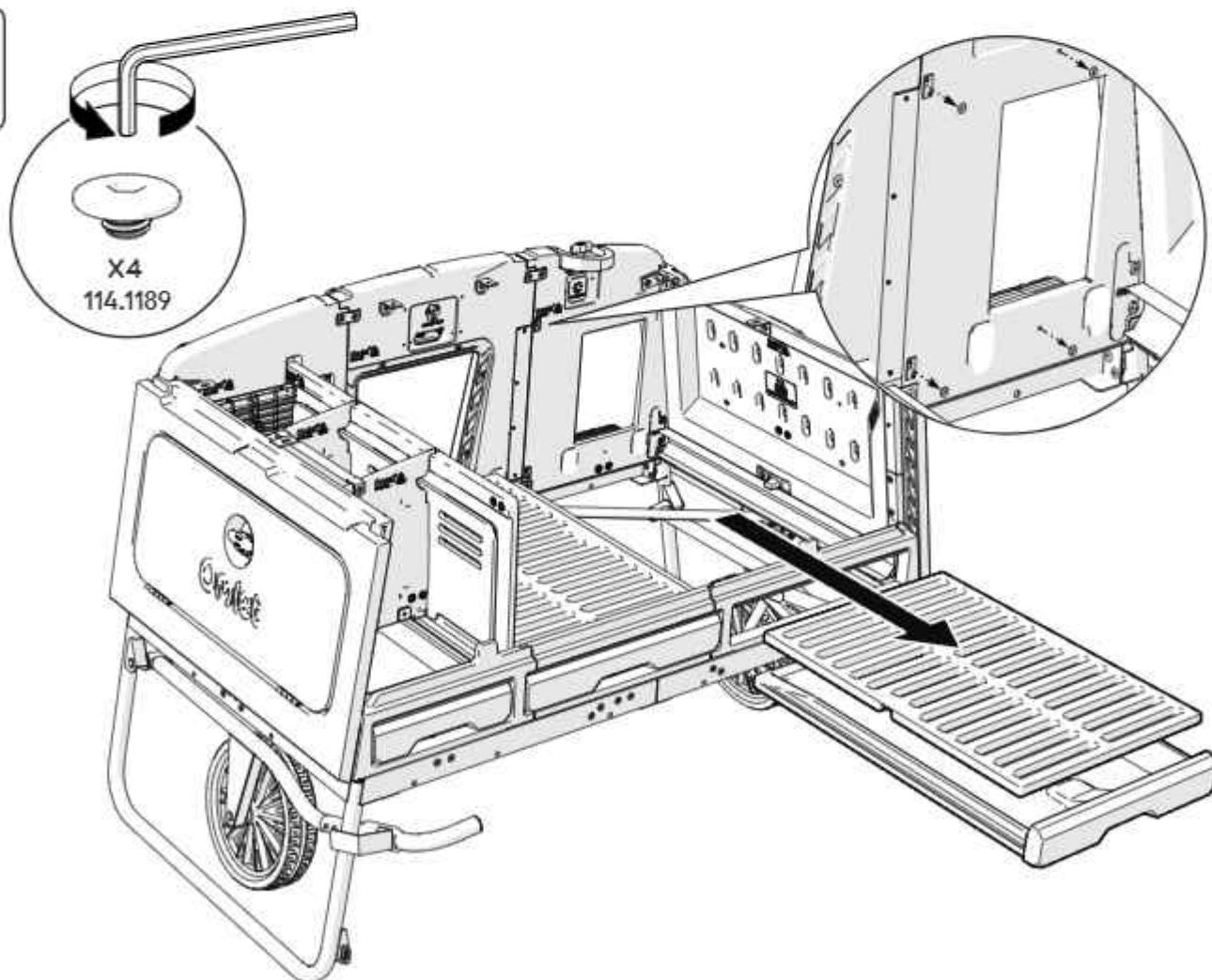

27**Keep the Parts safe until Step 28**

- DE Legen Sie die Teile bis Schritt 28 beiseite
- FR Mettez ces pièces de côté pour l'étape 28
- NL Leg de onderdelen opzij tot stap 28
- IT Mettere da parte fino al Punto 28
- SE Lägg undan delarna till Steg 28
- DK Læg delene til side indtil trin 28

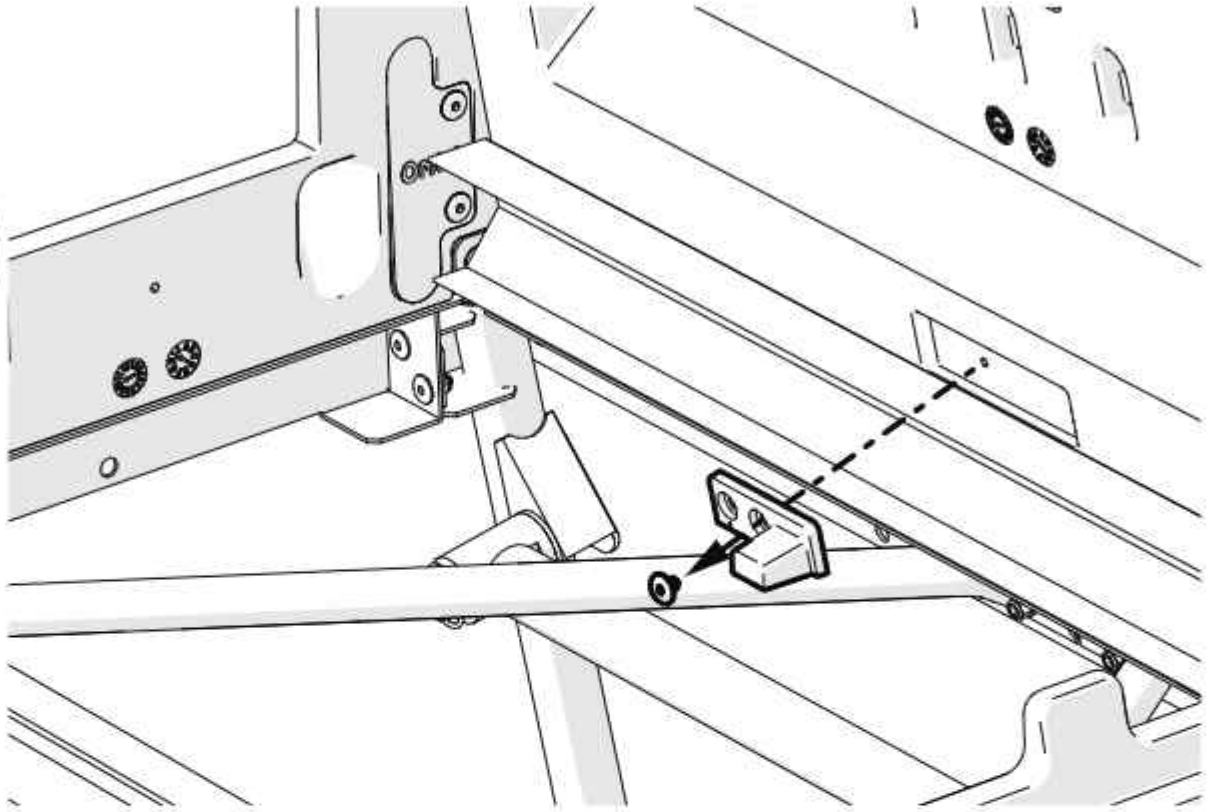
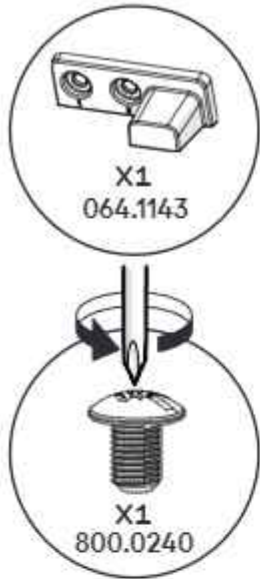
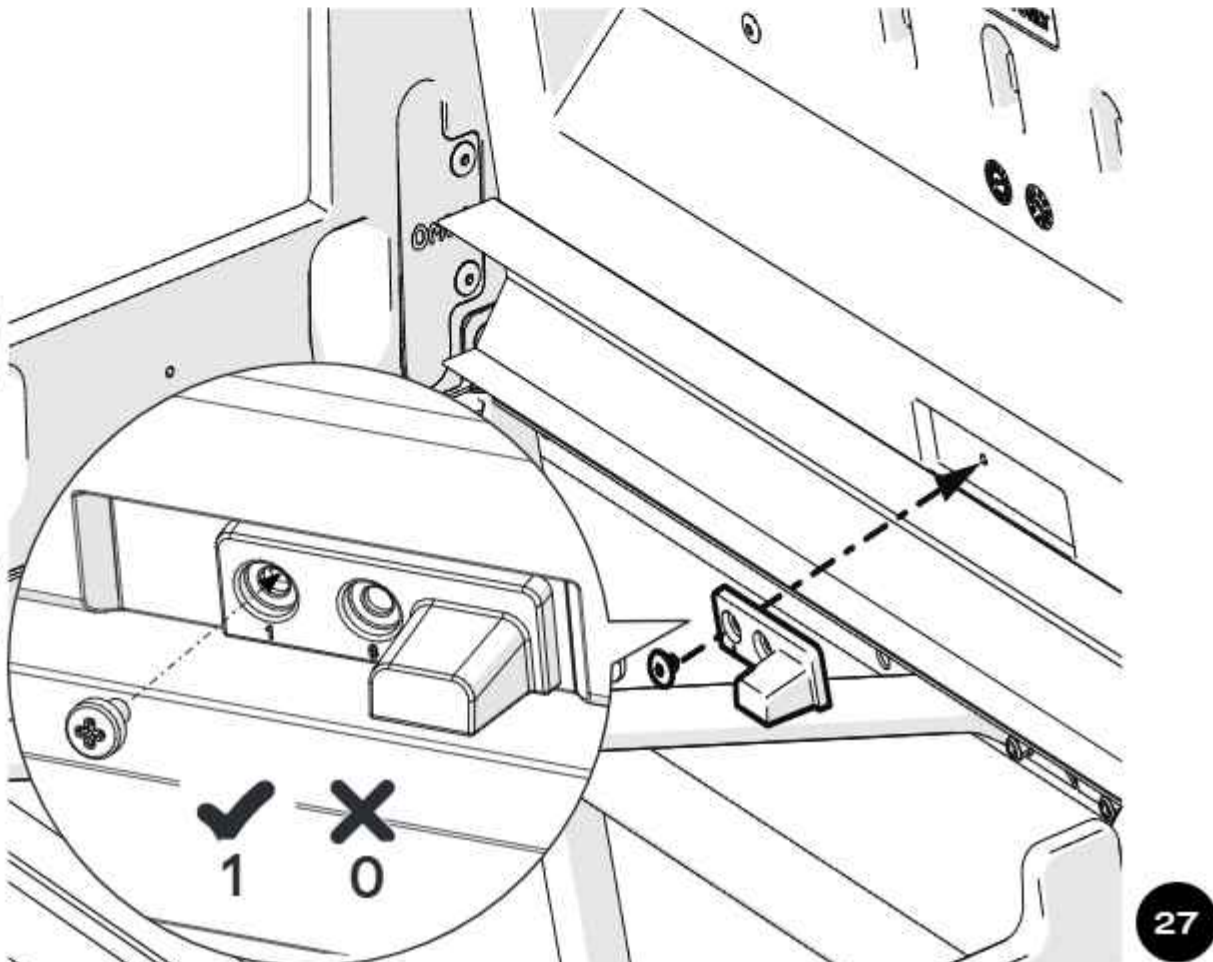
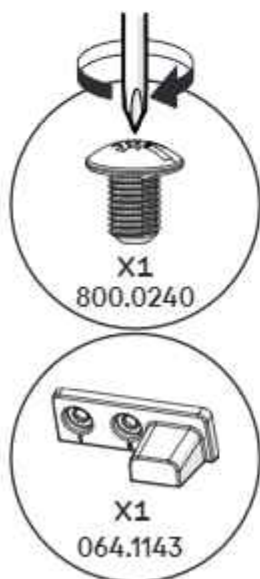
**28**

29

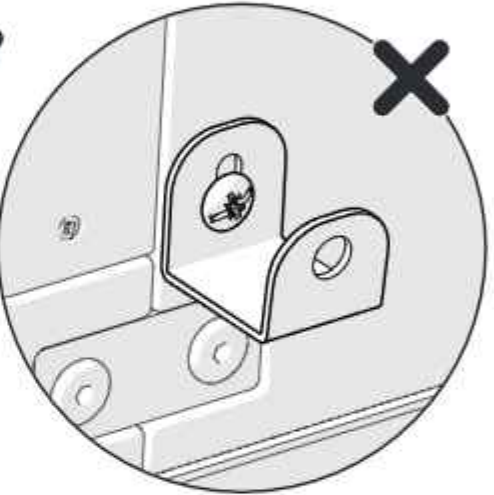
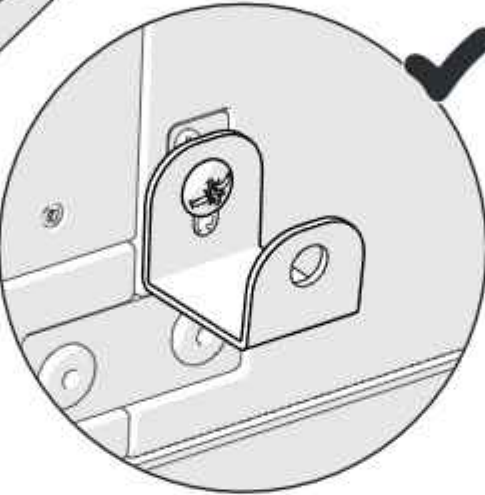
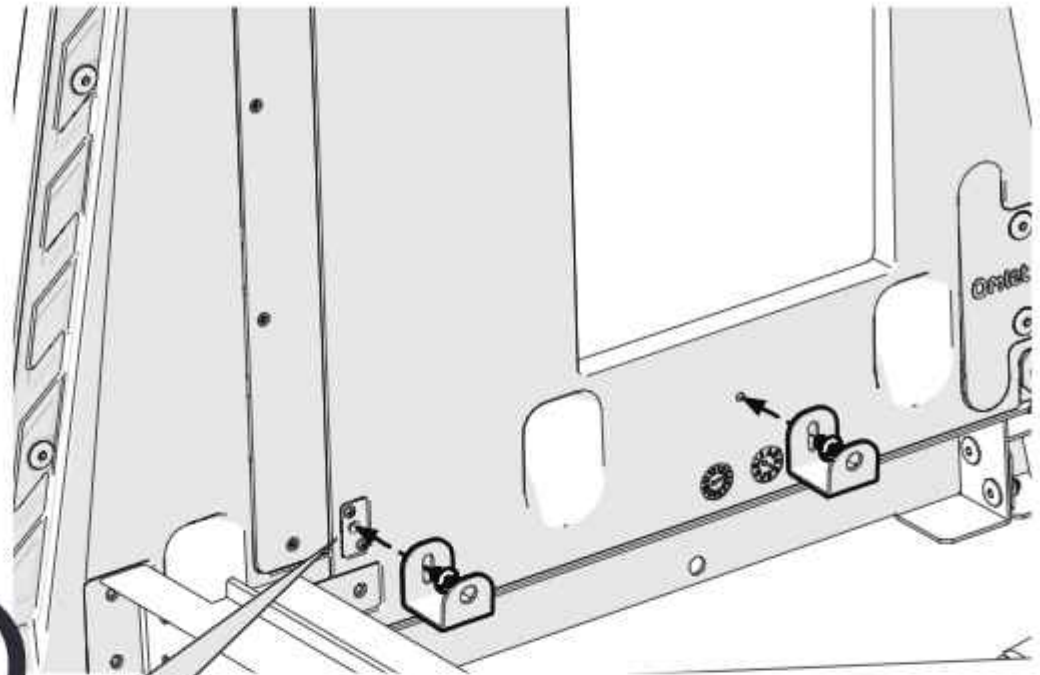

30

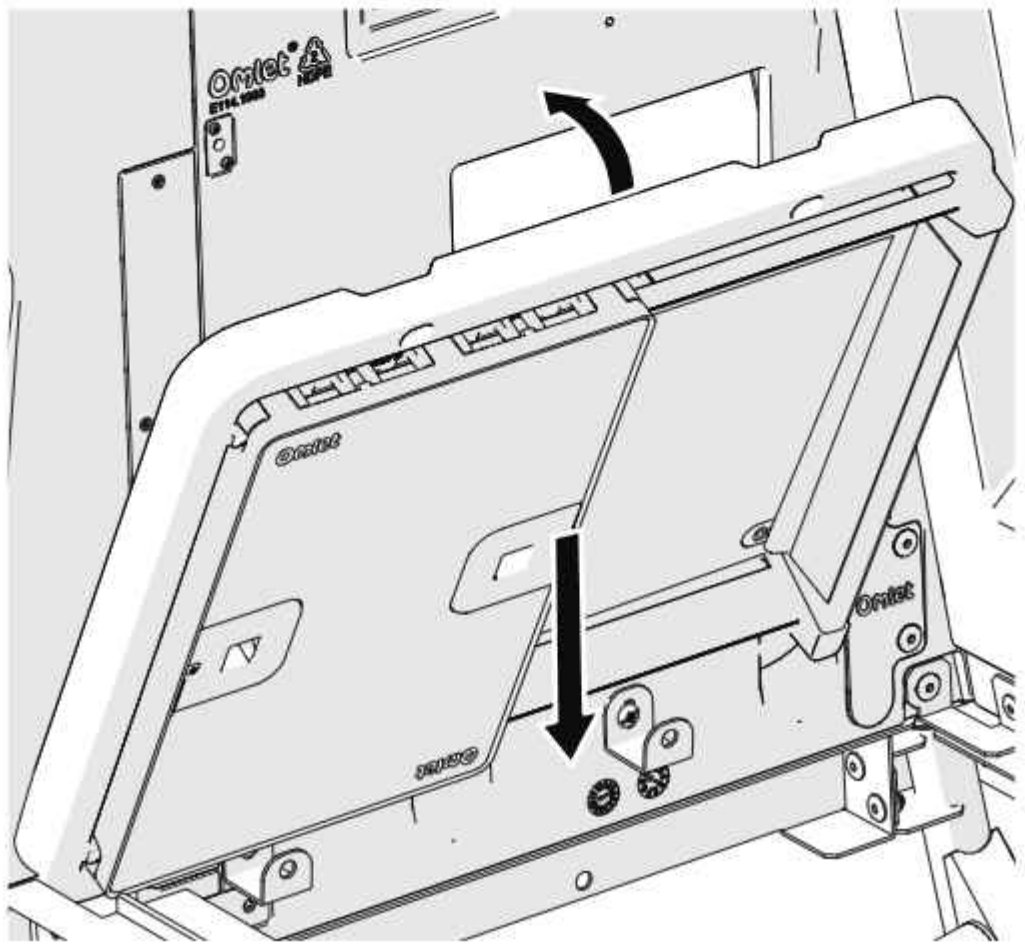

28

31

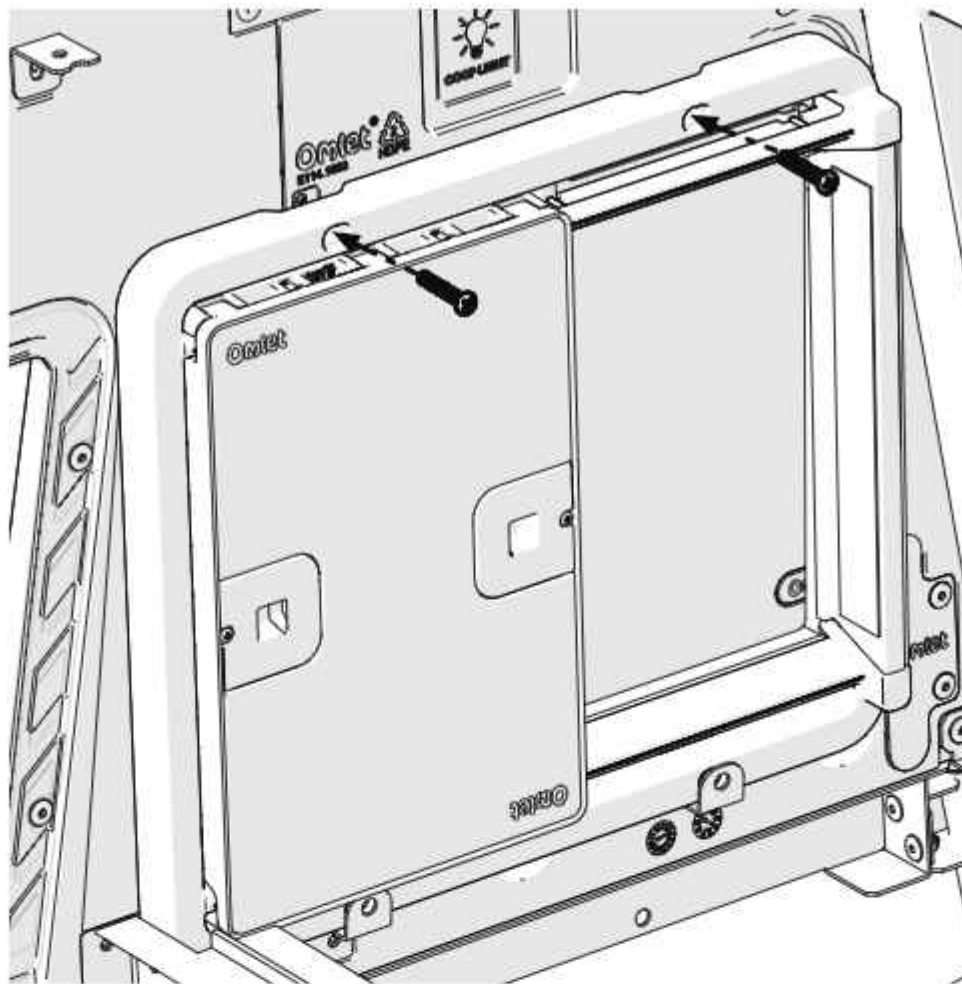

32

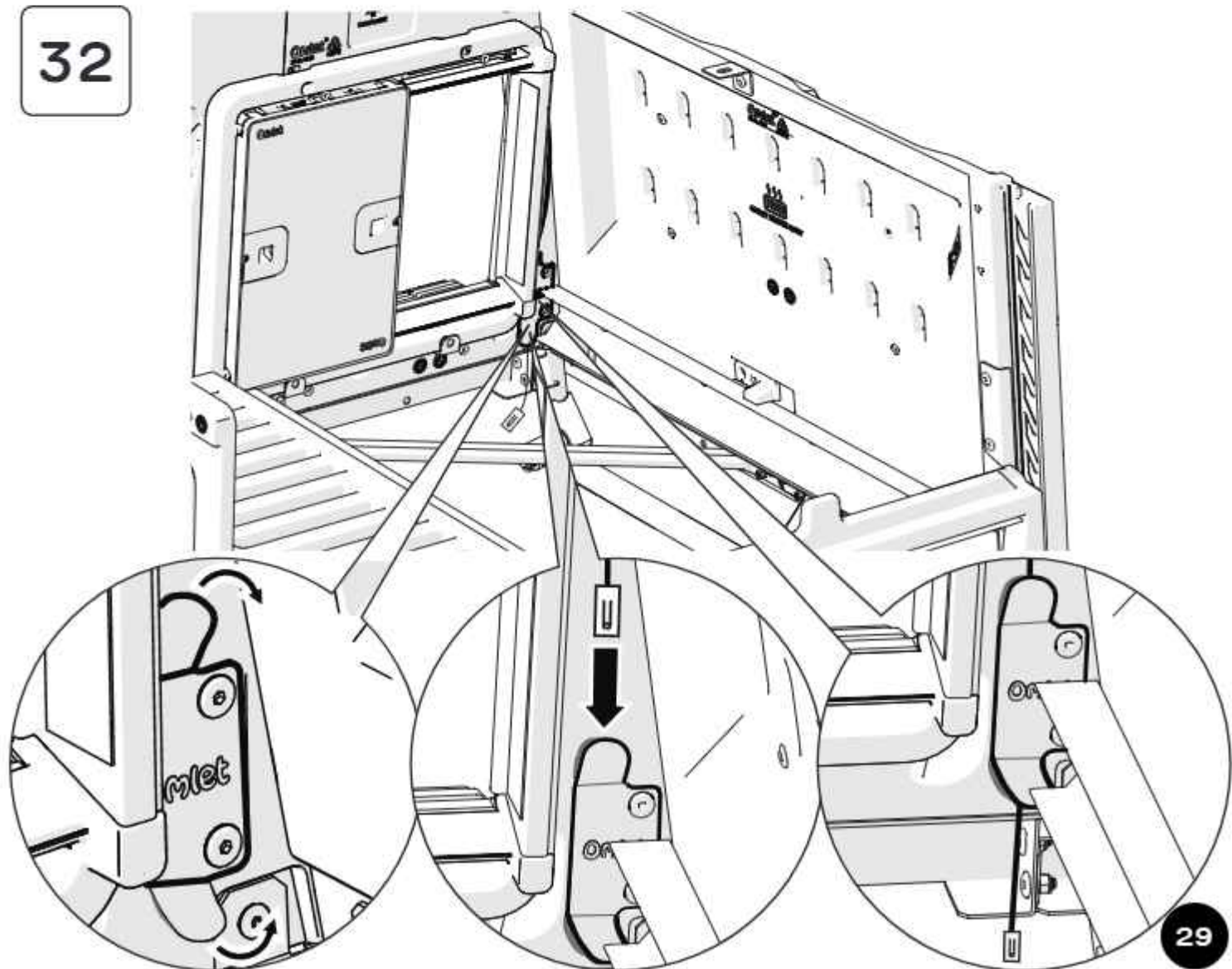

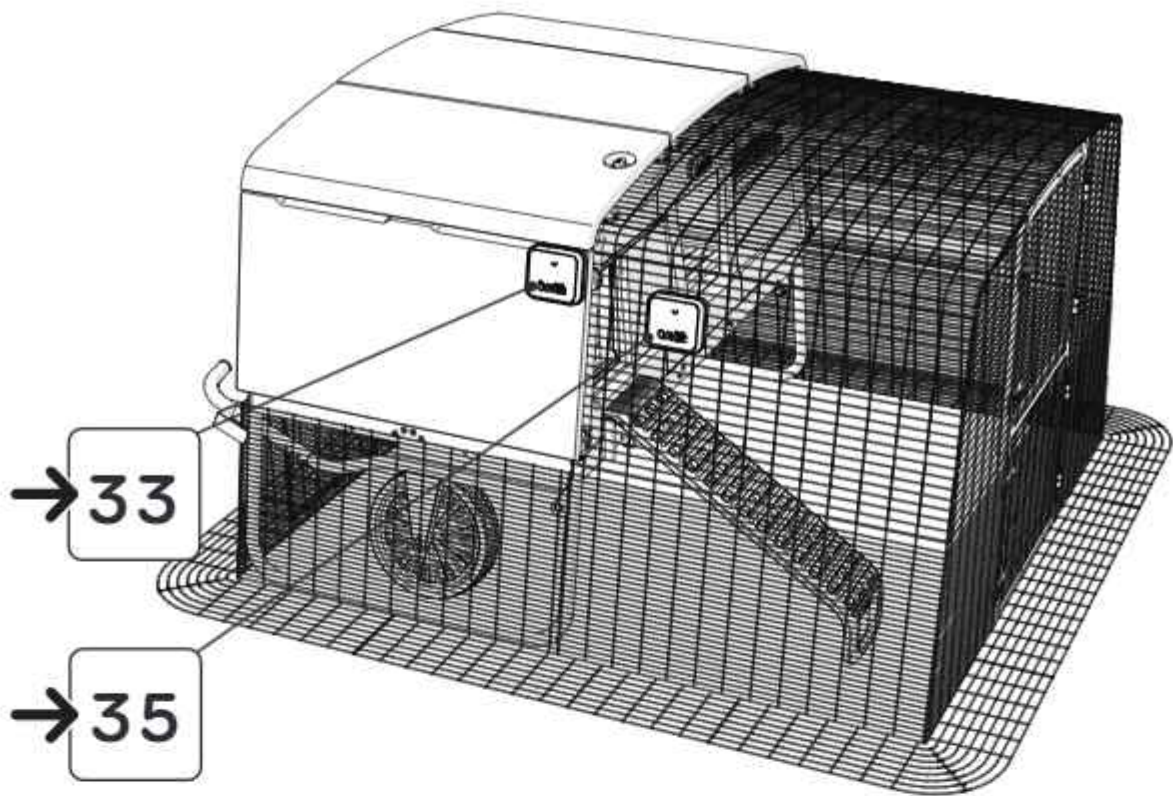

33 If you haven't removed the roof, you can remove one bolt at the front and pull the corner up to slide the bracket on.

DE Wenn Sie das Dach nicht entfernt haben, können Sie eine Schraube an der Vorderseite des Daches entfernen und die Ecke nach oben ziehen, damit die Halterung aufgeschoben werden kann.

FR Si vous n'avez pas retiré le toit, vous pouvez retirer un boulon à l'avant du toit et tirer le coin vers le haut pour permettre au support de glisser.

NL Als u het dak niet hebt verwijderd, kunt u één bout aan de voorkant van het dak verwijderen en de hoek naar boven trekken zodat de beugel kan schuiven

IT Se non hai rimosso il tetto, puoi rimuovere un bullone nella parte anteriore del tetto e tirare l'angolo verso l'alto per far scorrere la staffa.

SE Om du inte har tagit av taket kan du istället ta bort en bult på takets framsida och lyfta upp hörnet för att skjuta in fästet.

DK Hvis du ikke har fjernet taget, kan du fjerne en bolt på forsiden af taget og trække hjørnet op, så beslaget glider på.

+ 014.0056: Control Panel Mounting Bracket Eglu Cube Mk2 & Pro House

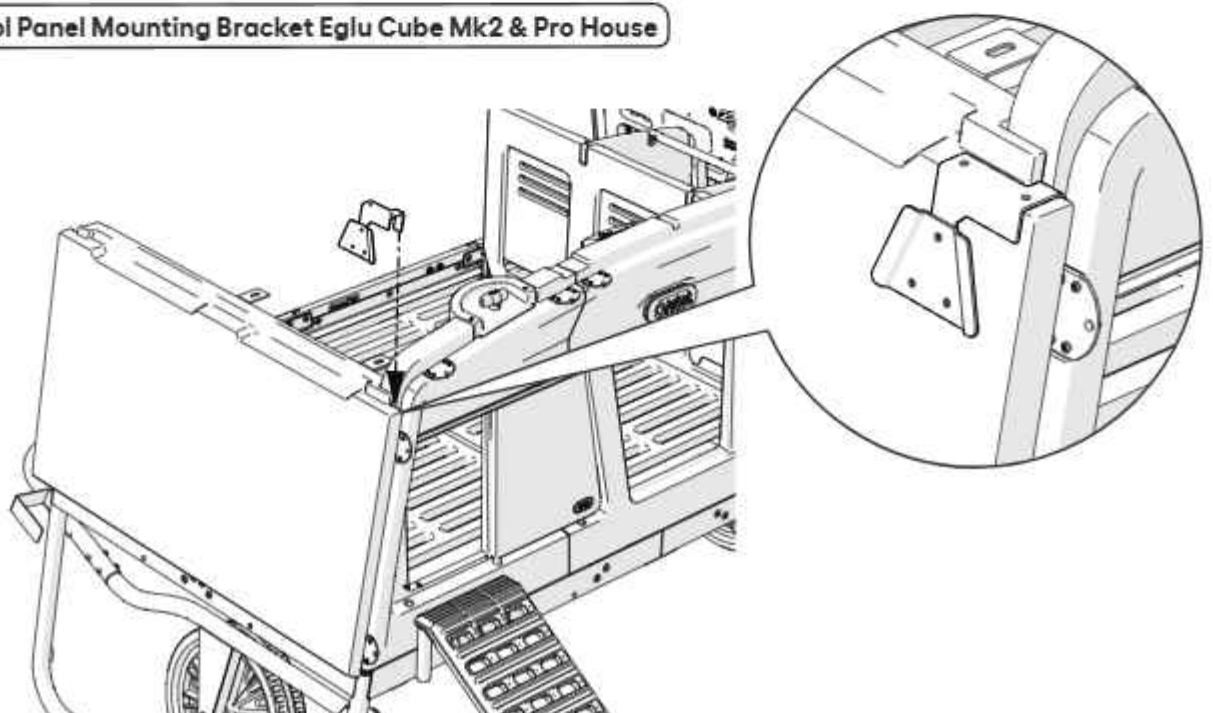

34

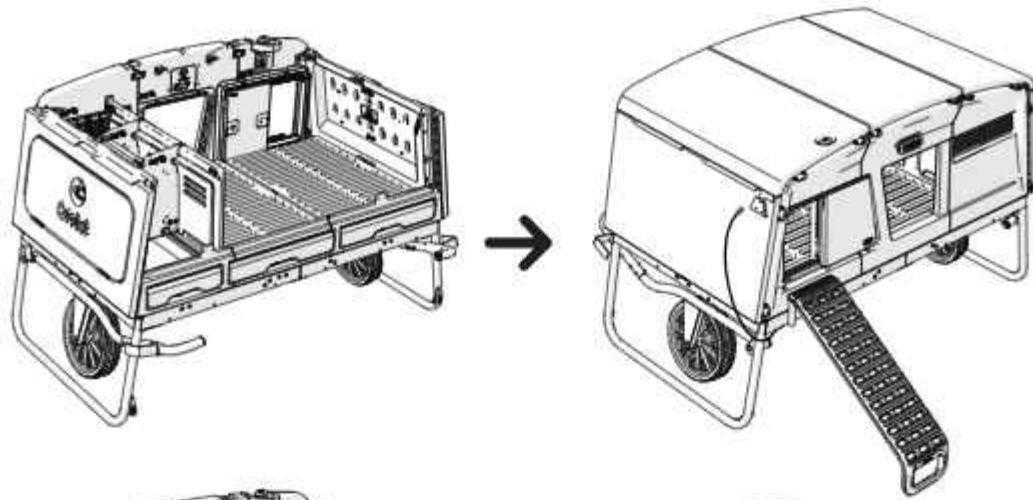

→ 48

35

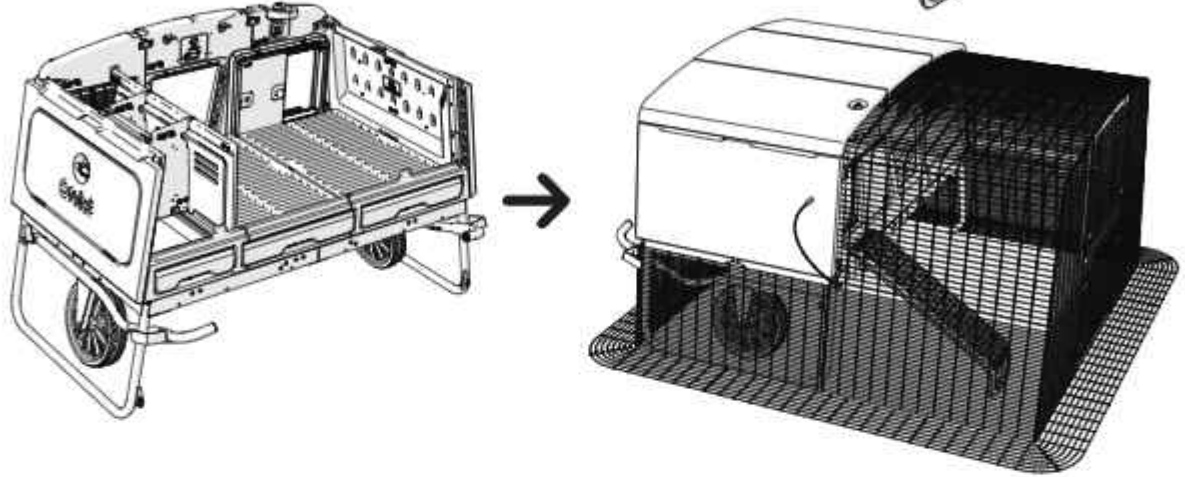

36

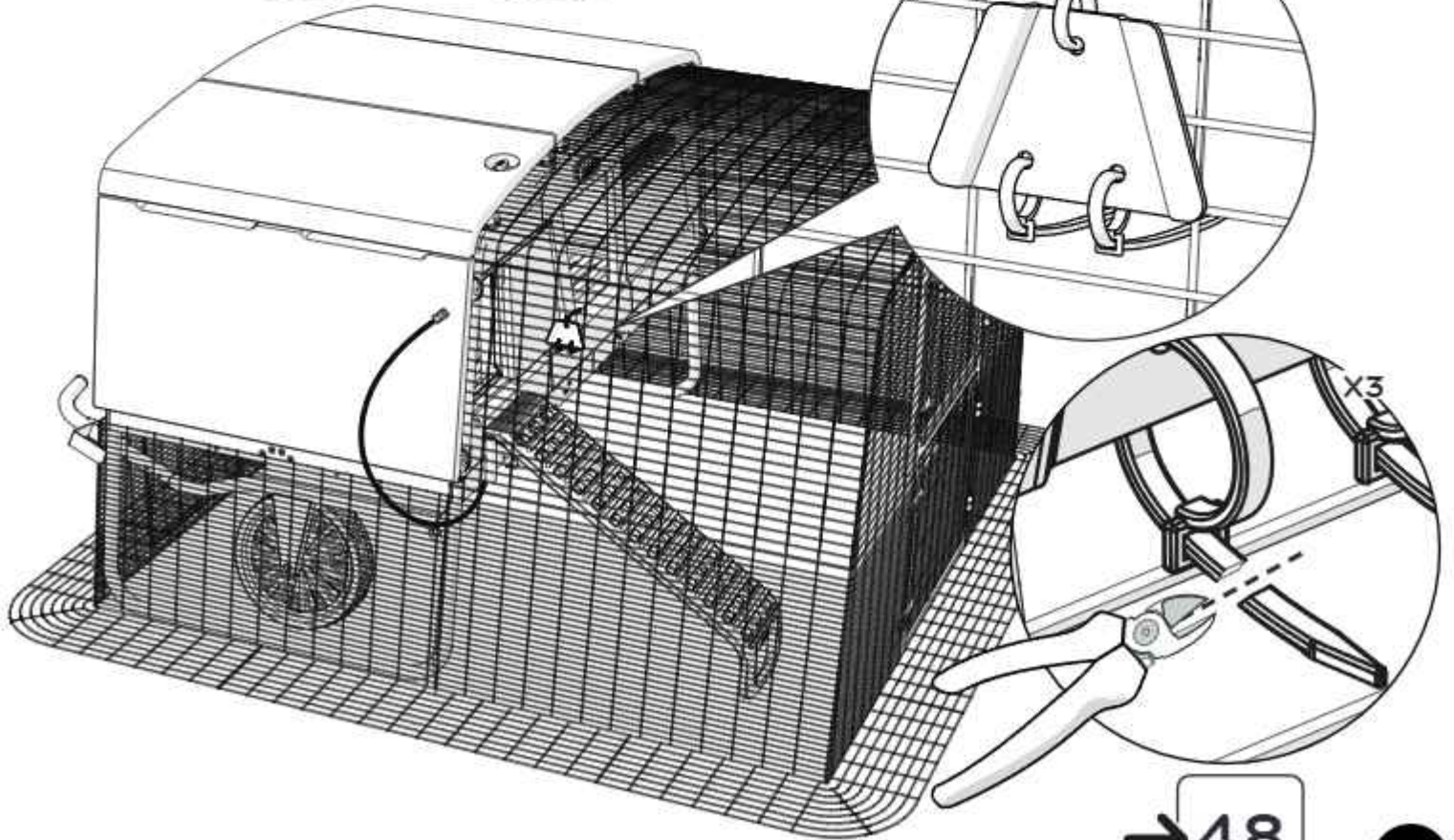
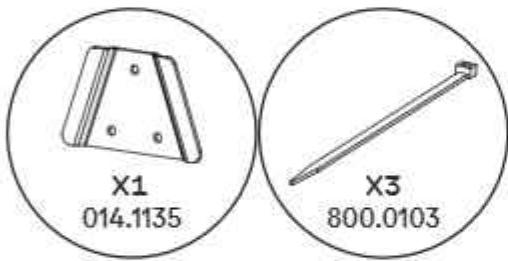

→ 48

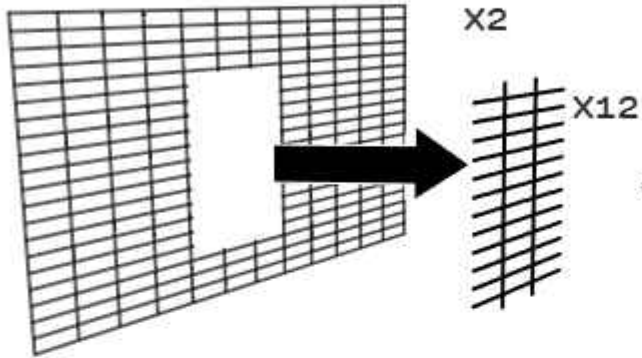
37**Attach the door to Omlet mesh****DE** Die Tür an einem Drahtgitter von Omlet befestigen · **FR** Fixation du cadre sur filet Omlet**NL** De deur bevestigen op Omlet gaas · **IT** Attaccare la Porta al pannello Omlet · **SE** Montera dörren på nät från Omlet · **DK** Montering af døren på hønsenet fra Omlet**810.0074 Mesh Edge Protector Kit**

or
oder · ou · of · oppure
o · eller · lub

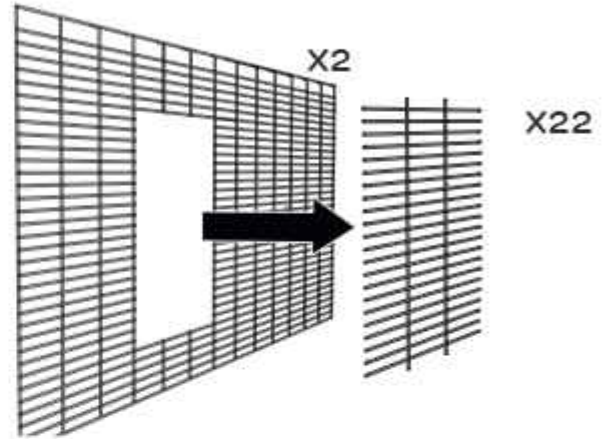
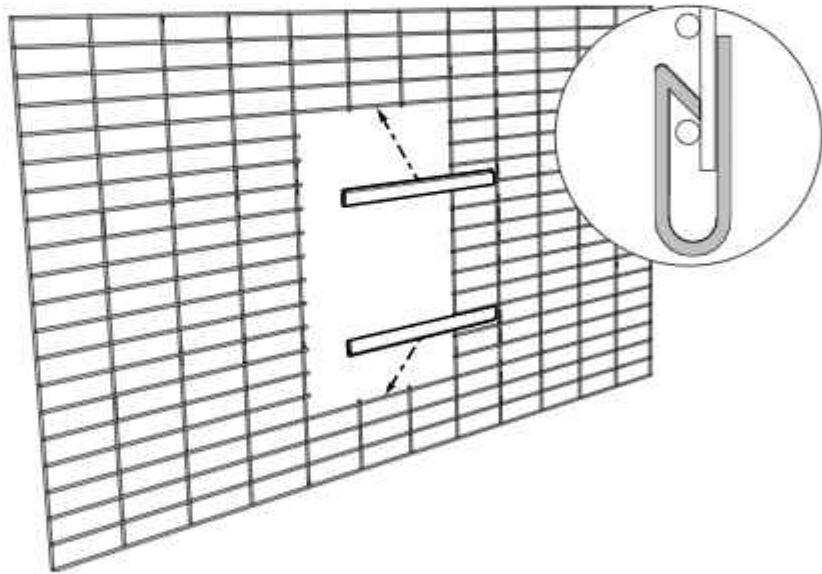
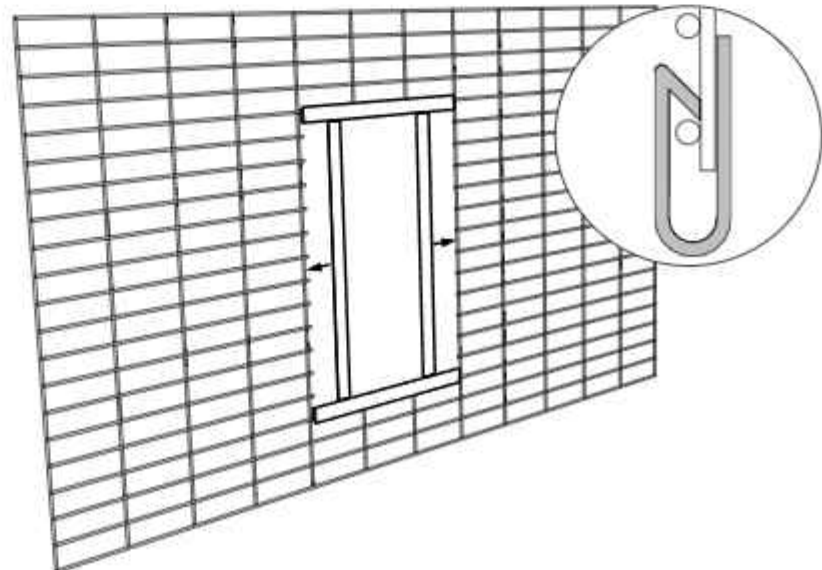
**38****39**

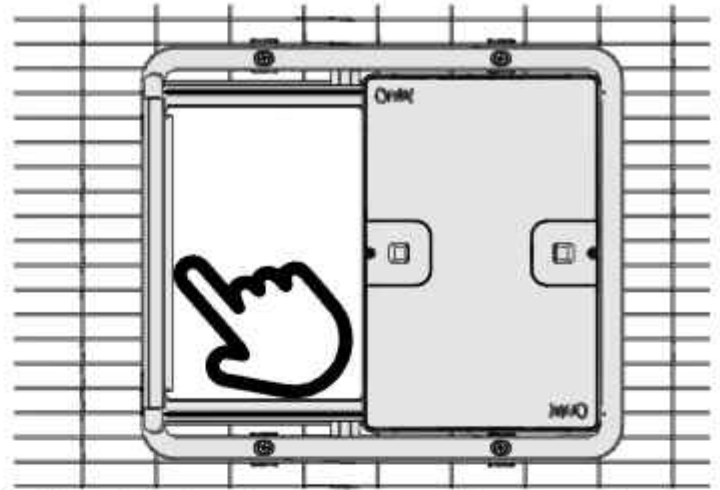
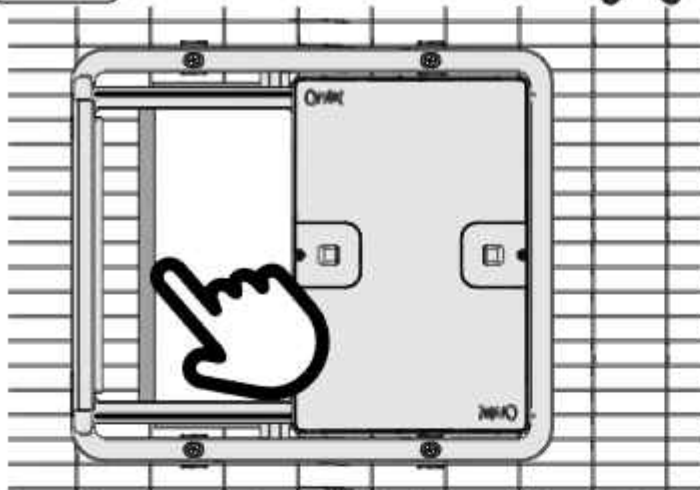

The safety sensor bar which detects if an object is blocking the door from closing will only work properly if the door is installed correctly. In the image to the left the opening of the coop is smaller than the opening of the Autodoor. In this case the Autodoor's safety sensor bar might not operate correctly. To solve this move the Autodoor so that the opening is set back from the edge of the safety bar by at least 0.2 in (5 mm) like in the picture to the right...

· **DE** Die Sicherheitssensorleiste, die erkennt, ob ein Gegenstand die Tür am Schließen hindert, funktioniert nur dann richtig, wenn die Tür korrekt eingebaut ist. Im linken Bild ist die Öffnung des Stalls kleiner als die Öffnung der Autodoor. In diesem Fall ist es möglich, dass die Sicherheitssensoren der Autodoor nicht richtig funktionieren. Um dies zu beheben, versetze die Autodoor so, dass die Öffnung mindestens 5 mm von der Kante der Sicherheitssensorleiste entfernt ist, wie im rechten Bild zu sehen ist ...

· **FR** La barre du capteur de sécurité, qui détecte l'éventuelle présence d'un objet entre elle et la porte pour l'empêcher de se fermer, ne fonctionnera que si la Porte Automatique est installée correctement. Sur l'image de gauche, l'ouverture du poulailler est plus petite que celle de la porte. Dans un cas comme celui-ci, il se peut que la barre du capteur ne fonctionne pas correctement. Pour y remédier, déplacez simplement la porte afin qu'il y ait au moins 5 mm entre l'ouverture du poulailler et la barre de sécurité (voir image de droite)...

· **NL** De veiligheidssensorbalk die detecteert of het sluiten van de deur geblokkeerd wordt door een object, werkt alleen goed als de deur correct is geïnstalleerd. In de afbeelding links is de opening van het kippenhok kleiner dan de opening van de Autodoor. In dit geval werkt de veiligheidssensorbalk van de Autodoor mogelijk niet correct. Om dit op te lossen verplaatst u de Autodoor dusdanig dat de opening minimaal 5 mm naar achteren ligt ten opzichte van de rand van de veiligheidssensorbalk, zoals op de afbeelding rechts...

· **IT** Il sensore di sicurezza che rileva se un oggetto sta ostruendo la porta e le impedisce la chiusura, funziona correttamente solo se la porta è stata installata in maniera adeguata. Nell'immagine a sinistra potete osservare che la porta del pollaio è più piccola dell'apertura dell'Autodoor. In questo caso il sensore di sicurezza dell'Autodoor non funzionerà correttamente. Potete facilmente risolvere il problema spostando l'Autodoor in modo che l'apertura sia distante dal bordo della barra del sensore di sicurezza almeno di 5 mm, come nel disegno a destra...

· **SE** Säkerhetssensorn som känner av om någonting blockerar dörren kommer bara fungera om dörren är installerad på rätt sätt. På bilden till vänster kan du se att öppningen på hönsuset är mindre än öppningen på Autodörren. Då finns en risk att säkerhetssensorn inte fungerar som den ska. Det är väldigt lätt att lösa genom att flytta Autodörren så att öppningen sitter åtminstone 5mm från kanten på säkerhetssensorn, som på bilden till höger...

· **DK** Sikkerhedssensorbjælken, der registrerer, om en genstand blokerer døren fra at lukke, fungerer kun korrekt, hvis døren er installeret korrekt. På billedet til venstre er åbningen af hønsesuset mindre end åbningen af Autodoor. I dette tilfælde fungerer Autodoors sikkerhedssensorbjælke muligvis ikke korrekt. For at løse dette problem skal du flytte Autodoor, så åbningen er sat mindst 5 mm tilbage fra kanten af sikkerhedsbjælken som på billedet til højre...

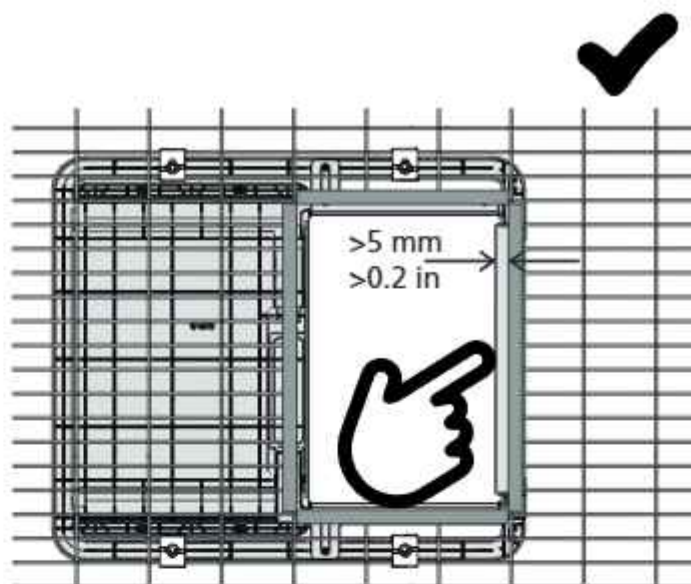
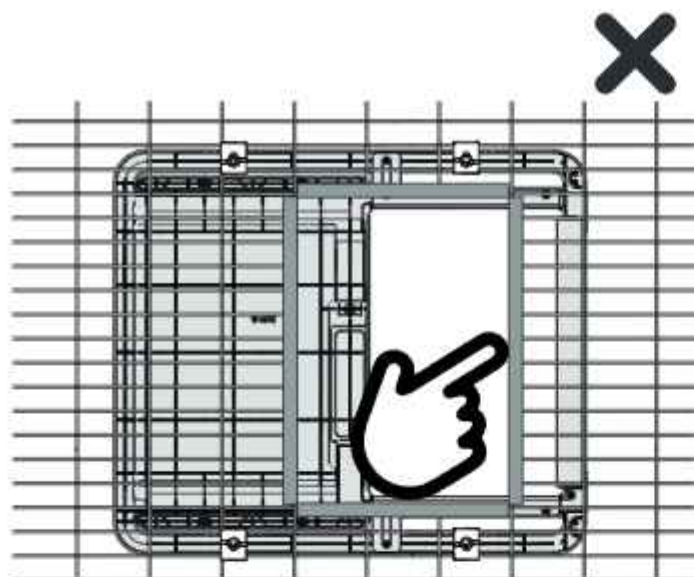

...Seen from the other side, you can also see the opening of the coop is not obstructing the safety bar. You can watch the installation video by scanning the code or visiting:
www.omlet.co.uk/instructions



· **DE** Von der anderen Seite aus gesehen, können Sie auch sehen, dass der Rand der Gitteröffnung die Sicherheitsleiste nicht behindert. Sie können sich das Installationsvideo ansehen, indem Sie den Code scannen oder die folgende Seite besuchen:

www.omlet.de/anleitungen

· **FR** ... De l'autre côté, vous pouvez voir que l'entrée du poulailler ne bloque pas la barre de sécurité. Vous pouvez visionner une vidéo d'instructions en scannant le code ou en cliquant sur le lien ci-dessous:

www.omlet.fr/instructions

· **NL** ...Vanaf de andere kant bekeken, is zichtbaar dat de opening van het kippenhok de veiligheidssensor niet blokkeert. Scan de code om de installatievideo te bekijken of ga naar:

www.omlet.nl/gebruiksaanwijzing

· **IT** ...Visto dall'altra parte, potete verificare che l'apertura del pollaio non blocchi la barra di sicurezza. Potete guardare il video dell'installazione scansionando il codice o visitando:

www.omlet.it/istruzioni

· **SE** ...Om du tittar från den andra sidan kan du också se till att öppningen på höns huset inte är i vägen för säkerhetssensorn. Du kan titta på vår installationsvideo som visar exakt hur du ska göra antingen genom att skanna koden eller besöka:

www.omlet.se/bruksanvisning

· **DK** ...Set fra den anden side kan du også se, at høns husets åbning ikke sidder i vejen for sikkerhedssensoren. Du kan se installationsvideoen ved at scanne koden eller besøge:

www.omlet.dk/bruksanvisning

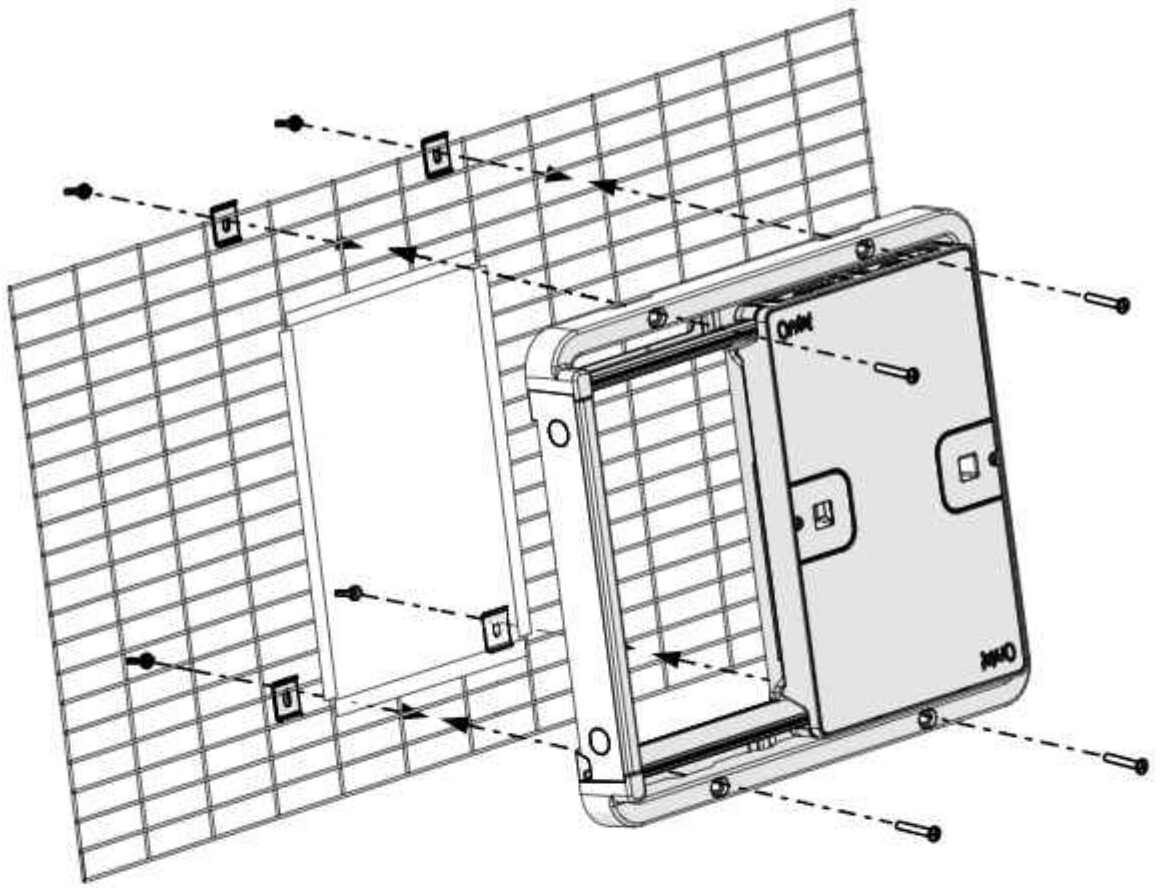
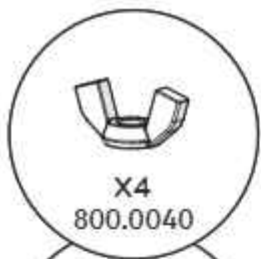

or
oder · ou · of · oppure · o · eller · lub

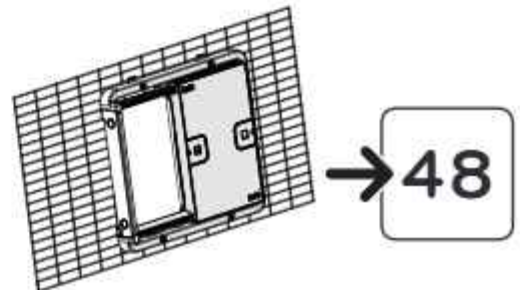
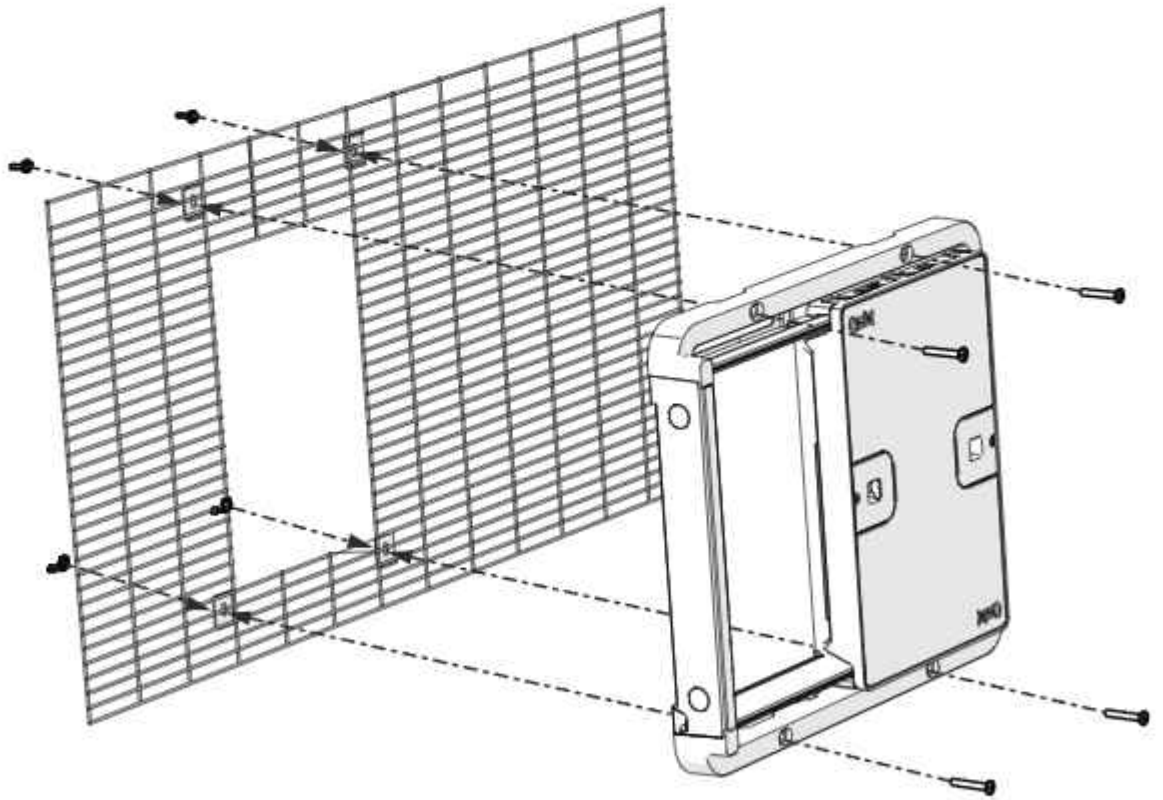

DE Anbringen des Türrahmens an Holz · FR Fixation du cadre sur un poutrelle en bois · NL Het deurframe bevestigen op hout · IT Come fissare il pannello del tunnel ad un pannello in legno · SE Montera ramen på trävirke · DK Montering af ramme på træ

You will need...

DE Das brauchen Sie... · FR Vous aurez besoin de... · NL Wat u nodig heeft... · IT Avrai bisogno... · SE Du behöver...
DK Du skal bruge...

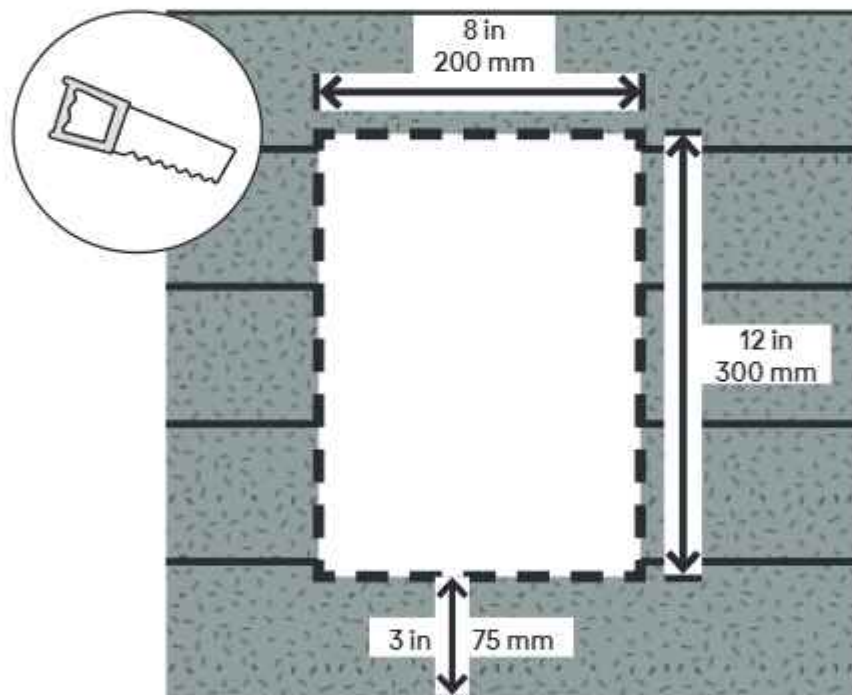
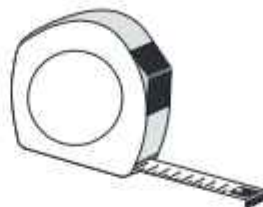
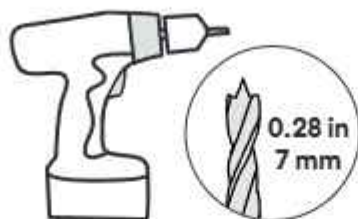
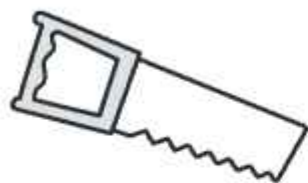

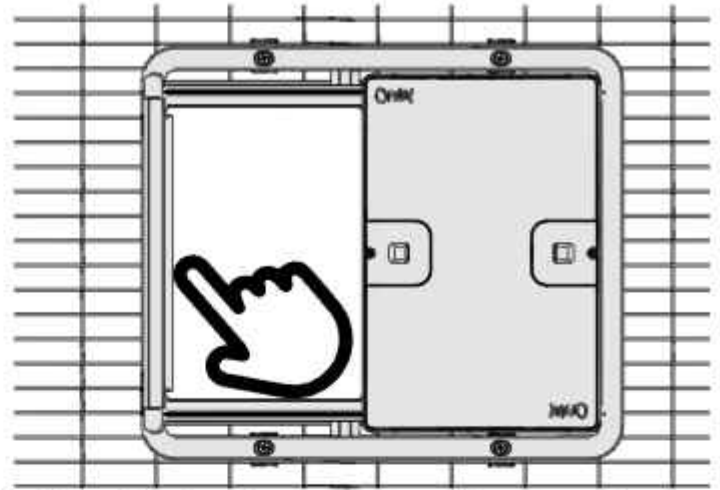
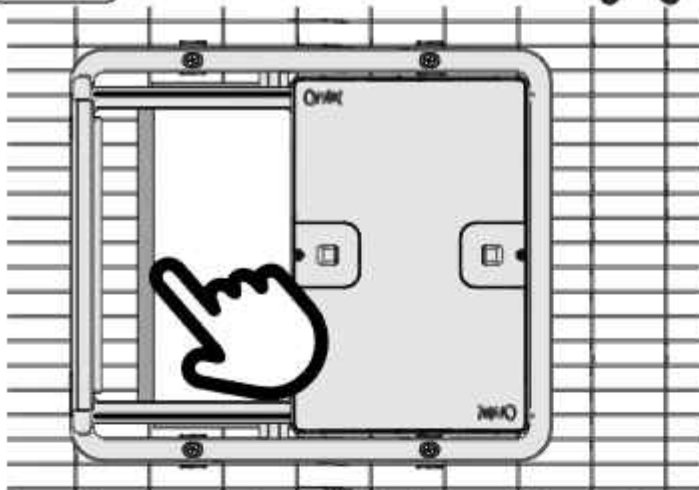

The safety sensor bar which detects if an object is blocking the door from closing will only work properly if the door is installed correctly. In the image to the left the opening of the coop is smaller than the opening of the Autodoor. In this case the Autodoor's safety sensor bar might not operate correctly. To solve this move the Autodoor so that the opening is set back from the edge of the safety bar by at least 0.2 in (5 mm) like in the picture to the right...

· **DE** Die Sicherheitssensorleiste, die erkennt, ob ein Gegenstand die Tür am Schließen hindert, funktioniert nur dann richtig, wenn die Tür korrekt eingebaut ist. Im linken Bild ist die Öffnung des Stalls kleiner als die Öffnung der Autodoor. In diesem Fall ist es möglich, dass die Sicherheitssensoren der Autodoor nicht richtig funktionieren. Um dies zu beheben, versetze die Autodoor so, dass die Öffnung mindestens 5 mm von der Kante der Sicherheitssensorleiste entfernt ist, wie im rechten Bild zu sehen ist ...

· **FR** La barre du capteur de sécurité, qui détecte l'éventuelle présence d'un objet entre elle et la porte pour l'empêcher de se fermer, ne fonctionnera que si la Porte Automatique est installée correctement. Sur l'image de gauche, l'ouverture du poulailler est plus petite que celle de la porte. Dans un cas comme celui-ci, il se peut que la barre du capteur ne fonctionne pas correctement. Pour y remédier, déplacez simplement la porte afin qu'il y ait au moins 5 mm entre l'ouverture du poulailler et la barre de sécurité (voir image de droite)...

· **NL** De veiligheidssensorbalk die detecteert of het sluiten van de deur geblokkeerd wordt door een object, werkt alleen goed als de deur correct is geïnstalleerd. In de afbeelding links is de opening van het kippenhok kleiner dan de opening van de Autodoor. In dit geval werkt de veiligheidssensorbalk van de Autodoor mogelijk niet correct. Om dit op te lossen verplaatst u de Autodoor dusdanig dat de opening minimaal 5 mm naar achteren ligt ten opzichte van de rand van de veiligheidssensorbalk, zoals op de afbeelding rechts...

· **IT** Il sensore di sicurezza che rileva se un oggetto sta ostruendo la porta e le impedisce la chiusura, funziona correttamente solo se la porta è stata installata in maniera adeguata. Nell'immagine a sinistra potete osservare che la porta del pollaio è più piccola dell'apertura dell'Autodoor. In questo caso il sensore di sicurezza dell'Autodoor non funzionerà correttamente. Potete facilmente risolvere il problema spostando l'Autodoor in modo che l'apertura sia distante dal bordo della barra del sensore di sicurezza almeno di 5 mm, come nel disegno a destra...

· **SE** Säkerhetssensorn som känner av om någonting blockerar dörren kommer bara fungera om dörren är installerad på rätt sätt. På bilden till vänster kan du se att öppningen på hönsuset är mindre än öppningen på Autodörren. Då finns en risk att säkerhetssensorn inte fungerar som den ska. Det är väldigt lätt att lösa genom att flytta Autodörren så att öppningen sitter åtminstone 5mm från kanten på säkerhetssensorn, som på bilden till höger...

· **DK** Sikkerhedssensorbjælken, der registrerer, om en genstand blokerer døren fra at lukke, fungerer kun korrekt, hvis døren er installeret korrekt. På billedet til venstre er åbningen af hønsesuset mindre end åbningen af Autodoor. I dette tilfælde fungerer Autodoors sikkerhedssensorbjælke muligvis ikke korrekt. For at løse dette problem skal du flytte Autodoor, så åbningen er sat mindst 5 mm tilbage fra kanten af sikkerhedsbjælken som på billedet til højre...

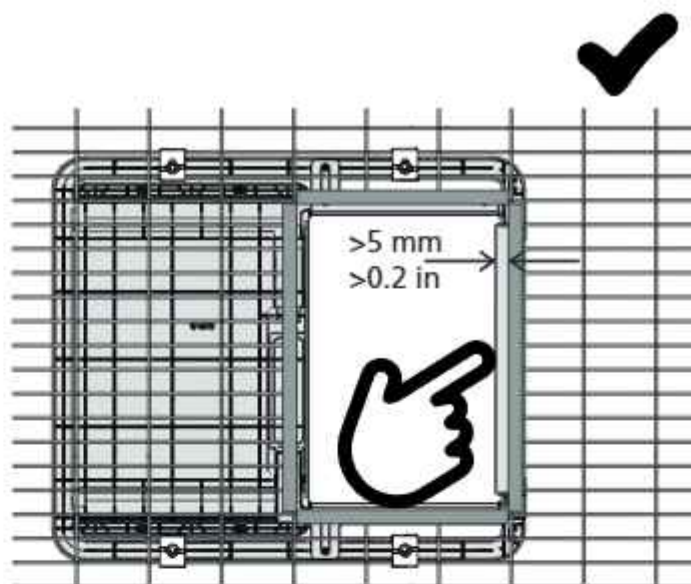
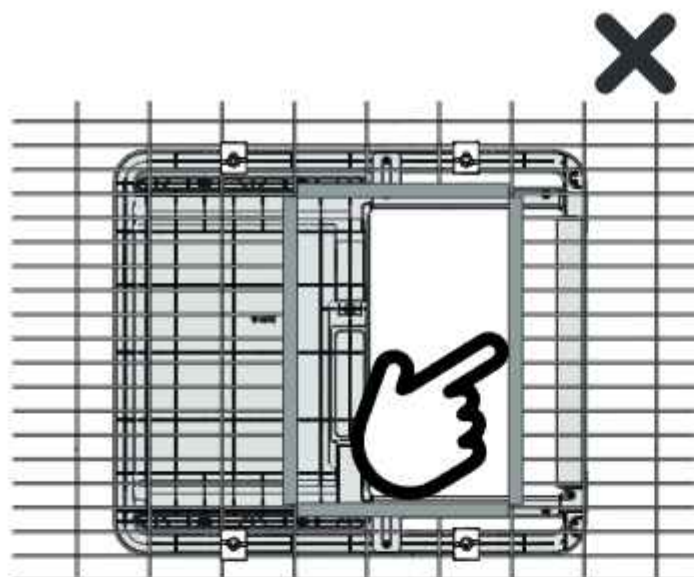

...Seen from the other side, you can also see the opening of the coop is not obstructing the safety bar. You can watch the installation video by scanning the code or visiting:
www.omlet.co.uk/instructions



· **DE** Von der anderen Seite aus gesehen, können Sie auch sehen, dass der Rand der Gitteröffnung die Sicherheitsleiste nicht behindert. Sie können sich das Installationsvideo ansehen, indem Sie den Code scannen oder die folgende Seite besuchen:

www.omlet.de/anleitungen

· **FR** ... De l'autre côté, vous pouvez voir que l'entrée du poulailler ne bloque pas la barre de sécurité. Vous pouvez visionner une vidéo d'instructions en scannant le code ou en cliquant sur le lien ci-dessous:

www.omlet.fr/instructions

· **NL** ...Vanaf de andere kant bekeken, is zichtbaar dat de opening van het kippenhok de veiligheidssensor niet blokkeert. Scan de code om de installatievideo te bekijken of ga naar:

www.omlet.nl/gebruiksaanwijzing

· **IT** ...Visto dall'altra parte, potete verificare che l'apertura del pollaio non blocchi la barra di sicurezza. Potete guardare il video dell'installazione scansionando il codice o visitando:

www.omlet.it/istruzioni

· **SE** ...Om du tittar från den andra sidan kan du också se till att öppningen på höns huset inte är i vägen för säkerhetssensorn. Du kan titta på vår installationsvideo som visar exakt hur du ska göra antingen genom att skanna koden eller besöka:

www.omlet.se/bruksanvisning

· **DK** ...Set fra den anden side kan du også se, at høns husets åbning ikke sidder i vejen for sikkerhedssensoren. Du kan se installationsvideoen ved at scanne koden eller besøge:

www.omlet.dk/bruksanvisning

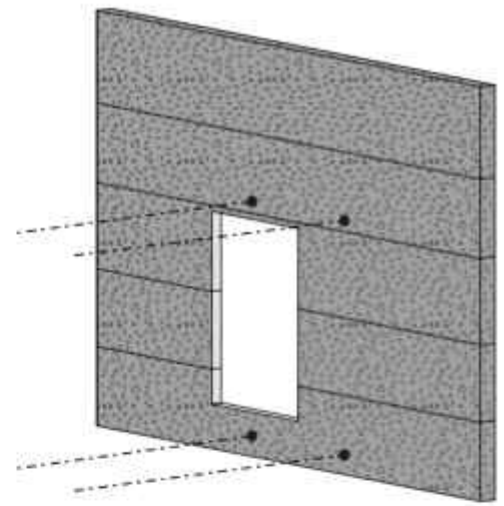
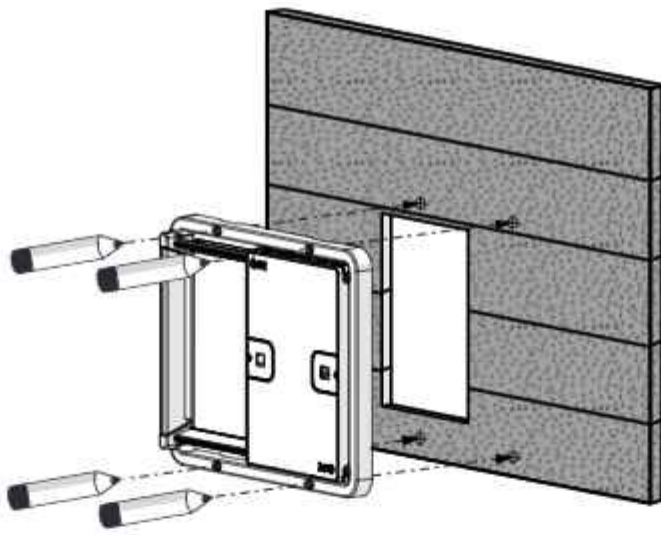

43

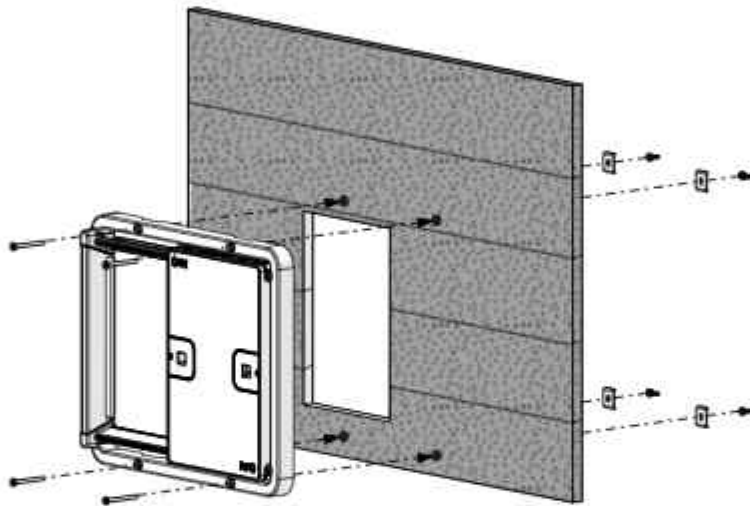

44

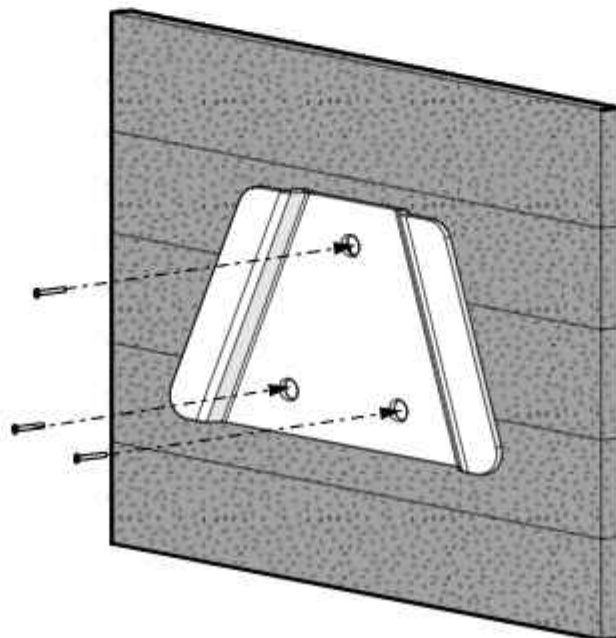

→ 48

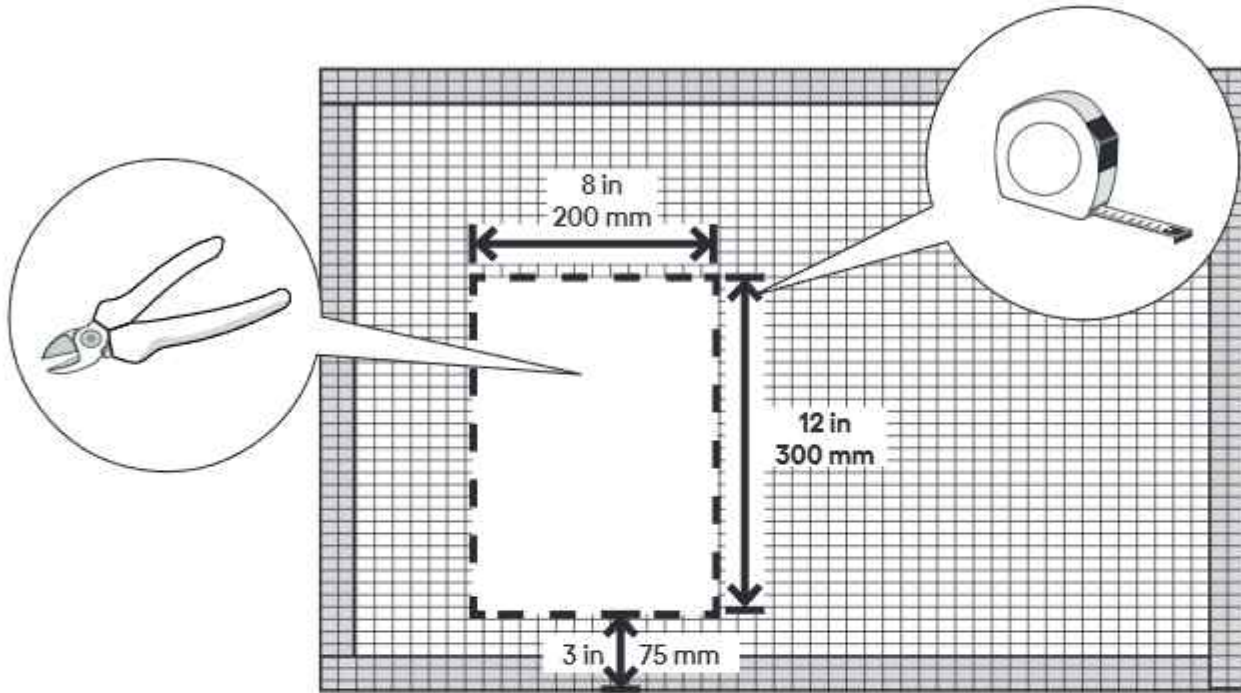
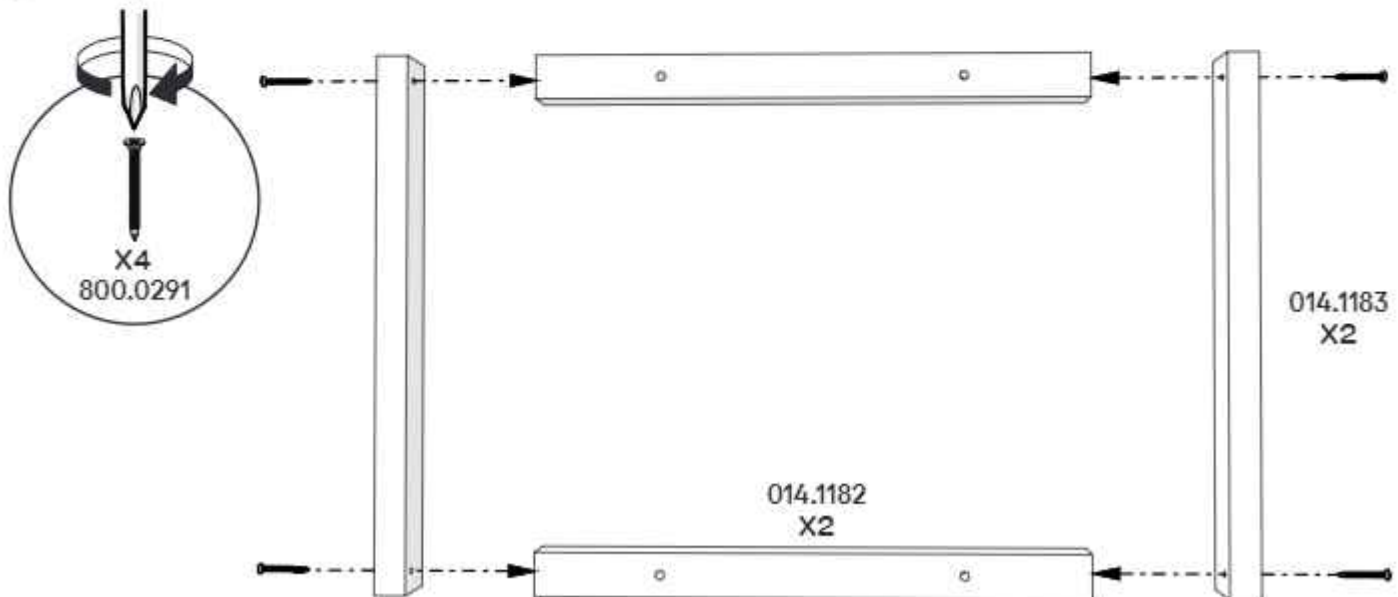
45**Attaching the Door Frame to non Omlet mesh****DE** Den Türrahmen an einem Gitter anbringen, das nicht von Omlet stammt**FR** Fixation du cadre sur un filet d'une autre marque que Omlet**NL** Het deurframe bevestigen op gaas, niet van Omlet afkomstig**IT** Come fissare il pannello del tunnel ad un pannello Shold eliminate on Omlet**SE** Montera ramen på nät som inte är från Omlet**DK** Montering af ramme på høsenet som ikke er fra Omlet**+ 014.0072: Auto Door Wooden Coop Mesh Mounting Kit****46**

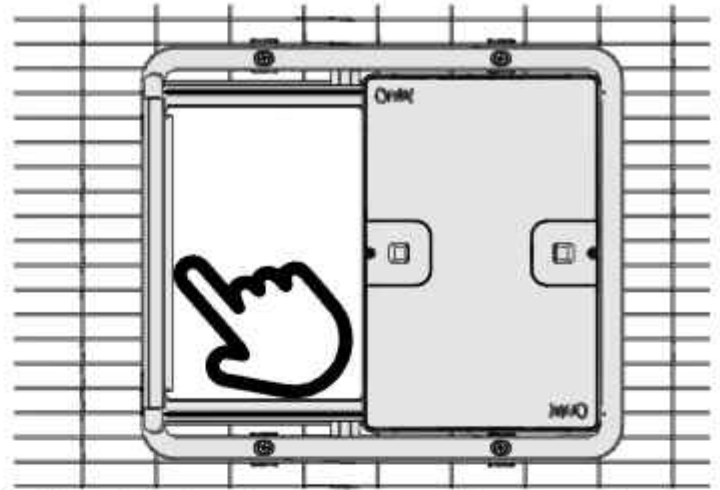
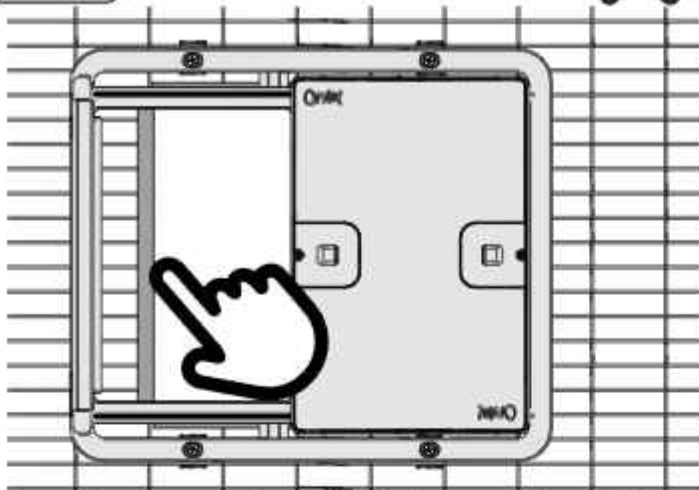

The safety sensor bar which detects if an object is blocking the door from closing will only work properly if the door is installed correctly. In the image to the left the opening of the coop is smaller than the opening of the Autodoor. In this case the Autodoor's safety sensor bar might not operate correctly. To solve this move the Autodoor so that the opening is set back from the edge of the safety bar by at least 0.2 in (5 mm) like in the picture to the right...

· **DE** Die Sicherheitssensorleiste, die erkennt, ob ein Gegenstand die Tür am Schließen hindert, funktioniert nur dann richtig, wenn die Tür korrekt eingebaut ist. Im linken Bild ist die Öffnung des Stalls kleiner als die Öffnung der Autodoor. In diesem Fall ist es möglich, dass die Sicherheitssensoren der Autodoor nicht richtig funktionieren. Um dies zu beheben, versetze die Autodoor so, dass die Öffnung mindestens 5 mm von der Kante der Sicherheitssensorleiste entfernt ist, wie im rechten Bild zu sehen ist ...

· **FR** La barre du capteur de sécurité, qui détecte l'éventuelle présence d'un objet entre elle et la porte pour l'empêcher de se fermer, ne fonctionnera que si la Porte Automatique est installée correctement. Sur l'image de gauche, l'ouverture du poulailler est plus petite que celle de la porte. Dans un cas comme celui-ci, il se peut que la barre du capteur ne fonctionne pas correctement. Pour y remédier, déplacez simplement la porte afin qu'il y ait au moins 5 mm entre l'ouverture du poulailler et la barre de sécurité (voir image de droite)...

· **NL** De veiligheidssensorbalk die detecteert of het sluiten van de deur geblokkeerd wordt door een object, werkt alleen goed als de deur correct is geïnstalleerd. In de afbeelding links is de opening van het kippenhok kleiner dan de opening van de Autodoor. In dit geval werkt de veiligheidssensorbalk van de Autodoor mogelijk niet correct. Om dit op te lossen verplaatst u de Autodoor dusdanig dat de opening minimaal 5 mm naar achteren ligt ten opzichte van de rand van de veiligheidssensorbalk, zoals op de afbeelding rechts...

· **IT** Il sensore di sicurezza che rileva se un oggetto sta ostruendo la porta e le impedisce la chiusura, funziona correttamente solo se la porta è stata installata in maniera adeguata. Nell'immagine a sinistra potete osservare che la porta del pollaio è più piccola dell'apertura dell'Autodoor. In questo caso il sensore di sicurezza dell'Autodoor non funzionerà correttamente. Potete facilmente risolvere il problema spostando l'Autodoor in modo che l'apertura sia distante dal bordo della barra del sensore di sicurezza almeno di 5 mm, come nel disegno a destra...

· **SE** Säkerhetssensorn som känner av om någonting blockerar dörren kommer bara fungera om dörren är installerad på rätt sätt. På bilden till vänster kan du se att öppningen på hönsuset är mindre än öppningen på Autodörren. Då finns en risk att säkerhetssensorn inte fungerar som den ska. Det är väldigt lätt att lösa genom att flytta Autodörren så att öppningen sitter åtminstone 5mm från kanten på säkerhetssensorn, som på bilden till höger...

· **DK** Sikkerhedssensorbjælken, der registrerer, om en genstand blokerer døren fra at lukke, fungerer kun korrekt, hvis døren er installeret korrekt. På billedet til venstre er åbningen af hønsesuset mindre end åbningen af Autodoor. I dette tilfælde fungerer Autodoors sikkerhedssensorbjælke muligvis ikke korrekt. For at løse dette problem skal du flytte Autodoor, så åbningen er sat mindst 5 mm tilbage fra kanten af sikkerhedsbjælken som på billedet til højre...

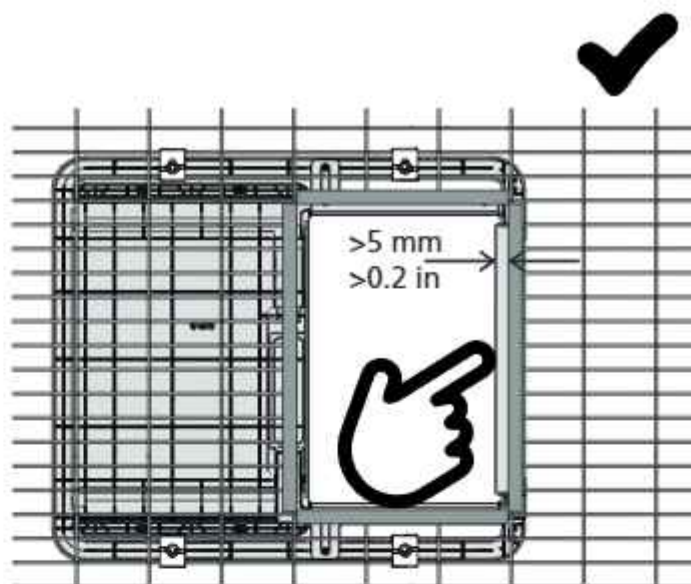
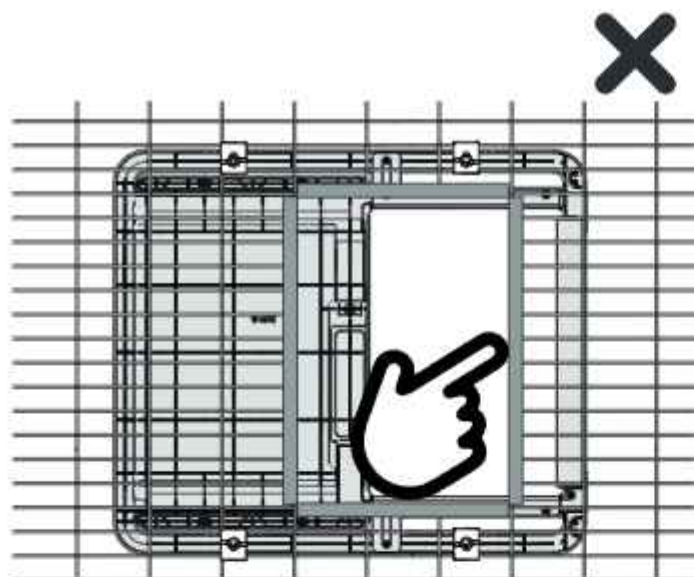

...Seen from the other side, you can also see the opening of the coop is not obstructing the safety bar. You can watch the installation video by scanning the code or visiting:
www.omlet.co.uk/instructions



· **DE** Von der anderen Seite aus gesehen, können Sie auch sehen, dass der Rand der Gitteröffnung die Sicherheitsleiste nicht behindert. Sie können sich das Installationsvideo ansehen, indem Sie den Code scannen oder die folgende Seite besuchen:

www.omlet.de/anleitungen

· **FR** ... De l'autre côté, vous pouvez voir que l'entrée du poulailler ne bloque pas la barre de sécurité. Vous pouvez visionner une vidéo d'instructions en scannant le code ou en cliquant sur le lien ci-dessous:

www.omlet.fr/instructions

· **NL** ...Vanaf de andere kant bekeken, is zichtbaar dat de opening van het kippenhok de veiligheidssensor niet blokkeert. Scan de code om de installatievideo te bekijken of ga naar:

www.omlet.nl/gebruiksaanwijzing

· **IT** ...Visto dall'altra parte, potete verificare che l'apertura del pollaio non blocchi la barra di sicurezza. Potete guardare il video dell'installazione scansionando il codice o visitando:

www.omlet.it/istruzioni

· **SE** ...Om du tittar från den andra sidan kan du också se till att öppningen på höns huset inte är i vägen för säkerhetssensorn. Du kan titta på vår installationsvideo som visar exakt hur du ska göra antingen genom att skanna koden eller besöka:

www.omlet.se/bruksanvisning

· **DK** ...Set fra den anden side kan du også se, at høns husets åbning ikke sidder i vejen for sikkerhedssensoren. Du kan se installationsvideoen ved at scanne koden eller besøge:

www.omlet.dk/bruksanvisning

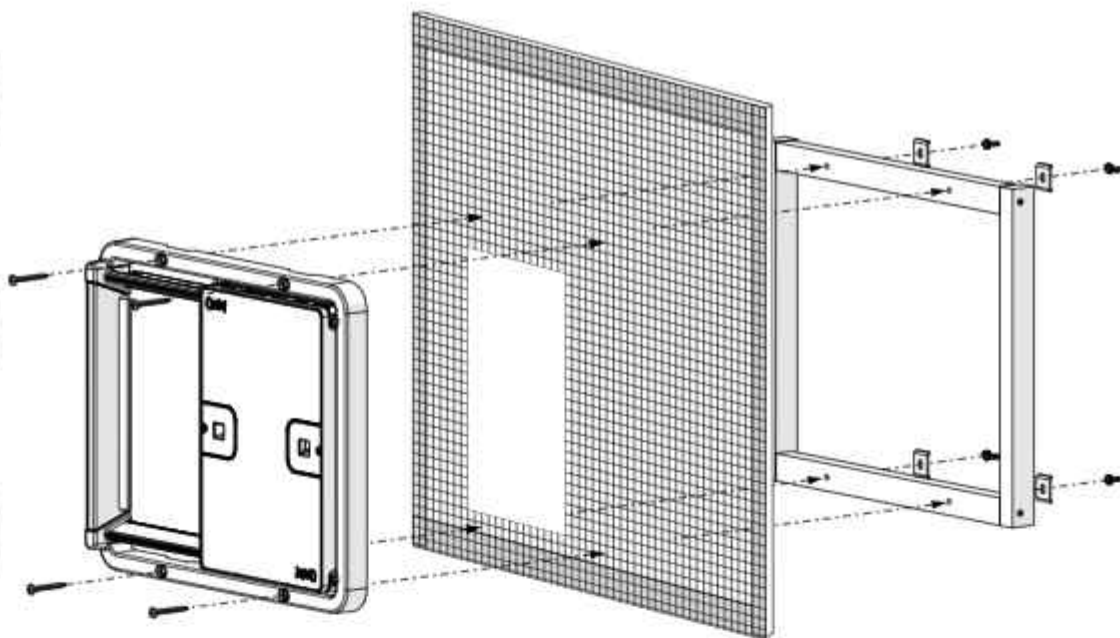
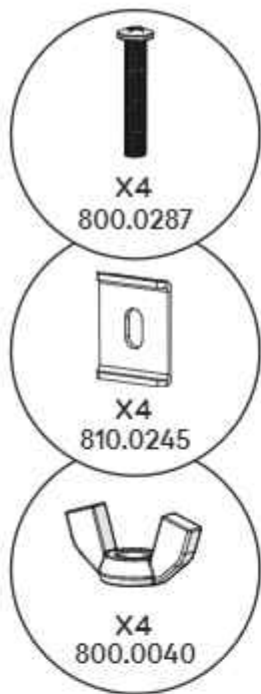

Assemble the control panel

DE Die Steuerungseinheit anbringen · FR Assemblage du tableau de bord · NL Het bedieningspaneel monteren
IT Assemblare il Pannello di Controllo · SE Sätt ihop kontrollpanelen · DK Saml kontrolpanelet

48

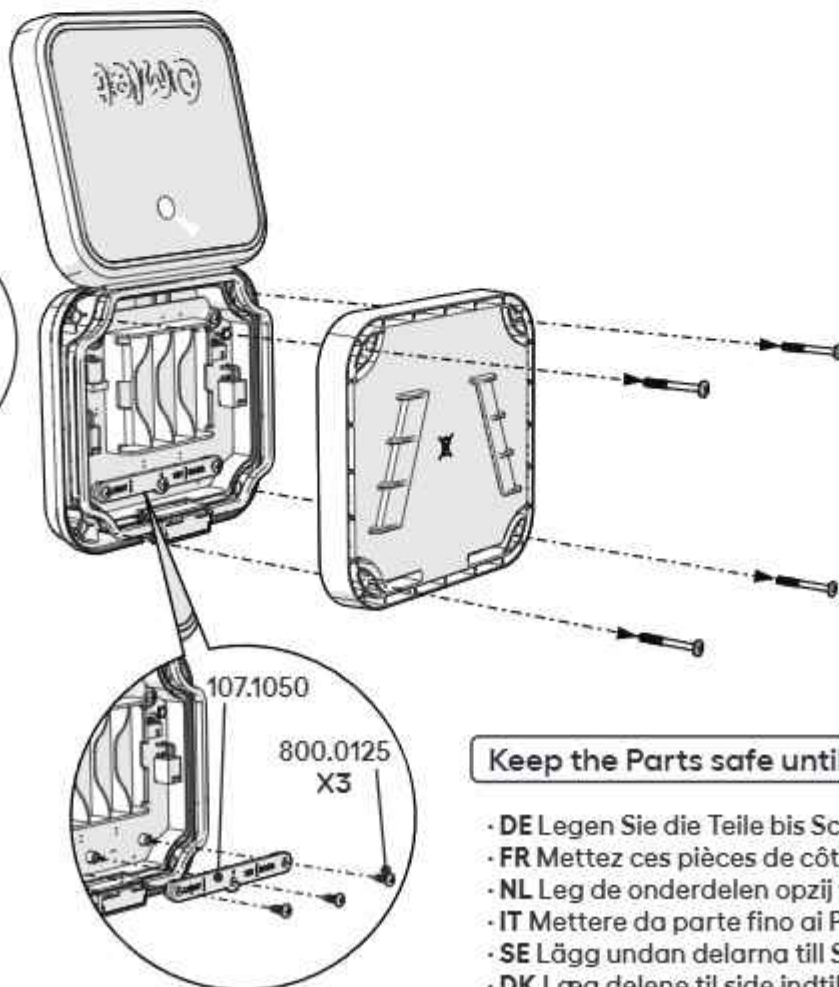

Keep the Parts safe until Steps 50-51



- DE Legen Sie die Teile bis Schritte 50 & 51 beiseite
- FR Mettez ces pièces de côté pour les étapes 50-51
- NL Leg de onderdelen opzij tot stap 50-51
- IT Mettere da parte fino ai Punti 50-51
- SE Lägg undan delarna till Steg 50-51
- DK Læg delene til side indtil trin 50-51

If connecting to Wi-Fi then use Power Adaptor.

If not connecting to Wi-Fi then you have the option to use batteries or power supply. Do not use both simultaneously.



- DE Wenn Sie eine WLAN-Verbindung herstellen wollen, verwenden Sie das Netzteil. Wenn Sie keine WLAN-Verbindung herstellen, haben Sie die Möglichkeit, Batterien oder das Netzteil zu verwenden. Benutzen Sie nicht beides gleichzeitig.
- FR Si vous vous connectez au Wi-Fi, utilisez l'adaptateur d'alimentation. Si l'appareil n'est pas connecté au Wi-Fi, utilisez des piles ou un adaptateur d'alimentation. N'utilisez pas les deux simultanément.
- NL Als u verbinding maakt met Wi-Fi, gebruik dan een voedingsadapter. Als u geen verbinding maakt met Wi-Fi, heeft u de mogelijkheid om batterijen of een voeding te gebruiken. Gebruik beide niet tegelijkertijd.
- IT Se ti connetti al Wi-Fi, utilizza l'alimentatore. Se non ti connetti al Wi-Fi, hai la possibilità di utilizzare batterie o alimentatore. Non utilizzare entrambi contemporaneamente.
- SE Om du kopplar till wifi, använd strömadapter. Om du inte kopplar till wifi kan du använda batterier eller strömadapter. Använd inte båda samtidigt.
- DK Hvis du opretter forbindelse til Wi-Fi, skal du bruge strömadapteren. Hvis du ikke opretter forbindelse til Wi-Fi, har du mulighed for at bruge batterier eller strömforsyning. Brug ikke begge dele samtidigt.

Omlet Power Adaptor supplied separately



- DE Omlet Netzteil separat erhältlich
- FR Omlet Adaptateur secteur fourni séparément
- NL Omlet Stroomadapter apart geleverd
- IT Omlet Adattatore di alimentazione fornito separatamente
- SE Omlet Strömadapter medföljer separat
- DK Omlet Strömadapter medfølger separat

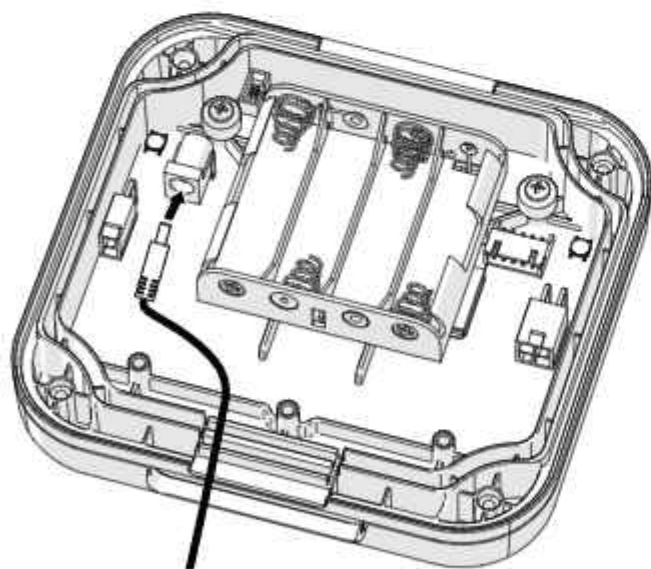

Omlet 12V Power
Supply
X1

or
oder · ou · of ·
oppure o · eller
· lub

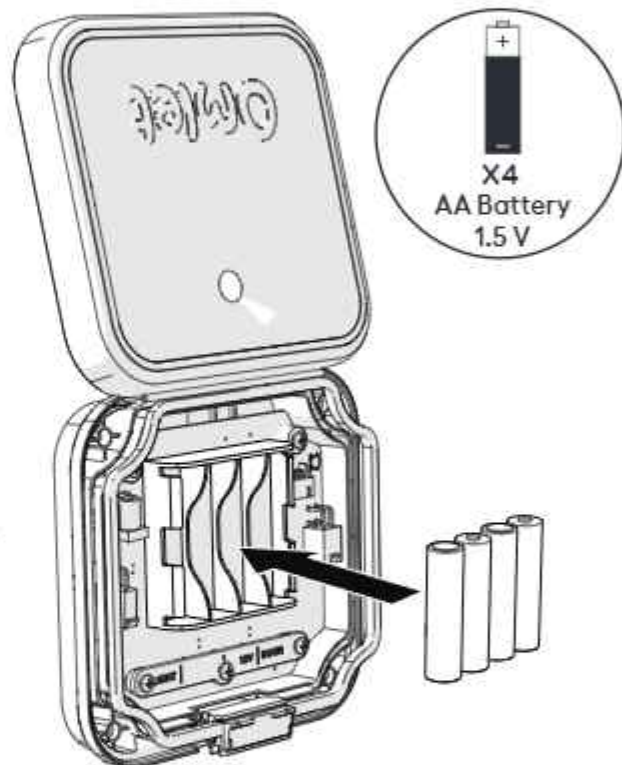

Check your batteries every 3 months. Always use 4 batteries of the same brand and energy level.



- DE Überprüfen Sie Ihre Batterien alle 3 Monate. Verwenden Sie immer 4 Batterien der gleichen Marke und des gleichen Energieniveaus.
- FR Vérifiez les piles tous les 3 mois. Utilisez toujours 4 piles de même marque et de même niveau d'énergie.
- NL Controleer de batterijen elke drie maanden. Gebruik vier batterijen van hetzelfde merk en voltage.
- IT Controllate le batterie ogni 3 mesi. Usate sempre 4 batterie della stessa marca e di livello energetico.
- SE Kontrollera batterierna var tredje månad. Använd alltid fyra batterier av samma märke och energinivå.
- DK Tjek dine batterier hver 3. måned. Brug altid 4 batterier af samme mærke og energiniveau.

50

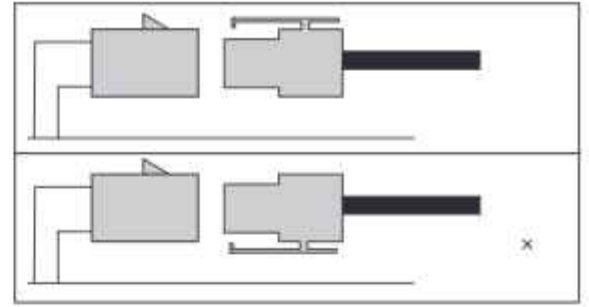
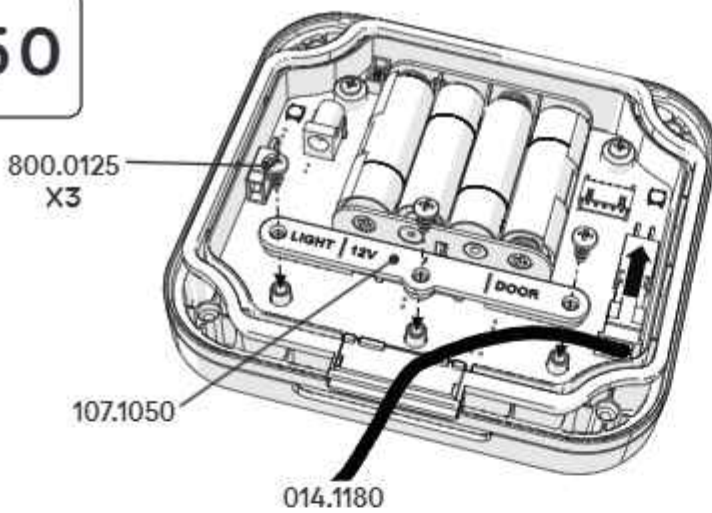

If you have a Coop Light, refer to Coop Light instruction manual now or scan the code or visit: www.omlet.co.uk/instructions



- **DE** Wenn Sie ein Stall-Licht besitzen, folgen Sie nun bitte der Anleitung für das Stall-Licht oder scannen Sie den Code bzw. besuchen Sie: www.omlet.de/anleitungen
- **FR** Si vous disposez d'une veilleuse, veuillez consulter le manuel d'instructions de la veilleuse. Vous pouvez aussi scanner le code ou cliquer sur le lien ci-dessous : www.omlet.fr/instructions
- **NL** Indien u een kippenhoklamp heeft, raadpleeg dan de gebruiksaanwijzing van de kippenhoklamp. U kan ook de code scannen of deze site bezoeken: www.omlet.nl/gebruiksaanwijzing
- **IT** Se avete una Luce per pollai, fate riferimento al manuale d'istruzioni per Luce da pollai o scansionate il codice o visitate: www.omlet.it/istruzioni
- **SE** Om du har en hönslyslampa hittar du instruktionerna i bruksanvisningen som tillhör den. Du kan också skanna koden eller besöka: www.omlet.se/bruksanvisning
- **DK** Hvis du har en hønselyslampe så se venligst brugsanvisningen til denne nu, scan koden eller besøg: www.omlet.dk/brugsanvisning

51

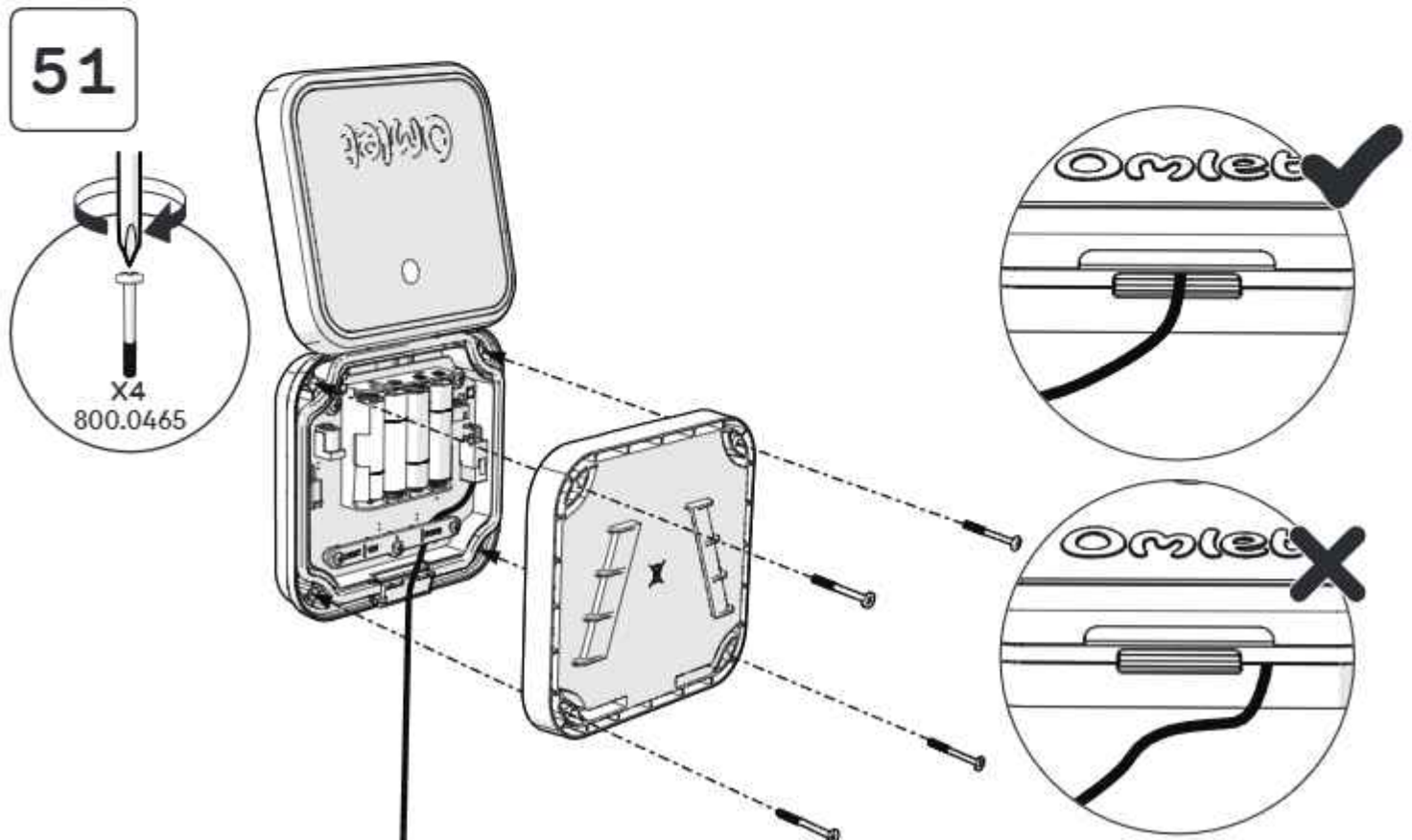

Mount the Control Panel so that the Light Sensor can receive natural light throughout the day.

- **DE** Bringen Sie die Steuerungseinheit so an, dass der Lichtsensor den Tag über natürliches Licht empfangen kann.
- **FR** Lorsque vous fixez le tableau de bord, assurez-vous que le capteur soit bien exposé à la lumière.
- **NL** Plaats het bedieningspaneel zo dat de lichtsensor gedurende de dag natuurlijk licht kan opvangen.
- **IT** Montare il Pannello di Controllo facendo attenzione che il Sensore di Luminosità riceva sempre luce naturale durante tutto il giorno.
- **SE** Sätt kontrollpanelen så att ljussensorn kan få naturligt ljus under hela dagen.
- **DK** Monter kontrolpanelet, så lyssensoren kan modtage dagslys hele dagen.



Light Sensor

- **DE** Lichtsensor
- **FR** Capteur de lumière
- **NL** Lichtsensor
- **IT** Sensore Luminosità
- **SE** Ljussensor
- **DK** Lyssensor

Do not put the Control Panel under cover. Be aware, weather conditions, orientation, seasonal light levels and artificial lights around the house and garden can also significantly affect the light

- **DE** Decken Sie die Steuerungseinheit nicht ab. Beachten Sie auch, dass die Wetterbedingungen, die Ausrichtung, die jahreszeitlich bedingten Lichtverhältnisse und künstliche Beleuchtung am Haus und im Garten die Lichtanzeige erheblich beeinflussen können.
- **FR** Ne recouvrez jamais le tableau de bord. Attention : l'orientation du capteur et les conditions climatiques peuvent grandement affecter le capteur de lumière.
- **NL** Bedek het bedieningspaneel niet. Houd er rekening mee dat ook weersomstandigheden, oriëntatie, verandering van het lichtniveau per seizoen en kunstlicht rond het huis en in de tuin de lichtsensor kunnen beïnvloeden.
- **IT** Non coprite mai il pannello di controllo. Fate attenzione perché le condizioni meteo, l'orientamento, i livelli di luce stagionali e le luci artificiali vicino a casa e al giardino possono compromettere la lettura della luce.
- **SE** Sätt inte kontrollpanelen på en täckt plats. Uppmärksamma att väder, placering, olika ljusnivåer beroende på säsong och ljus från andra ljuskällor i höns huset och trädgården också märkbart kan påverka avläsningen av ljuset.
- **DK** Undlad at sætte kontrolpanelet på et overdækket område. Vær opmærksom på at vejrforhold, orientering, årstidernes varierende lys og kunstig belysning også kan påvirke lysmålingen betydeligt.

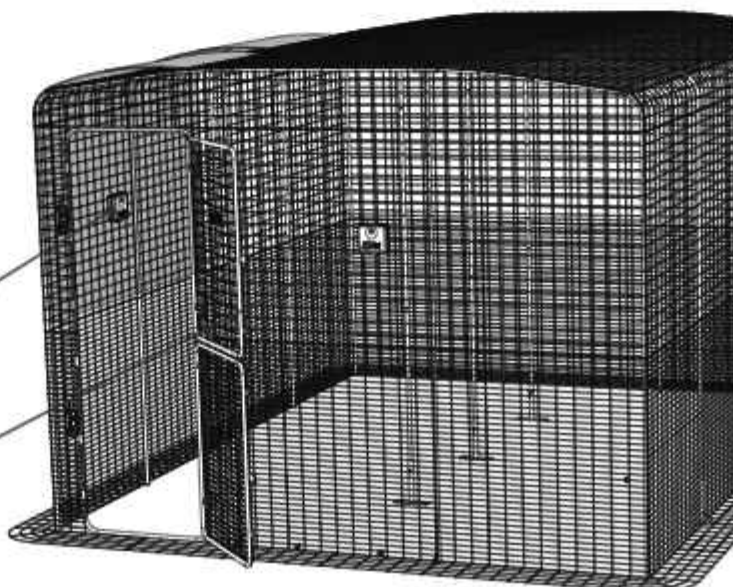
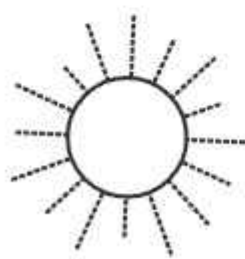

53

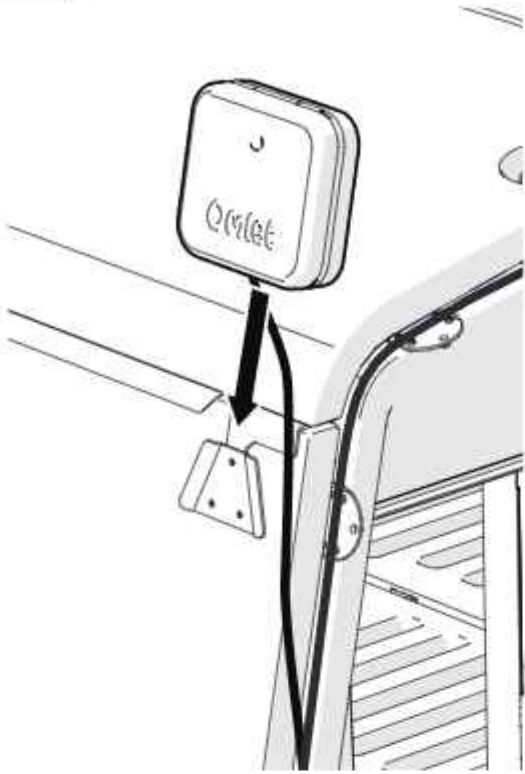

or
oder · ou · of · oppure
o · eller · lub

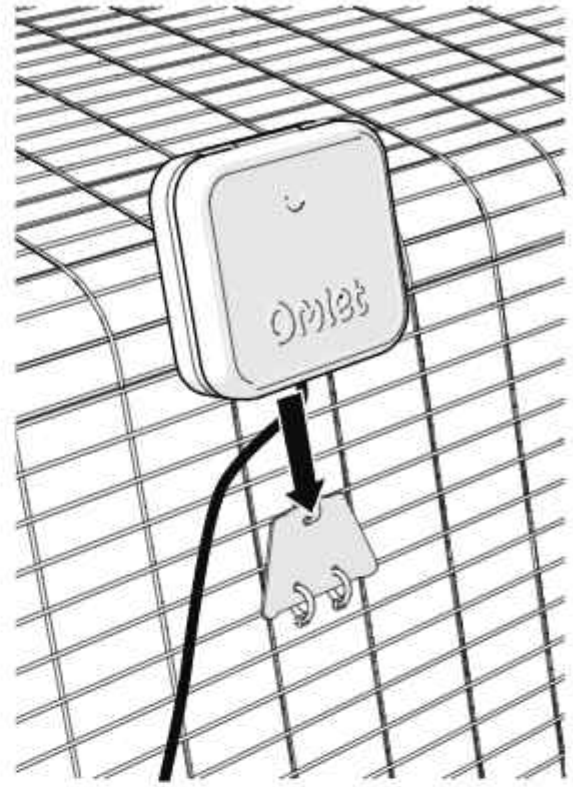

54

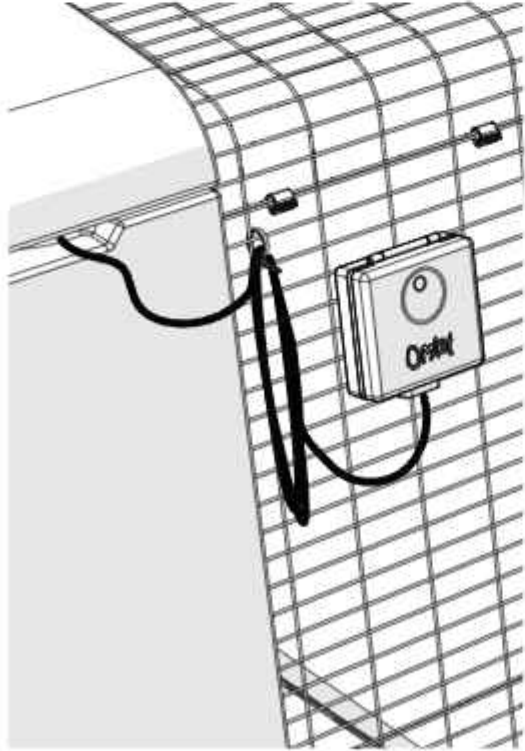
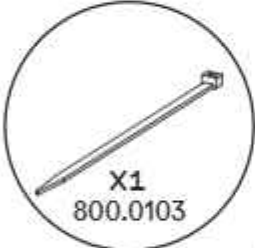

or
oder · ou · of · oppure
o · eller · lub

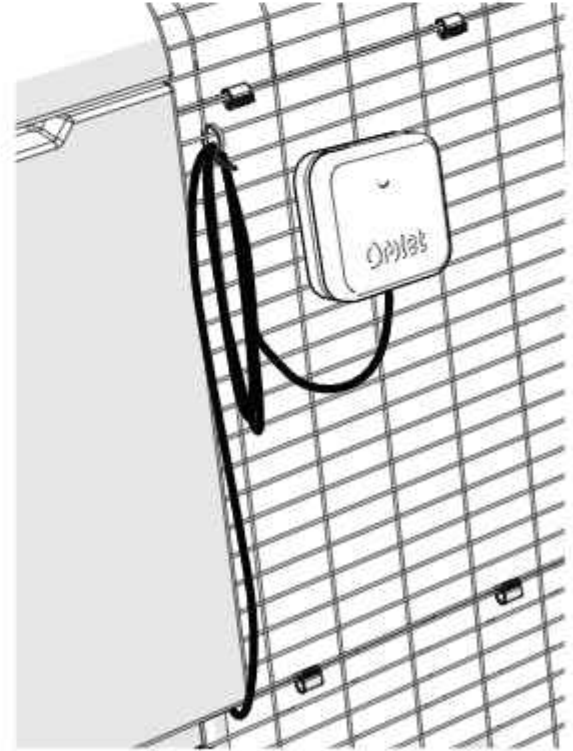

Quickstart Guide

DE Schnellstart-Anleitung · FR Bien démarrer avec la Porte Automatique Omlet · NL Snelstart handleiding · IT Guida Rapida · SE Snabbguide · DK Hurtig startvejledning

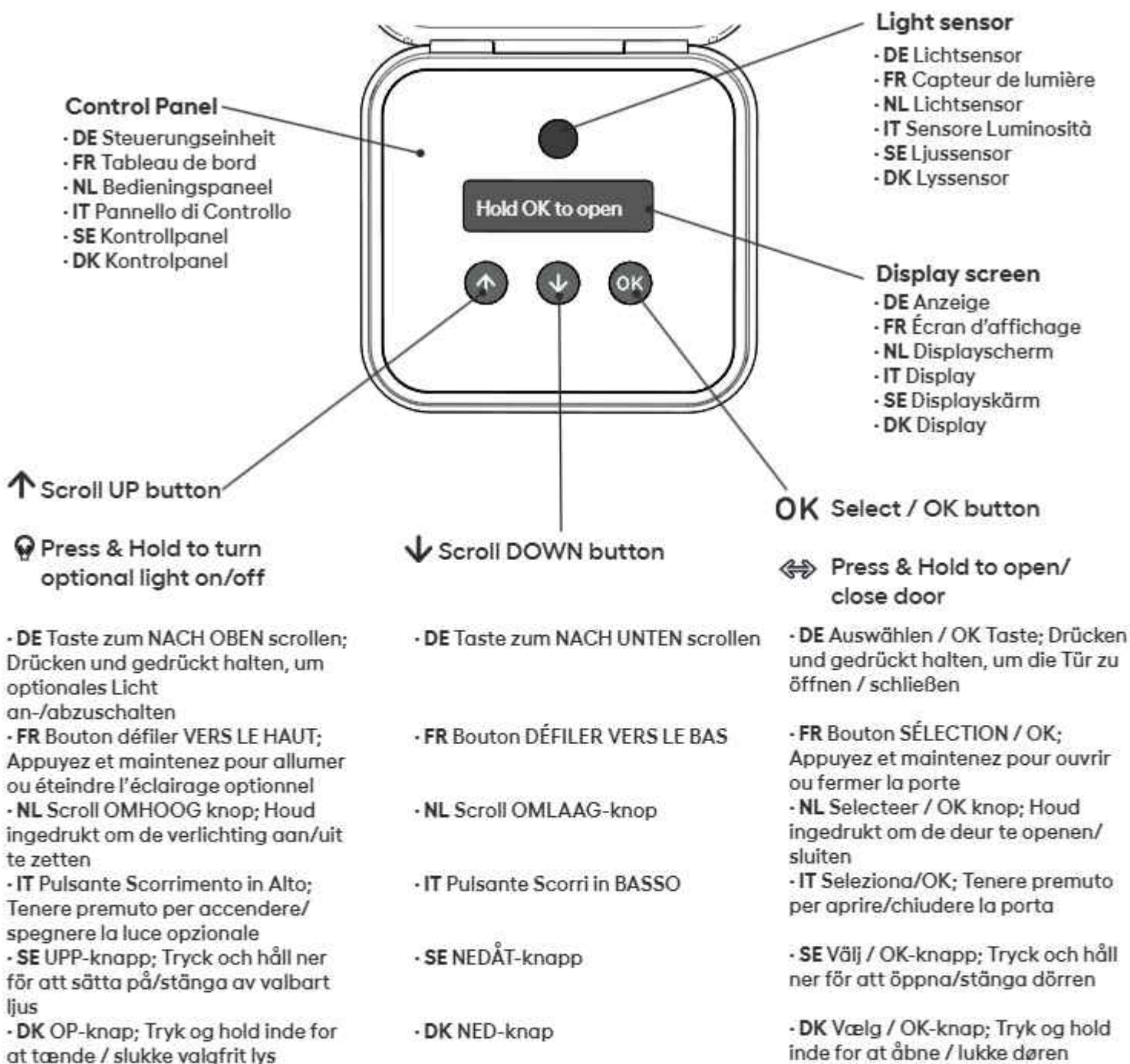

55

Controlling your Auto Door

DE Steuerung Ihrer Automatischen Tür · FR Contrôler votre porte automatique · NL Het bedienen van uw automatische deur · IT Controllare la tua porta automatica · SE Använd din autodörr · DK Styring af din automatiske dør

EN	DE	FR	NL	IT	SE	DK
↓	↓	↓	↓	↓	↓	↓
page	Seite	page	bladzijde	pagina	sida	side
49	55	61	67	73	80	85

56 Calibration

When you plug your Autodoor in for the first time, it will need to detect the door position. Press & Hold **OK** button.

The Autodoor will automatically calibrate itself by sliding the door once in each direction. Please ensure the Autodoor is not blocked during calibration.

During Calibration the control panel will read:

Calibrating...

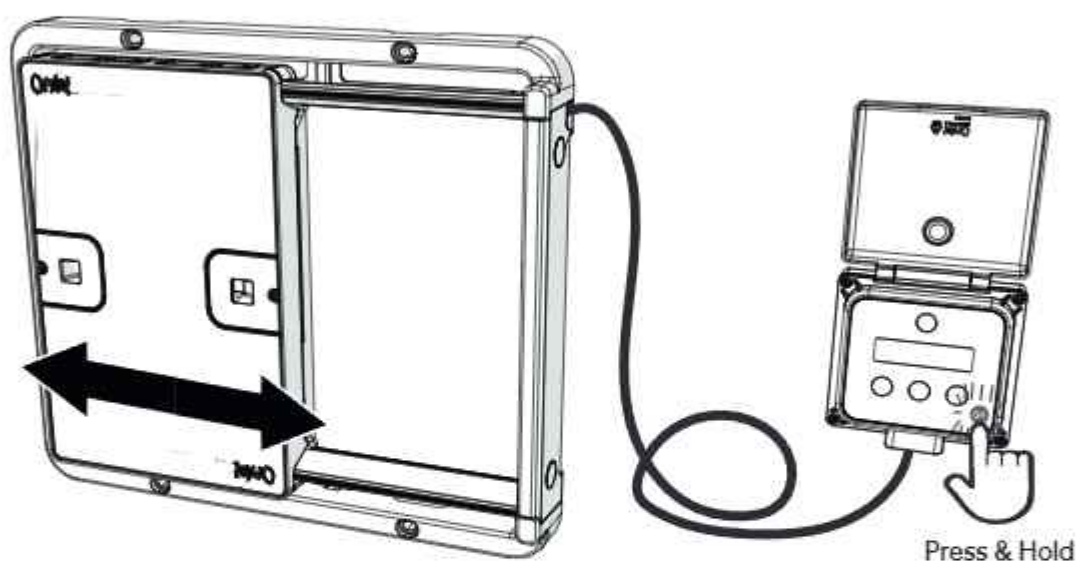

57 Optional: Change Language

1. Press the **↓** button to scroll through the menu until you reach this screen:

Language: En

2. Press & Hold **OK** to enable changing the language. The current language will flash

Language: **En**

3. Use **↑** or **↓** to scroll through the languages until you reach the desired language

Language: **En**

4. Press and hold **OK** to confirm the language update

--Saved--

The Automatic Door has 3 modes:

• **MANUAL** - The door will open and close if you Press & Hold button.

OK

→ 59

• **TIME** - You can set the Autodoor to open and close at specific times of the day.

→ 60

• **LIGHT** - This is the default mode. The Autodoor will open using the light sensor.

→ 61

Press any of the three buttons



and the screen will read:

Hold to Open

or

Hold to Close

Hold the **OK** button to either open or close the door.

To proceed through the menu press



to scroll up & down through the menu items.

In the Manual Mode menu you see the following:

Hold to Open

This displays the battery charge level.

Battery: 100%

This displays the current Mode setting.

1. Mode: Manual

This gives you the option to reset the Control Pack back to its default settings following any changes you make.

5. Factory Reset



The Automatic Door uses the 24-hour clock, to prevent any ambiguity. The time will reset when batteries are taken out. Make sure to update the current time after every battery exchange.



Setting the Mode

1. Press  for a short time to scroll through the options until you reach the mode

1. Mode: Manual

2. Press & Hold  to enable changing the value. The current mode will flash

1. Mode:  Manual

3. Use   to scroll through the modes

1. Mode:  Manual

1. Mode:  Time

4. Press & Hold  to confirm the value change

--Saved--

Setting the Current Time

1. Press  for a short time to scroll through the options until you reach the mode menu item

2. Time: 14:23

2. Press & Hold  until the minutes begin to flash

2. Time: 14:  23

3. Press  or  to set the minutes

2. Time: 14:  05

4. Press  to switch to hours which will flash to confirm they are selected

2. Time:  14:05

5. Press  or  to set the hours

2. Time:  18:05

6. Press & Hold  to confirm. The display will read -saved-

--Saved--

Setting the Opening Time

1. Press  for a short time to scroll through the options until you reach the display on the right

3. Open @ 01:00

2. Press & Hold  until the minutes begin to flash

3. Open @ 01:~~00~~

3. Press  or  to set the minutes

3. Open @ 01:~~30~~

4. Press  to switch to hours which will flash to confirm they are selected

3. Open @ ~~01~~:30

5. Press  or  to set the hours

3. Open @ ~~08~~:30

6. Press & Hold  to confirm.

--Saved--

Setting the Closing Time

1. Press  for a short time to scroll through the options until you reach the display on the right

4. Close @ 01:00

2. Press & Hold  until the minutes begin to flash

4. Close @ 01:~~00~~

3. Press  or  to set the minutes

4. Close @ 01:~~15~~

4. Press  to switch to hours which will flash to confirm they are selected

4. Close @ ~~01~~:15

5. Press  or  to set the hours

4. Close @ ~~19~~:15

6. Press & Hold  to confirm.

--Saved--

61

Light Mode



If the light level where the control panel is located changes frequently (busy neighbourhood) light mode may not function as expected - please switch to Time Mode

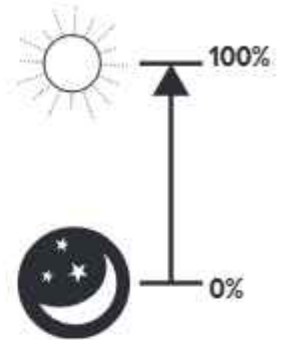



Setting the Mode

1. Press  for a short time to scroll through the options until you reach the mode

1. Mode: Manual

2. Press & Hold  to enable changing the value
The current mode will flash

1. Mode: Manual

3. Use   to scroll through the modes

1. Mode: Manual

4. Press & Hold  to confirm the value change

1. Mode: Light

--Saved--

Setting the Light Opening Level



The door opening light level should be set to a higher percentage than the door closing light level. The two values should at least be 10% apart from each other. We recommend starting with 13 and 3, then adjust to suit as the location of the coop can effect the light levels. Adjustments may be needed with the change of seasons.

1. Press  for a short time to scroll through the options until you reach the display on the right

3. Open @ 27

2. Press & Hold  until the numbers begin to flash

3. Open @ 27

3. Press  or  to set the level

3. Open @ 13

4. Press & Hold  to confirm

--Saved--

Setting the Light Closing Level

1. Press  for a short time to scroll through the options until you reach the display on the right
2. Press & Hold  until the numbers begin to flash
3. Press  or  to set the level
4. Press & Hold  to confirm.

4. Close @ 6

4. Close @ 

4. Close @ 

--Saved--

Setting the Open Delay



By default, the Auto Door has a factory delay set at 20 minutes after the light reaches the required level. You cannot go below 20 minutes and can only manually set additional delay minutes. This is in order to prevent any accidental opening or closing of the door when the light level changes for short periods of time, e.g. if a car drove past with headlights on.

1. Press  for a short time to scroll through the options until you reach the display on the right
2. Press & Hold  until the numbers begin to flash
3. Press  or  to set the minutes
4. Press & Hold  to confirm.

5. Open Delay 0m

5. Open Delay 



5. Open Delay 

--Saved--

Setting the Close Delay



Same principle as at opening delay - See above.

1. Press  for a short time to scroll through the options until you reach the display on the right
2. Press & Hold  until the numbers begin to flash
3. Press  or  to set the minutes
4. Press & Hold  to confirm.

6. Close Delay 0m

6. Close Delay 

6. Close Delay 

--Saved--

56

Kalibration

Wenn Sie die Automatische Tür zum ersten Mal verwenden, muss zunächst die Position der Tür ermittelt werden. Drücken und halten Sie dazu die **OK** Taste gedrückt.

Die Automatische Tür wird sich selbst einstellen, indem Sie sich einmal in jede Richtung bewegt. Bitte stellen Sie sicher, dass die Tür während dieses Vorgangs nicht blockiert ist.

Während der Kalibrierung wird auf dem Bedienfeld folgendes angezeigt:

Calibrating...

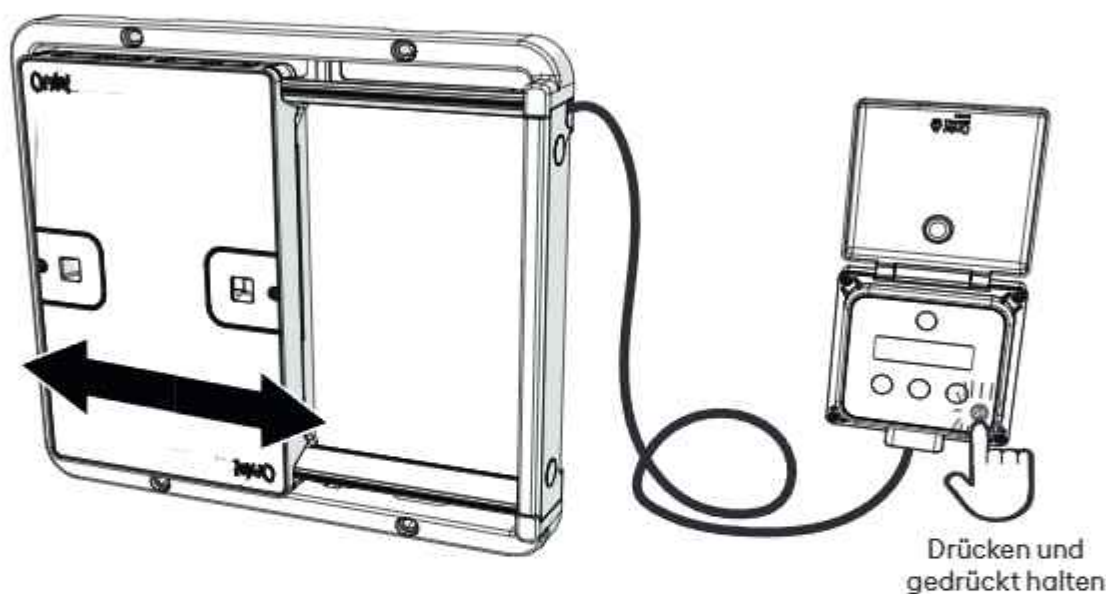

Drücken und gedrückt halten

57

Sprache ändern

1. Drücken Sie die Taste , um durch das Menü zu scrollen, bis Sie diesen Bildschirm erreichen:

Language: En

2. Drücken und Halten Sie **OK**, um die Änderung der Sprache zu ermöglichen. Die aktuelle Sprache wird blinken.

Language:  En

3. Scrollen Sie mit  oder  durch die Sprachen, bis Sie die gewünschte Sprache erreicht haben.

Sprache:  De

4. Drücken und Halten Sie **OK**, um die Aktualisierung der Sprache zu bestätigen.

--Gespeichert--



Die Automatische Tür kann in drei unterschiedlichen Modi verwendet werden:

- **MANUELL** - Die Tür öffnet und schließt sich, wenn Sie den  Knopf drücken und gedrückt halten.
- **ZEIT** - Sie können die Automatische Tür so einstellen, dass sie sich zu bestimmten Zeiten öffnet und schließt.
- **LICHT** - Das ist der Standardmodus. Die Automatische Tür öffnet und schließt sich mittels des integrierten Lichtsensors.

→ 59

→ 60

→ 61



Drücken Sie einen der drei Knöpfe   , und auf der Anzeige wird zu lesen sein:

Halten -> Schließt

oder

Halten -> Öffnet

Halten Sie die  Taste gedrückt, um die Tür zu öffnen oder zu schließen.

Um durch das Menü zu scrollen, verwenden Sie die   Tasten.

Im manuellen Modus sehen Sie folgendes:

Halten -> Schließt

Wie voll / leer die Batterie ist.

Batterie: 100%

Der aktuelle Modus

1.Modus: Manuell

Hier können Sie das Steuerungselement auf Werkeinstellungen zurücksetzen

5. Werksreset



Die automatische Tür verwendet das 24-Stunden-Format, um Unklarheiten zu vermeiden. Die Uhrzeit wird zurückgesetzt, wenn die Batterien entfernt werden. Achten Sie darauf, die aktuelle Uhrzeit nach jedem Batteriewechsel zu aktualisieren.



Den Modus einstellen

1. Drücken Sie kurzzeitig , um die Modusanzeige im Menü zu finden

1.Modus: Manuell

2. Drücken und halten Sie  gedrückt, um den Modus zu ändern. Der aktuelle Modus wird aufblinken

1.Modus:  Manuell

3. Nutzen Sie  , um durch die Modi zu gehen

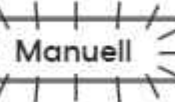
1.Modus:  Manuell

4. Drücken und halten Sie  gedrückt, um die Änderung zu bestätigen

1.Modus:  Zeit

--Gespeichert--



Einstellen der aktuellen Uhrzeit

1. Drücken Sie kurzzeitig , bis Sie Zeit erreicht haben

2. Zeit: 14:23

2. Drücken und halten Sie , bis die Minuten anfangen zu blinken



2. Zeit: 14:  23

3. Drücken Sie  oder , um die Minuten einzustellen

2. Zeit: 14:  05

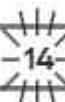
4. Drücken Sie , um zu den Stunden zu wechseln. Sie blinken, wenn sie ausgewählt sind

2. Zeit:  14 :05

5. Drücken Sie  oder , um die Stunden einzustellen

2. Zeit:  18 :05

6. Drücken und halten Sie  gedrückt, um zu bestätigen.

--Gespeichert--

Auf der Anzeige wird nun zu sehen sein: -Gespeichert-

Die Öffnungszeit einstellen

1. Drücken Sie kurzzeitig  , bis Sie die Anzeige rechts erreicht haben

3. Öffnen @ 01:00

2. Drücken und halten Sie  , bis die Minuten anfangen zu blinken

3. Öffnen @ 01:00

3. Drücken Sie  oder  , um die Minuten einzustellen

3. Öffnen @ 01:30

4. Drücken Sie  , um zu den Stunden zu wechseln. Sie blinken, wenn sie ausgewählt sind

3. Öffnen @ 01:30

5. Drücken Sie  oder  , um die Stunden einzustellen

3. Öffnen @ 08:30

6. Drücken und halten Sie  gedrückt, um zu bestätigen.

--Gespeichert--



Schließzeit einstellen

1. Drücken Sie kurzzeitig  bis Sie die Anzeige rechts erreicht haben

4. Schließen @ 01:00

2. Drücken und halten Sie  , bis die Minuten anfangen zu blinken



4. Schließen @ 01:00

3. Drücken Sie  oder  um die Minuten einzustellen

4. Schließen @ 01:15

4. Drücken Sie  , um zu den Stunden zu wechseln. Sie blinken, wenn sie ausgewählt sind

4. Schließen @ 01:15

5. Drücken Sie  oder  um die Stunden einzustellen

4. Schließen @ 19:15

6. Drücken und halten Sie  gedrückt, um zu bestätigen.

--Gespeichert--



Wenn sich das Lichtniveau an der Stelle, an der sich das Bedienfeld befindet, häufig ändert (z.B. in verkehrsreicher Umgebung), funktioniert der Lichtmodus möglicherweise nicht wie erwartet - schalten Sie in diesem Fall bitte auf den Zeitmodus um.

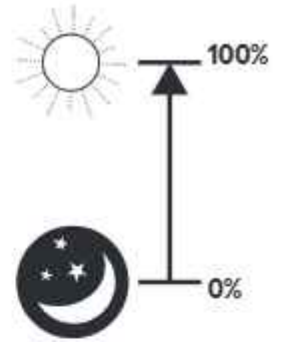



Den Modus einstellen

1. Drücken Sie kurzzeitig , um den richtigen Modus im Menü zu finden

1. Modus: Manuell

2. Drücken und halten Sie  gedrückt, um den Modus zu ändern. Der aktuelle Modus wird aufblinken

1. Modus: **Manuell**

3. Nutzen Sie  , um durch die Modi zu gehen

1. Modus: **Manuell**

4. Drücken und halten Sie  gedrückt, um die Änderung zu bestätigen

1. Modus: **Licht**

--Gespeichert--

Die Lichtempfindlichkeit für die Türöffnung einstellen



Der Wert der Lichtintensität für das Öffnen der Tür muss höher eingestellt sein als der Wert der Lichtintensität für das Schließen der Tür. Die beiden Werte sollten mindestens 10% auseinander liegen. Wir empfehlen, mit den Werten 13 und 3 zu beginnen und sie dann entsprechend anzupassen, da der Standort des Hühnerstalls die Lichtverhältnisse beeinflussen kann. Anpassungen können auch mit dem Wechsel der Jahreszeiten erforderlich werden

1. Drücken Sie kurzzeitig , bis Sie die Anzeige rechts erreicht haben

3. Öffnen @ 27

2. Drücken und halten Sie  , bis die Zahlen anfangen zu blinken

3. Öffnen @ **27**

3. Drücken Sie  oder , um das Lichtniveau einzustellen

3. Öffnen @ **13**

4. Drücken und halten Sie  gedrückt, um zu bestätigen.

--Gespeichert--

Die Lichtempfindlichkeit für die Türschließung einstellen

1. Drücken Sie kurzzeitig , bis Sie die Anzeige rechts erreicht haben

4. Schließen @ 6

2. Drücken und halten Sie , bis die Zahlen anfangen zu blinken

4. Schließen @ 6

3. Drücken Sie  oder , um das Lichtniveau einzustellen

4. Schließen @ 3

4. Drücken und halten Sie  gedrückt, um zu bestätigen.

--Gespeichert--

Öffnungsverzögerung einstellen



Die Werkseinstellung der Autodoor ist auf eine Verzögerung von 20 Minuten, nachdem das Lichtniveau den erforderlichen Wert erreicht hat, fixiert. Sie können diese 20 Minuten nicht unterschreiten und daher nur zusätzliche Minuten Verzögerung manuell einstellen. Dies ist erforderlich, um ein versehentliches Öffnen oder Schließen der Tür zu verhindern, sollte sich das Lichtniveau kurzzeitig ändern, z. B. falls ein Auto mit eingeschalteten Scheinwerfern vorbeifährt.

1. Drücken Sie kurzzeitig , bis Sie die Anzeige rechts erreicht haben

5. Öffnungsverzögerung 0m

2. Drücken und halten Sie , bis die Zahlen anfangen zu blinken

5. Öffnungsverzögerung 0m

3. Drücken Sie  oder , um die Minutenzahl einzustellen

5. Öffnungsverzögerung 7m

4. Drücken und halten Sie  gedrückt, um zu bestätigen.

--Gespeichert--

Schließverzögerung einstellen



Gleiches Prinzip wie bei einer Öffnungsverzögerung – siehe oben.

1. Drücken Sie kurzzeitig , bis Sie die Anzeige rechts erreicht haben

6. Schließverzögerung 0m

2. Drücken und halten Sie , bis die Zahlen anfangen zu blinken

6. Schließverzögerung 0m

3. Drücken Sie  oder , um die Minutenzahl einzustellen

6. Schließverzögerung 10m

4. Drücken und halten Sie  gedrückt, um zu bestätigen.

--Gespeichert--

56

Calibrage

Quand vous démarrez la Porte Automatique Omlet pour la première fois, elle devra détecter la position de la porte. Appuyez longuement sur **OK** le bouton .

La porte se calibrera ensuite d'elle-même en faisant un aller-retour sur le rail. Assurez-vous que rien ne vienne la bloquer pendant le calibrage.

Lors du processus de calibrage, le tableau de bord affichera le message suivants :

Calibrating...

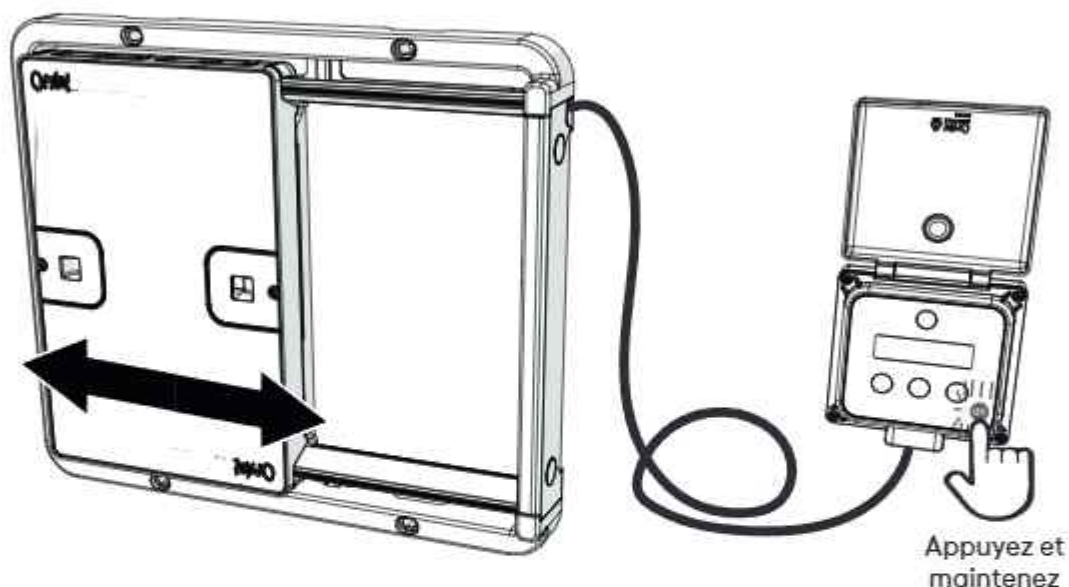

57

Changer la langue

1. Appuyez sur le bouton  pour défiler dans le menu jusqu'à cet écran :

Language: En

2. Gidez **OK** appuyé pour changer la langue. La langue actuelle clignotera

Language:  En

3. Utilisez  ou  pour choisir la langue

Language:  Fr

4. Gardez **OK** appuyé pour confirmer la langue

--Enregistré--

La Porte Automatique Omlet dispose de trois modes :

• **MANUEL** - la porte s'ouvre et se ferme en appuyant longuement sur le bouton .

→ 59

• **HORAIRE** - vous pouvez programmer les heures d'ouverture et de fermeture de la porte.

→ 60

• **LUMINOSITÉ** - il s'agit du mode par défaut : la porte s'ouvre et se ferme en fonction de la lumière ambiante.

→ 61



Appuyez sur l'un des trois boutons   .
L'écran affichera :

Tenir pr Ouvrir

ou

Tenir pr Fermer

Appuyez et maintenez la touche  pour ouvrir ou fermer la porte

Pour parcourir le menu, appuyez sur   pour faire défiler les rubriques

Dans le menu du mode MANUEL, vous verrez ceci :

Tenir pr Ouvrir

Ceci vous indique la charge de la batterie :

Batterie: 100%

Ceci vous montre le mode actuellement utilisé :

1. Mode: Manuel

Ceci vous permet de rétablir les réglages d'origine et annulera tout changement effectué :

5. Param. Usine



La porte automatique utilise le format de 24 heures afin d'éviter toute ambiguïté. L'heure se réinitialise lorsque les piles sont retirées. Assurez-vous de mettre à jour l'heure actuelle après chaque changement de pile.

Activer le mode

1. Appuyez sur  sans le maintenir enfoncé pour faire défiler le menu jusqu'au mode de votre choix

1. Mode: Manuel

2. Appuyez et maintenez  pour pouvoir changer de mode. Le mode actuellement utilisé s'affichera en clignotant

1. Mode: Manuel

3. Utilisez   pour naviguer dans le menu

1. Mode: Manuel

4. Appuyez et maintenez  pour valider votre modification

1. Mode: Heure

--Enregistré--

Paramétrer l'horaire

1. Appuyez sur  sans le maintenir enfoncé jusqu'à atteindre le menu

2. Heure: 14:23

2. Appuyez et maintenez  jusqu'à voir les minutes clignoter

2. Heure: 14:23

3. Utilisez  et  pour modifier les minutes

2. Heure: 14:05

4. Appuyez sur  pour passer au réglage des heures qui clignoteront lorsqu'elles seront sélectionnées

2. Heure: 14:05

5. Utilisez  et  pour modifier les heures

2. Heure: 18:05

6. Appuyez longuement sur  pour valider. L'écran affichera --Enregistré--

--Enregistré--

Réglage de l'heure d'ouverture de la

1. Appuyez sur  sans le maintenir enfoncé jusqu'à atteindre le menu affiché ci-contre :
2. Appuyez et maintenez  jusqu'à ce que les minutes clignotent
3. Appuyez sur  ou  pour régler les minutes
4. Appuyez sur  pour passer au réglage des heures qui clignoteront lorsqu'elles seront sélectionnées
5. Appuyez sur  ou  pour régler les heures
6. Appuyez longuement sur  pour valider

3. Ouvre @ 01:00

3. Ouvre @ 01:00

3. Ouvre @ 01:30

3. Ouvre @ 01:30

3. Ouvre @ 08:30

--Enregistré--

Réglage de l'heure de fermeture de la porte

1. Appuyez sur  sans le maintenir enfoncé jusqu'à atteindre le menu affiché ci-contre:
2. Appuyez et maintenez  jusqu'à voir les minutes clignoter
3. Appuyez sur  ou  pour régler les minutes
4. Appuyez sur  pour passer au réglage des heures qui clignoteront lorsqu'elles seront sélectionnées
5. Appuyez sur  ou  pour régler les heures
6. Appuyez longuement sur  pour valider.

4. Ferme @ 01:00

4. Ferme @ 01:00

4. Ferme @ 01:15

4. Ferme @ 01:15

4. Ferme @ 19:15

--Enregistré--



Si la luminosité vers le tableau de bord change fréquemment, le capteur de luminosité risque de ne pas fonctionner comme prévu. Veuillez alors utiliser le mode horaire

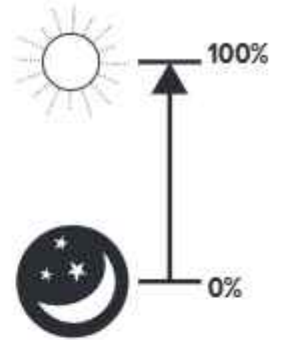

Activer le mode

1. Appuyez sur  sans le maintenir enfoncé jusqu'à atteindre le menu de sélection des modes

1. Mode: Manuel

2. Appuyez et maintenez  pour pouvoir changer de mode. Le mode actuellement utilisé s'affichera en clignotant

1. Mode: Manuel

3. Utilisez   pour naviguer dans le menu

1. Mode: Manuel

4. Appuyez et maintenez  pour valider votre modification

1. Mode: Luminosité

--Enregistré--

Choisir le niveau de luminosité pour l'ouverture de la porte



Le niveau de lumière lors de l'ouverture de la porte doit être réglé plus fort que le niveau de lumière lors de la fermeture de la porte. Ces deux valeurs doivent avoir une différence entre elles d'au moins 10 %. Nous vous recommandons au début de régler les niveaux de lumière sur 13 et 3, puis de les ajuster en fonction de l'emplacement du poulailler. Des ajustements peuvent être nécessaires avec les changements de saisons

1. Appuyez sur  sans le maintenir enfoncé jusqu'à atteindre le menu affiché ci-contre :

3. Ouvre @ 27

2. Appuyez et maintenez  jusqu'à ce que les chiffres clignotent

3. Ouvre @ 27



3. Appuyez sur  ou  pour régler le niveau

3. Ouvre @ 13

4. Appuyez longuement sur  pour valider

--Enregistré--

Choisir le niveau de luminosité pour la fermeture de la porte

1. Appuyez sur  sans le maintenir enfoncé jusqu'à atteindre le menu affiché ci-contre :
2. Appuyez et maintenez  jusqu'à ce que les chiffres clignotent
3. Appuyez sur  ou  pour régler le niveau
4. Appuyez longuement sur  pour valider

4. Ferme @ 6

4. Ferme @ 6

4. Ferme @ 3

--Enregistré--

Réglage du délai d'ouverture de la

 Par défaut, la Porte Automatique s'ouvre ou se ferme 20 minutes après que la luminosité requise soit atteinte. Vous pouvez augmenter ce délai mais vous ne pourrez pas aller en dessous de 20 minutes. Ceci est prévu pour éviter des ouvertures ou fermetures accidentelles si le capteur de lumière se trouve éclairé ou obstrué pendant une courte période, par exemple si une voiture passe avec ses phares allumés.

1. Appuyez sur  sans le maintenir enfoncé jusqu'à atteindre le menu affiché ci-contre:
2. Appuyez et maintenez  jusqu'à voir les chiffres clignoter
3. Appuyez sur  ou  pour modifier les minutes
4. Appuyez longuement sur  pour valider.

5. Délai Ouverture 0m



5. Délai Ouverture 0m

5. Délai Ouverture 7m

--Enregistré--

Réglage du délai de fermeture de la porte

Même principe que pour le délai d'ouverture – Voir ci-dessus.

1. Appuyez sur  sans le maintenir enfoncé jusqu'à atteindre le menu affiché ci-contre :
2. Appuyez et maintenez  jusqu'à ce que les chiffres clignotent
3. Appuyez sur  ou  pour modifier les minutes
4. Appuyez longuement sur  pour valider

6. Délai Fermeture 0m

6. Délai Fermeture 0m

6. Délai Fermeture 10m

--Enregistré--

56 Afstellen

Wanneer de automatische deur voor het eerst wordt geactiveerd, moet het de positie van de deur vaststellen. Houd de **OK** knop ingedrukt.

De automatische deur zal zichzelf afstellen door de deur eenmaal in beide richtingen te bewegen. Zorg ervoor dat de deur tijdens het afstellen niet wordt geblokkeerd.

Tijdens het kalibreren geeft het bedieningspaneel het volgende weer:

Calibrating...

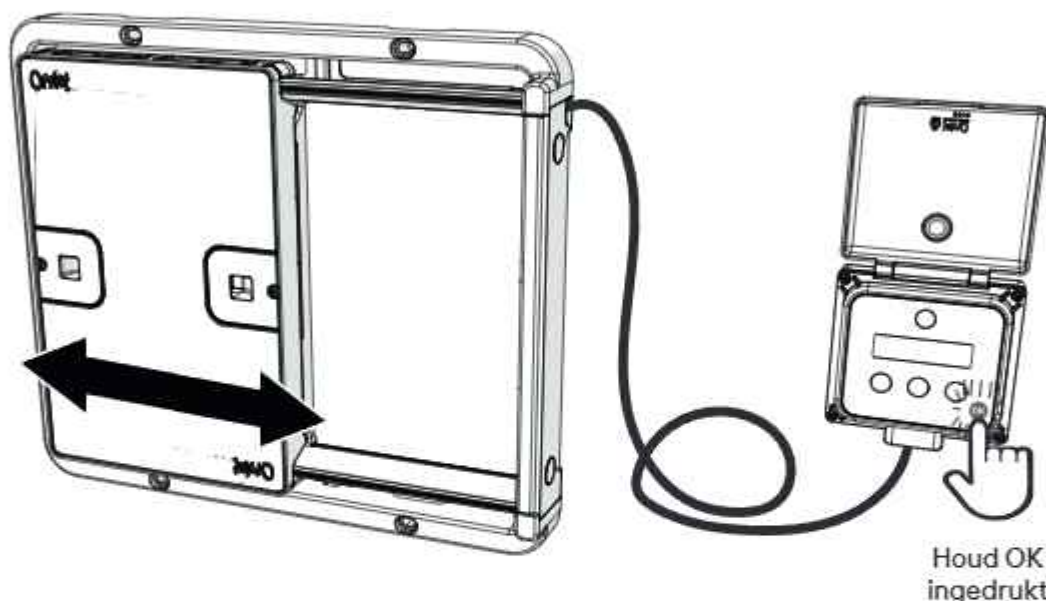

57 Taal wijzigen

1. Druk op de  knop om door het menu te scrollen totdat u dit scherm bereikt:

Language: En

2. Houd **OK** ingedrukt om de taal te wijzigen. De huidige taal zal knipperen

Language:  En

3. Gebruik  of  om door de talen te scrollen totdat u de gewenste taal bereikt

Taal:  NI

4. Houd **OK** ingedrukt om de geselecteerde taal te bevestigen

--Opgeslagen--

De automatische deur heeft 3 modes:

• **MANUAL** - De deur opent en sluit wanneer u de **OK** knop ingedrukt houdt.

→ 59

• **TIME** - De automatische deur opent en sluit op een door u ingesteld moment van de dag.

→ 60

• **LIGHT** - Dit is de standaardinstelling. De automatische deur opent door middel van de lichtsensor.

→ 61



Druk op de   **OK** knop en op het scherm verschijnt

Druk voor Open

of

Druk voor Sluit

Houd de **OK** knop ingedrukt om de deur te openen of sluiten.

Druk om het menu te doorlopen  

In het Manual-mode menu ziet u:

Druk voor Open

Dit geeft het batterijpercentage weer:

Batterij: 100%

Dit geeft de stand-instelling weer:

1. Modus: Manueel

Dit geeft u de mogelijkheid de bedieningsinstellingen terug te zetten naar de standaardinstellingen na elke wijziging die u heeft gemaakt.

5. Factory Reset



De automatische deur heeft een 24-uursnotatie om verwarring te voorkomen. De tijd wordt gereset wanneer de batterijen worden verwijderd. Zorg ervoor dat u de huidige tijd bijwerkt na elke batterijwissel.



De mode instellen

1. Houd  kort ingedrukt om de opties te doorlopen totdat u de mode heeft bereikt

1.Modus: Manueel

2. Houd  ingedrukt om de mode aan te passen. De huidige mode zal gaan knipperen

1.Modus: Manueel

3. Gebruik   om door de modes te scrollen

1.Modus: Manueel

4. Houd  ingedrukt om de aanpassing van de mode te bevestigen

1. Modus: Tijd

--Opgeslagen--



Tijd instellen

1. Houd  kort ingedrukt om naar het mode-menu te gaan

2. Tijd: 14:23

2. Houd  ingedrukt totdat de minuten gaan knipperen

2. Tijd: 14:-23-

3. Druk  of  om de minuten in te stellen

2. Tijd: 14:-05-

4. Druk  om de uren te selecteren. Deze gaan ter bevestiging knipperen.

2. Tijd: -14-:05

5. Druk  of  om de uren in te stellen

2. Tijd: -18-:05

6. Druk  om te bevestigen. Op het scherm verschijnt -Opgeslagen-

--Opgeslagen--

Instellen van de openingstijd

1. Houd  kort ingedrukt om het scherm rechts te bereiken

3. Open @ 01:00

2. Houd  ingedrukt totdat de minuten gaan knipperen

3. Open @ 01:-00-

3. Druk  of  om de minuten in te stellen

3. Open @ 01:-30-

4. Druk  om de uren te selecteren. Deze gaan ter bevestiging knipperen

3. Open @ -01:-30

5. Druk  of  om de uren in te stellen

3. Open @ -08:-30

6. Houd  ingedrukt om te bevestigen.

--Opgeslagen--

Instellen van de sluitingstijd

1. Houd  kort ingedrukt om het scherm rechts te bereiken

4. Sluit @ 01:00

2. Houd  ingedrukt totdat de minuten gaan knipperen

4. Sluit @ 01:-00-

3. Druk  of  om de minuten in te stellen

4. Sluit @ 01:-15-

4. Druk  om de uren te selecteren. Deze gaan ter bevestiging knipperen

4. Sluit @ -01:-15

5. Druk  of  om de uren in te stellen

4. Sluit @ -19:-15

6. Houd  ingedrukt om te bevestigen.

--Opgeslagen--



Wanneer het lichtniveau op de plek waar het bedieningspaneel zicht bevindt regelmatig wijzigt (bijvoorbeeld in een drukke omgeving), functioneert de Light modus mogelijk niet naar verwachting - schakel in dit geval over naar de Time modus.

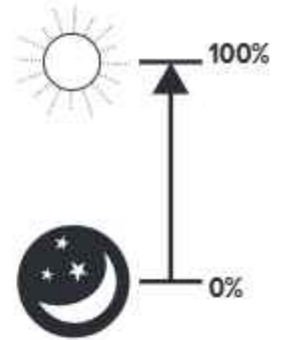

De mode instellen

1. Houd  kort ingedrukt om de opties te doorlopen totdat u de mode heeft bereikt
2. Houd  ingedrukt om de mode aan te passen. De huidige mode zal gaan knippen
3. Gebruik   om door de modes te scrollen
4. Houd  ingedrukt om de aanpassing van de mode te bevestigen

1.Modus: Manueel

1.Modus: Manueel

1.Modus: Manueel



1. Modus: Licht

--Opgeslagen--

Instellen van het lichtniveau voor openen



Het lichtniveau waarop de deur opent moet op een hoger percentage worden ingesteld dan het lichtniveau waarop de deur sluit. De twee waarden moeten minimaal 10% bij elkaar vandaan liggen. We raden aan om te beginnen met 13% en 3% en de waarden indien nodig aan te passen. Dit omdat de locatie van het kippenhok van invloed kan zijn op het lichtniveau. Het kan nodig zijn deze waarden aan te passen, afhankelijk van het seizoen

1. Houd  kort ingedrukt om het scherm rechts te bereiken
2. Houd  ingedrukt totdat de cijfers gaan knippen
3. Druk  of  om het lichtniveau in te stellen
4. Houd  ingedrukt om te bevestigen.





3. Open @ 27

3. Open @ 27

3. Open @ 13

--Opgeslagen--

Instellen van het lichtniveau voor sluiten

1. Houd  kort ingedrukt om het scherm rechts te bereiken
2. Houd  ingedrukt totdat de cijfers gaan knipperen
3. Druk  of  om het lichtniveau in te stellen
4. Houd  ingedrukt om te bevestigen.

4. Sluit @ 6





4. Sluit @ 6

4. Sluit @ 3

--Opgeslagen--

Instellen van de open-vertraging

 Als standaardinstelling sluit de Autodoor met een vertraging van 20 minuten nadat het ingestelde lichtniveau is bereikt. Het is niet mogelijk deze tijd te verkorten en er kunnen alleen manueel minuten aan worden toegevoegd. Dit is om te voorkomen dat de deur onbedoeld opent of sluit wanneer het lichtniveau tijdelijk wijzigt, bijvoorbeeld wanneer een auto met koplampen aan langsrijdt.

1. Houd  kort ingedrukt om het scherm rechts te bereiken
2. Houd  ingedrukt totdat de cijfers gaan knipperen
3. Druk  of  om de minuten in te stellen
4. Houd  ingedrukt om te bevestigen.

5. Open Vertraging 0m

5. Open Vertraging 0m

5. Open Vertraging 7m

--Opgeslagen--

Sluitingsvertraging instellen

 Dezelfde principes zijn van toepassing bij vertragingen in het openen - zie hierboven.

1. Houd  kort ingedrukt om het scherm rechts te bereiken
2. Houd  ingedrukt totdat de cijfers gaan knipperen
3. Druk  of  om de minuten in te stellen
4. Houd  ingedrukt om te bevestigen.

6. Sluit Vertraging 0m

6. Sluit Vertraging 0m

6. Sluit Vertraging 10m

--Opgeslagen--

56

Calibrazione

Quando usate per la prima volta l'Auto Porta dovete calibrarla. Tenete premuto il pulsante **OK**.

L'Auto Porta procederà automaticamente alla calibrazione facendo scorrere la porta in entrambe le direzioni. Controllate che la porta non sia bloccata da oggetti o materiali durante la fase di calibrazione.

Durante la calibrazione sul pannello di controllo si leggerà:

Calibrating...

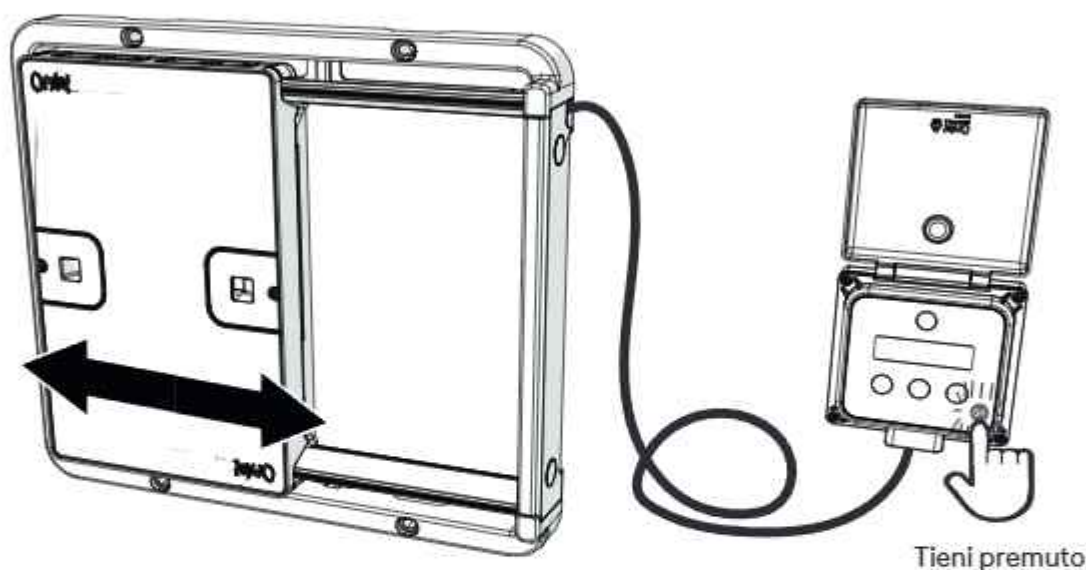

57

Cambio lingua

1. Premere **↓** per scorrere il menu fino a raggiungere questa schermata:

Language: En

2. Premere e tenere premuto **OK** per modificare la lingua. La lingua corrente lampeggerà

Language: **En**

3. Utilizzare **↑** o **↓** per scorrere le lingue finché non avrete trovato quella desiderata

Lingua: **It**

4. Premete e tenete premuto **OK** per confermare l'aggiornamento della lingua

--Salvato--

L'Auto Porta ha 3 modalità d'uso:

- MANUALE (Manual) - L'Auto Porta si apre e chiude premendo il pulsante

OK

→ 59

- TEMPO (Time) - Potete impostare un orario specifico nel quale l'Auto Porta si apre e chiude.

→ 60

- LUCE (Light) - Questa è la modalità pre-impostata. L'Auto Porta si apre e chiude grazie al sensore di luminosità.

→ 61

Premete uno qualsiasi dei pulsanti



e sullo schermo apparirà:

Premi -> Aprire

oppure

Premi -> Chiudere

Tenere premuto il pulsante **OK** per aprire/chiudere la porta.

Per scorrere le voci del menù premere i pulsanti



Sul menù in modalità manuale vedrete le seguenti voci:

Premi -> Aprire

Livello batteria

Batteria: 100%

Modalità (Mode) in uso

1. Mod: Manuale

Questa opzione vi permette di resettare le impostazioni e riportarle a quelle iniziali.

5. Ripr. Fabb.



La porta automatica utilizza un orologio di 24 ore per evitare ambiguità. Il tempo si azzererà quando le batterie vengono estratte. Assicurati di aggiornare l'ora corrente dopo ogni sostituzione della batteria.

Impostare la Modalità

1. Premere brevemente il pulsante  per scorrere le varie opzioni fino a raggiungere la modalità (Mode)

1. Mod: Manuale

2. Tenere premuto il pulsante , la modalità in uso inizierà a lampeggiare.

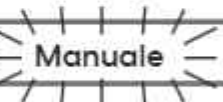
1. Mod:  Manuale

3. Usare i pulsanti   per scorrere le varie modalità

1. Mod:  Manuale

4. Tenere premuto  per selezionare e confermare la nuova modalità

1. Mod:  Tempo

--Salvato--

Regolare l'orario attuale

1. Premere brevemente il pulsante  per selezionare le impostazioni

2. Orario: 14:23

2. Tenere premuto  fino a quando il blocco dei minuti inizierà a lampeggiare

2. Orario: 14:  23

3. Premere  o  per impostare i minuti

2. Orario: 14:  05

4. Premere  per confermare e spostarsi al blocco delle ore che inizieranno a lampeggiare

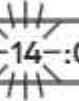
2. Orario:  14 :05

5. Premere  o  per impostare l'ora

2. Orario:  18 :05

6. Tenere premuto  per confermare. Sullo schermo apparirà la conferma: --Salvato--

--Salvato--

Impostare l'orario di apertura

1. Premere brevemente il pulsante  per raggiungere il display a destra

3. Aperto @ 01:00

2. Tenere premuto  fino a quando il blocco dei minuti inizierà a lampeggiare

3. Aperto @ 01:-00-

3. Premere  o  per impostare i minuti

3. Aperto @ 01:-30-

4. Premere  per confermare e spostarsi al blocco delle ore che inizieranno a lampeggiare

3. Aperto @ -01:-30

5. Premere  o  per impostare l'ora

3. Aperto @ -08:-30

6. Tenere premuto  per confermare.

--Salvato--

Impostare l'orario di chiusura

1. Premere brevemente il pulsante  per raggiungere il display a destra

4. Chiuso @ 01:00

2. Tenere premuto  fino a quando il blocco dei minuti inizierà a lampeggiare

4. Chiuso @ 01:-00-

3. Premere  o  per impostare i minuti

4. Chiuso @ 01:-15-

4. Premere  per confermare e spostarsi al blocco delle ore che inizieranno a lampeggiare

4. Chiuso @ -01:-15

5. Premere  o  per impostare l'ora

4. Chiuso @ -19:-15

6. Tenere premuto  per confermare.

--Salvato--



Se il livello di luminosità dove si trova il pannello di controllo cambia frequentemente (ad esempio molti vicini) la funzione luminosità rischia di non funzionare come ci si aspetterebbe - passate alla modalità oraria

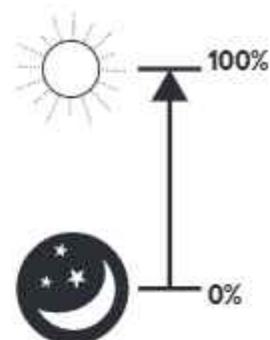

Impostare la Modalità

1. Premere brevemente il pulsante  per scorrere le varie opzioni fino a raggiungere la modalità (Mode)

1. Mod: Manuale



2. Tenere premuto il pulsante , la modalità in uso inizierà a lampeggiare.

1. Mod:  Manuale 

3. Usare i pulsanti   per scorrere le varie modalità

1. Mod:  Manuale 

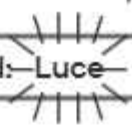
4. Tenere premuto  per selezionare e confermare la nuova modalità

1. Mod:  Luce 

--Salvato--

Impostare il livello di luce per l'apertura



I livelli di luce dell'apertura della porta dovrebbero essere impostati con una percentuale più alta rispetto ai livelli di luce della chiusura porta. I due valori dovrebbero essere almeno del 10% distanziati l'uno dall'altro. Raccomandiamo di iniziare da 13 e 3 e poi aggiustare perché a seconda del posizionamento del pollaio, i livelli di luce possono risentirne. Potrebbero essere necessari degli aggiustamenti con i cambi di stagione.

1. Premere brevemente il pulsante  per raggiungere il display a destra

3. Aperto @ 27

2. Tenere premuto  fino a quando i numeri non inizieranno a lampeggiare

3. Aperto @  27 

3. Premere  o  per impostare il livello

3. Aperto @  13 

4. Premere  per confermare.

--Salvato--

Impostare il livello di luce per la

1. Premere brevemente il pulsante  per raggiungere il display a destra

2. Tenere premuto  fino a quando i numeri non inizieranno a lampeggiare

3. Premere  o  per impostare il livello

4. Premere  per confermare.

4. Chiuso @ 6

4. Chiuso @ 

4. Chiuso @ 

--Salvato--

Impostare il ritardo di apertura

 Automaticamente la porta automatica si apre o si chiude 20 minuti dopo che la luminosità selezionata è stata raggiunta. Potete aumentare lo scarto ma non potete scendere sotto i 20 minuti. E' stato pensato per evitare aperture o chiusure accidentali in caso il livello di luminosità cambiasse per poco tempo come ad esempio una macchina che passa con i fari accesi

1. Premere brevemente il pulsante  per raggiungere il display a destra

2. Tenere premuto  fino a quando i numeri non inizieranno a lampeggiare

3. Premere  o  per impostare i minuti

4. Premere  per confermare.

5. Apert. Rit. 0m

5. Apert. Rit. 

5. Apert. Rit. 

--Salvato--

Impostare il ritardo di chiusura

 Stesso principio per ritardo di apertura - Vedi sopra.

1. Premere brevemente il pulsante  per raggiungere il display a destra

2. Tenere premuto  fino a quando i numeri non inizieranno a lampeggiare

3. Premere  o  per impostare i minuti

4. Premere  per confermare.

6. Chius. Rit. 0m

6. Chius. Rit. 

6. Chius. Rit. 

--Salvato--

56

Kalibrering

När du kopplar in din autodörr för första gången måste den känna av dörrrens position. Tryck och håll ner **OK** -knappen.

Autodörren kommer automatiskt kalibrera sig själv genom att skjuta dörren åt varje håll en gång. Se till att dörren inte är blockerad under kalibreringen.

Under kalibreringen kommer kontrollpanelen att visa:

Calibrating...

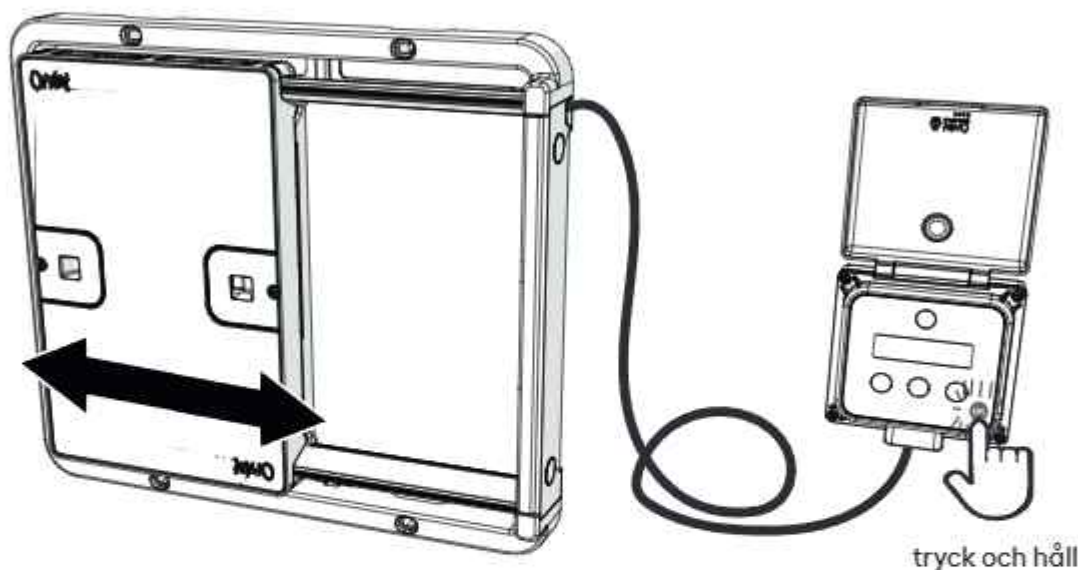

57

Ändra språk

1. Tryck på **↓** för att gå igenom menyn tills du kommer till den här skärmen:

Language: En

2. Tryck på och håll in **OK** för att ändra språket. Det nuvarande språkvalet kommer att blinka

Language: **En**

3. Använd **↑** eller **↓** för att bläddra bland språken tills du hittar det språk du vill använda

Språk: **SE**

4. Tryck på och håll in **OK** för att bekräfta ditt språkval

--Sparat--

Autodörren har 3 inställningar:

- **MANUAL** - Dörren kommer öppna och stängas om du håller inne **OK**-knappen.
- **TIME** - Du kan ställa in autodörren att öppnas och stängas vid speciella tidpunkter på dagen.
- **LIGHT** - Detta är standardinställningen. Autodörren kommer öppna med hjälp av ljussensorn.

→ 59

→ 60

→ 61



Tryck på någon av knapparna    så kommer skärmen visa:

Håll in -> Öppna

eller

Håll in -> Stänga

Håll ner  för att antingen öppna eller stänga dörren.

För att gå igenom menyn, tryck   för att gå igenom de olika menyvalen.

I den manuella inställningen kommer du se följande:

Håll in -> Öppna

Här visas batterinivån

Batteri: 100%

Här visas den nuvarande inställningen.

1. Läge: Manuell

Ger dig möjlighet att återställa till fabriksinställningarna efter att du har gjort ändringar

5. Factory Reset



Autodörren använder 24-timmarsklockan. Tiden återställs när batterierna tas ur. Se till att uppdatera den aktuella tiden efter varje batteribyte.

Ställa in

1. Tryck och håll ner  en kort stund och skrolla tills du kommer till rätt inställning

1. Läge: Manuell

2. Håll ner  för att kunna ändra inställningarna. Det nuvarande värdet kommer blinka

1. Läge: **Manuell**

3. Använd   för att välja

1. Läge: **Manuell**

4. Håll ner  för att bekräfta ändringar

1. Läge: **Tid**

--Sparat--

Att ställa in klockan

1. Tryck på  för att komma åt menyn

2. Tid: 14:23

2. Håll ner  tills minuterna börjar blinka

2. Tid: 14:**23**

3. Tryck på  eller  för att ställa in rätt minut

2. Tid: 14:**05**

4. Tryck på  för att ändra till timmar, de kommer blinka för att bekräfta ändringen

2. Tid:**14**:05

5. Tryck på  eller  för att ställa in rätt timme

2. Tid:**18**:05

6. Håll ner  för att bekräfta. Skärmen kommer visa -Sparat-

--Sparat--

Ställ in öppningstidpunkt

1. Tryck på  för att komma åt menyn till höger
2. Håll ner  tills minuterna börjar blinka
3. Tryck på  eller  för att ställa in rätt minut
4. Tryck på  för att ändra till timmar, de kommer blinka för att bekräfta ändringen
5. Tryck på  eller  för att ställa in rätt timme
6. Håll ner  för att bekräfta.

3. Öppna @ 01:00

3. Öppna @ 01:00







3. Öppna @ 01:30

3. Öppna @ 01:30

3. Öppna @ 08:30

--Sparat--

Ställ in stängningstidpunkt

1. Tryck på  för att komma åt menyn till höger
2. Håll ner  tills minuterna börjar blinka
3. Tryck på  eller  för att ställa in rätt minut
4. Tryck på  för att ändra till timmar, de kommer blinka för att bekräfta ändringen
5. Tryck på  eller  för att ställa in rätt timme
6. Håll ner  för att bekräfta.

4. Stäng @ 01:00

4. Stäng @ 01:00

4. Stäng @ 01:15

4. Stäng @ 01:15

4. Stäng @ 19:15

--Sparat--



Om ljusnivån där kontrollpanelen sitter ofta ändras (om du till exempel bor någonstans där många bilar kör förbi) kan ljusinställningen ibland inte fungera och du måste istället använda tidsinställningen

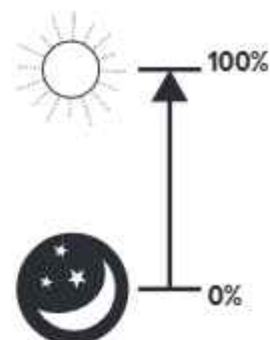

Ställa in

1. Tryck  på och skrolla tills du kommer till rätt inställning

1. Läge: Manuell

2. Håll ner  för att kunna ändra inställningarna. Det nuvarande värdet kommer blinka

1. Läge:  Manuell

3. Använd   för att välja

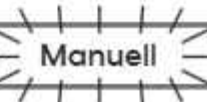
1. Läge:  Manuell

4. Håll ner  för att bekräfta ändringar

1. Läge:  Ljus

--Sparat--

Ställ in ljusnivå för öppning



Ljusnivån för öppning ska vara inställd på ett högre procenttal än den för stängning. De två värdena bör skilja åtminstone 10%. Vi rekommenderar att börja på 13 och 3, och sedan anpassa, eftersom hönshusets placering på kan påverka ljusnivåer. Du kan också behöva anpassa nivåerna efter årstiderna

1. Tryck på  för att komma åt meny till höger

3. Öppna @ 27

2. Håll ner  till siffrorna börjar blinka

3. Öppna @  27

3. Använd  och  för att välja rätt nivå

3. Öppna @  13

4. Håll ner  för att bekräfta.

--Sparat--

Ställ in ljusnivå för stängning

1. Tryck kort på  för att komma åt menyn till höger
2. Håll ner  till siffrorna börjar blinka
3. Använd  och  för att välja rätt nivå
4. Håll ner  för att bekräfta.

4. Stäng @ 6

4. Stäng @ 6

4. Stäng @ 3

--Sparat--

Ställ in öppningsfördröjning



Som standard har autodörren en fördröjning på 20 minuter efter att ljuset nått den valda nivån. Du kan inte gå under 20 minuter men kan manuellt lägga till ytterligare minuter. Detta är för att motverka att dörren öppnas eller stängs av misstag när ljussensorn antingen är blockerad eller något lyser på den under kortare perioder, som när en bil kör förbi med helljuset på.

1. Tryck på  för att komma åt menyn till höger
2. Håll ner  till siffrorna börjar blinka
3. Tryck på  eller  för att ställa in rätt minut
4. Håll ner  för att bekräfta ändringar.

5. Öppnings-Fördröjning 0m

5. Öppnings-Fördröjning 0m

5. Öppnings-Fördröjning 7m

--Sparat--

Ställ in stängningsfördröjning



Samme princip som ved åbningsforsinkelse - Se ovenfor.

1. Tryck på  för att komma åt menyn till höger
2. Håll ner  till siffrorna börjar blinka
3. Tryck på  eller  för att ställa in rätt minut
4. Håll ner  för att bekräfta ändringar.

6. Stängnings-Fördröjning 0m

6. Stängnings-Fördröjning 0m

6. Stängnings-Fördröjning 10m

--Sparat--

56

Kalibrering

Når du tilslutter din automatiske dør for første gang, skal den registrere dørpositionen. Tryk **OK** og hold knappen nede.

Den automatiske dør kalibrerer automatisk sig selv ved at køre døren en gang i hver retning. Sørg for, at den automatiske dør ikke er blokeret under kalibrering.

Under kalibrering vil kontrolpanelet vise:

Calibrating...

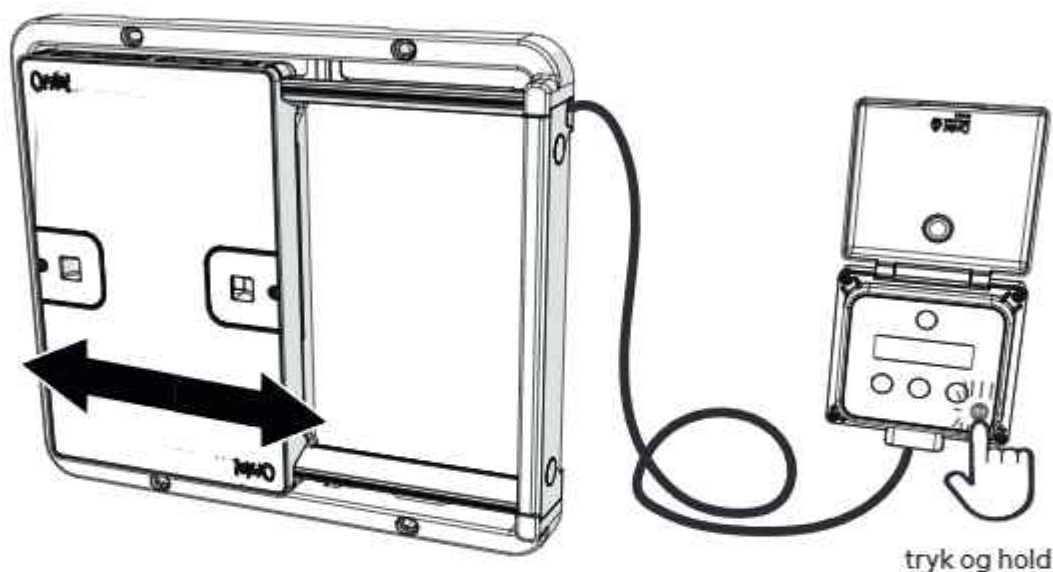

57

Skift sprog

1. Tryk på **↓** knappen for at bevæge dig igennem menuen indtil du når denne skærm:

Language: En

2. Tryk på **OK** og hold nede for at ændre sprog. Det nuværende sprogvvalg vil blinke

Language: **En**

3. Brug **↑** eller **↓** til at bevæge dig igennem sprogene indtil du kommer til dit ønskede sprog

Sprog: **Dk**

4. Tryk på **OK** og hold nede for at bekræfte dit sprogvvalg

--Gemt--

Den automatiske dør har 3 funktioner:

• **MANUAL** - Døren åbner og lukker, når du trykker  og holder knappen nede.

→ 59

• **TIME** - Du kan indstille den automatiske dør til at åbne og lukke på bestemte tidspunkter af dagen.

→ 60

• **LIGHT** - Dette er standardfunktionen. Den automatiske dør åbnes ved hjælp af lyssensoren.

→ 61

Tryk på en af de tre knapper   , og displayet vil vise:



Hold nede -> Åbn

eller

Hold nede -> Luk

Hold  knappen nede for at åbne eller lukke døren.

Du kan gennemgå hele menuen ved at trykke

  for at gå op og ned gennem menupunkterne.

I menuen for manuel funktion ser du følgende:

Hold nede -> Åbn

Her vises batteriernes opladningsniveau.

Batteri: 100%

Her vises den aktuelle funktionsindstilling.

1. Funktion: Manuel

Her har du mulighed for at gendanne kontrolpanelets fabriksindstillinger efter eventuelle ændringer.

5. Gendan fabriksindstilling



Den automatiske dør bruger 24-timers uret for at forhindre enhver tvetydighed. Tiden nulstilles, når batterierne tages ud. Sørg for at opdatere den aktuelle tid efter hvert batteriskift.



Valg af funktion

1. Tryk og slip  for at navigere igennem mulighederne indtil du når til funktionen

1. Funktion: Manuel

2. Tryk  og hold knappen nede for at skifte funktion. Den aktuelle funktion blinker

1. Funktion: Manuel

3. Brug   for at gå igennem de forskellige funktioner

1. Funktion: Manuel

4. Tryk  og hold nede for at bekræfte dit valg

1. Funktion: Tid

--Gemt--

Indstilling af klokkeslæt

1. Tryk og slip  for at nå punktet i funktionsmenuen

2. Tid Nu: 14:23

2. Tryk  og hold nede indtil minutterne begynder at blinke

2. Tid Nu: 14:23

3. Tryk  eller  for at indstille minutterne

2. Tid Nu: 14:05

4. Tryk  for at skifte til timer, timerne blinker når de er valgt

2. Tid Nu: 14:05









5. Tryk  eller  for at indstille timerne

2. Tid Nu: 18:05

6. Tryk  og hold nede for at bekræfte. Displayet viser -Gemt-

--Gemt--

Indstilling af åbningstidspunkt

1. Tryk og slip  for at finde displayet til højre
2. Tryk  og hold nede indtil minutterne begynder at blinke
3. Tryk  eller  for at indstille minutterne
4. Tryk  for at skifte til timer, timerne blinker når de er valgt
5. Tryk  eller  for at indstille timerne
6. Tryk  og hold nede for at bekræfte.

3. Åbn @ 01:00

3. Åbn @ 01:00

3. Åbn @ 01:30

3. Åbn @ 01:30

3. Åbn @ 08:30

--Gemt--

Indstilling af lukketidspunkt

1. Tryk og slip  for at finde displayet til højre
2. Tryk  og hold nede indtil minutterne begynder at blinke
3. Tryk  eller  for at indstille minutterne
4. Tryk  for at skifte til timer, timerne blinker når de er valgt
5. Tryk  eller  for at indstille timerne
6. Tryk  og hold nede for at bekræfte.

4. Luk @ 01:00

4. Luk @ 01:00

4. Luk @ 01:15

4. Luk @ 01:15

4. Luk @ 19:15

--Gemt--

61

Lyssensor funktion



Hvis lysniveauet ændrer sig ofte, der hvor kontrolpanelet er placeret (f.eks. i et travlt nabolag), vil lysfunktionen muligvis ikke fungere efter hensigten - anvend i så fald tidsfunktionen i stedet

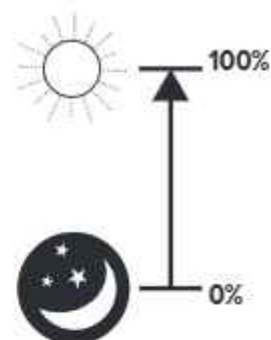



Valg af funktion

1. Tryk og slip  for at navigere igennem mulighederne indtil du når til funktionen

1. Funktion: Manuel

2. Tryk  og hold knappen nede for at skifte funktion. Den aktuelle funktion blinker

1. Funktion:  Manuel

3. Brug   for at gå igennem de forskellige funktioner

1. Funktion:  Manuel

1. Funktion:  Lys

4. Tryk  og hold nede for at bekræfte dit valg.

--Gemt--

Indstilling af lysniveau ved åbning



Lysniveauet for åbning af døren skal sættes til en højere procentdel end lysniveau ved lukning. Der skal være mindst 10% forskel mellem de to værdier. Vi anbefaler, at du starter med værdierne 13 og 3, og justerer derudfra efter behov, da hønsehusets placering kan påvirke mængden af lys. Justeringer kan også være nødvendige når årstiderne skifter

1. Tryk og slip  for at finde displayet til højre

3. Åbn @ 27

2. Tryk  og hold nede indtil tallene begynder at blinke

3. Åbn @  27

3. Tryk  eller  for at indstille niveauet

3. Åbn @  13

4. Tryk  og hold nede for at bekræfte.

--Gemt--

Indstilling af lysniveau ved lukning

1. Tryk og slip  for at finde displayet til højre

4. Luk @ 6

2. Tryk  og hold nede indtil tallene begynder at blinke

4. Luk @ 6

3. Tryk  eller  for at indstille niveauet

4. Luk @ 3

4. Tryk  og hold nede for at bekræfte.

--Gemt--

Indstilling af forsinkelse af åbningstidspunktet



I fabriksindstillingerne er den automatiske dør indstillet med 20 minutters forsinkelse, eller delay, efter at lyset rammer det valgte niveau. Delay kan ikke være under 20 minutter og kan kun manuelt indstilles ved at lægge yderligere tid til. Dette er for at forhindre utilsigtet åbning eller lukning af døren, når lyset ændrer sig i kortere perioder, f.eks. hvis en bil kører forbi og lyset fra forlygterne rammer sensoren.

1. Tryk og slip  for at finde displayet til højre

5. Åbn-Delay 0m

2. Tryk  og hold nede indtil tallene begynder at blinke

5. Åbn-Delay 0m

3. Tryk  eller  for at indstille minutterne

5. Åbn-Delay 7m

4. Tryk  og hold nede for at bekræfte.

--Gemt--

Indstilling af forsinkelse af lukketidspunktet



Samme princip som ved åbningsforsinkelse - Se ovenfor.

1. Tryk og slip  for at finde displayet til højre

6. Luk-Delay 0m

2. Tryk  og hold inde indtil tallene begynder at blinke

6. Luk-Delay 0m

3. Tryk  eller  for at indstille minutterne

6. Luk-Delay 10m

4. Tryk  og hold inde for at bekræfte.

--Gemt--

DE Öffnung bei Fehlfunktion · FR En cas de dysfonctionnement · NL Noodmodus bij falen · IT Sistema di apertura di emergenza · SE Öppna dörren i nödläge · DK Åbning af døren i nødstilfælde

In the event that

- 1) the motor fails,
- 2) the batteries go flat,
- 3) or there is any other blockage

you can move the door freely by releasing the rack.

- DE Für den Fall dass: 1) der Motor versagt, 2) die Batterien leer sind, 3) die Tür in anderer Weise blockiert ist, können Sie die Tür öffnen, indem Sie das Gestell lockern.

- FR Si l'un des problèmes suivants se présente : 1) le moteur tombe en panne, 2) les piles sont déchargées, 3) la porte est bloquée pour une raison quelconque, il est possible de manipuler la porte manuellement en la désolidarisant du rail.

- NL In het geval dat: 1) de motor faalt, 2) de batterijen leeg zijn, 3) er sprake is van een andere stagnatie, kunt u de deur vrij bewegen door het rek te verwijderen.

- IT In caso di emergenza quale: 1. rottura del motore, 2. batteria scarica, 3. ostruzione della porta, è possibile muovere la porta sbloccando il retro come illustrato di seguito.

- SE Ifall: 1) Motorn går sönder, 2) Batteriet dör, eller 3) Något annat blockerar dörren, kan du flytta dörren fritt genom att lossa på kuggstången.

- DK I tilfælde af: 1) motorfejl, 2) flade batterier eller 3) en anden form for blokering, kan du frit åbne og lukke døren ved at løsne tandstangen.

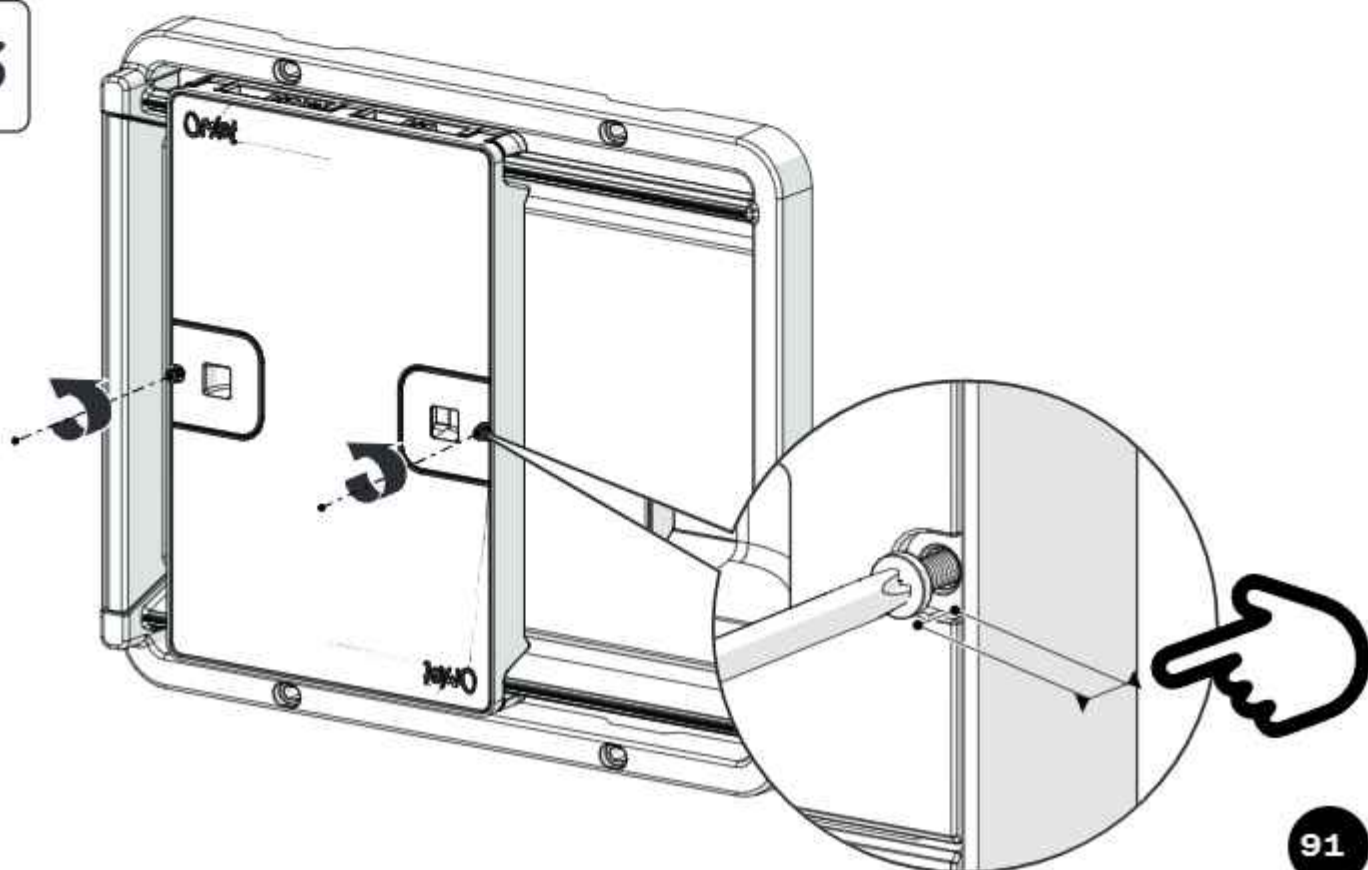
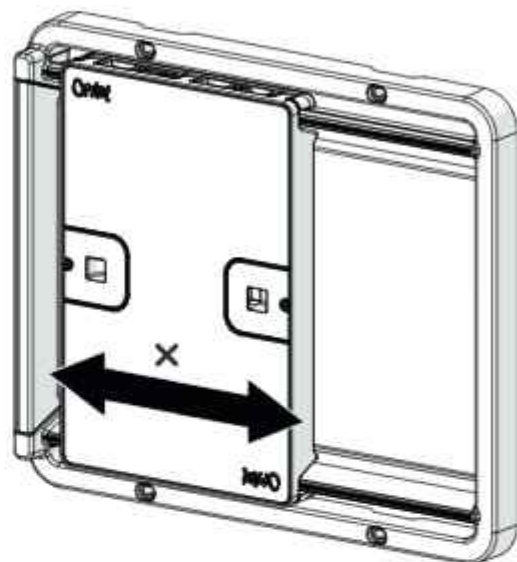

64

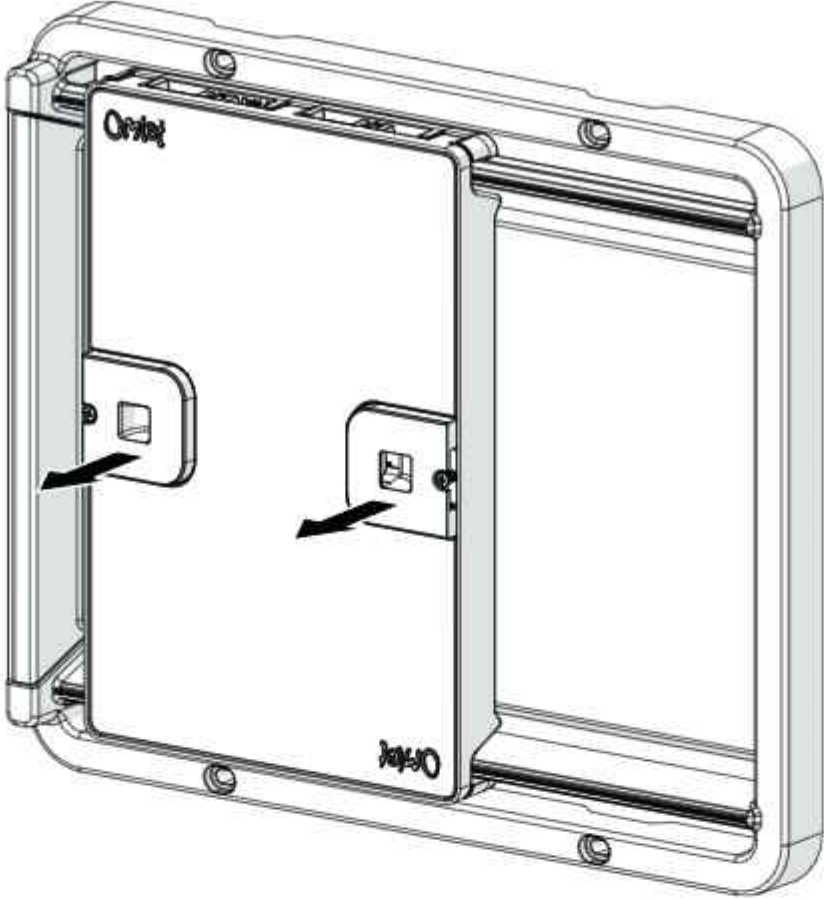

65

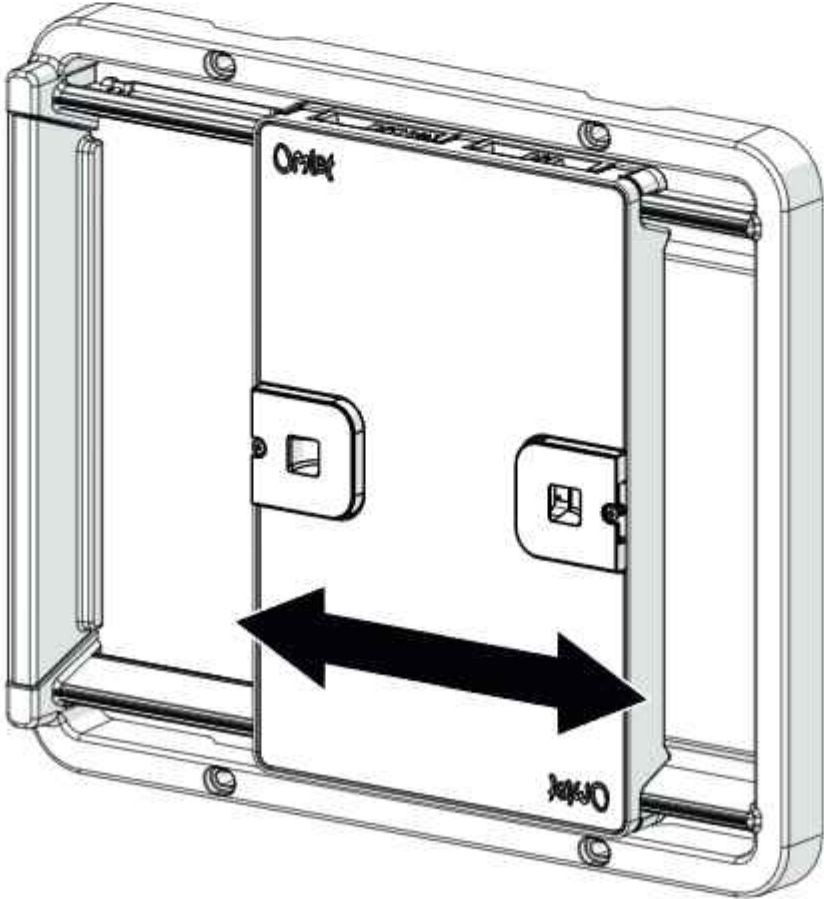

66

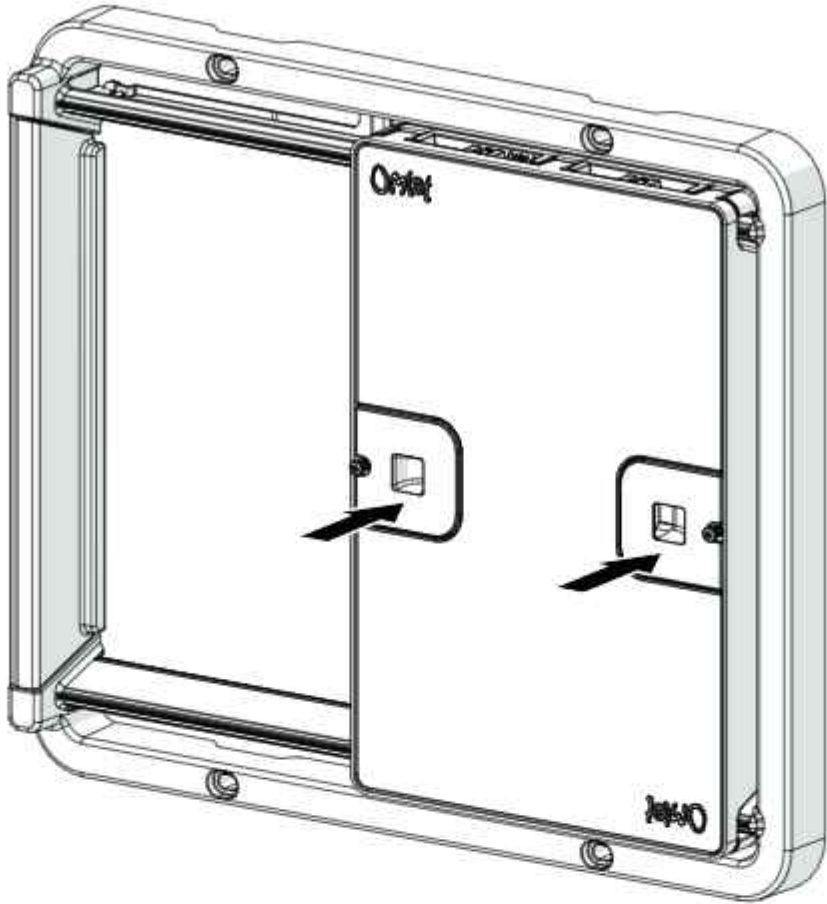

67

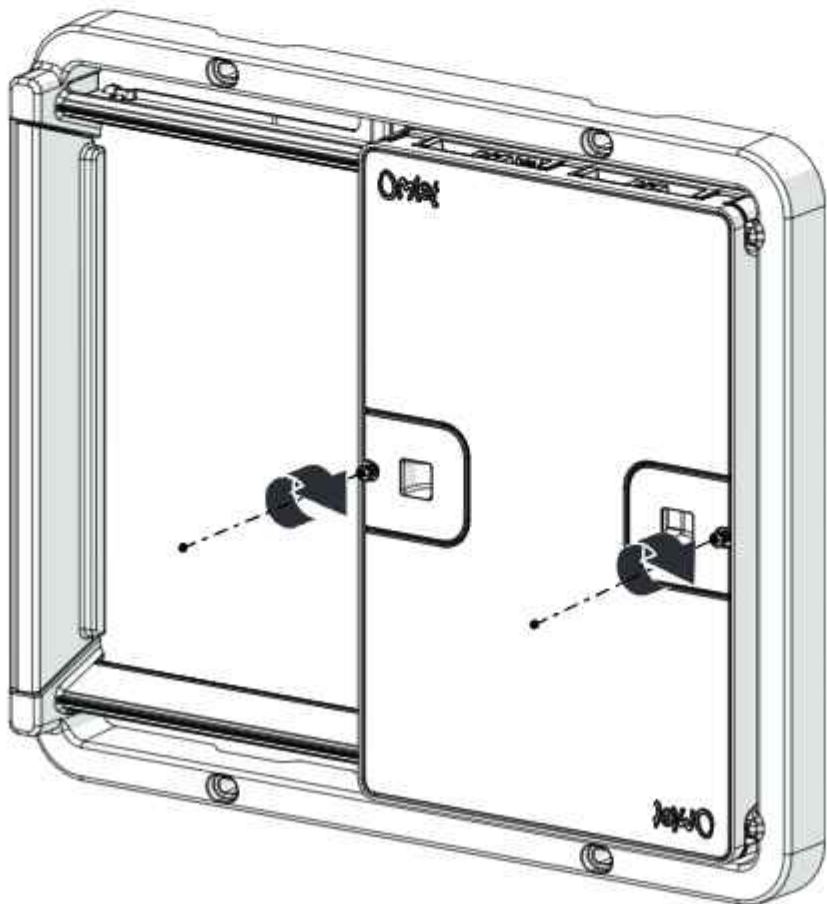

DE Die Automatische Tür reinigen · FR Nettoyage de la Porte Automatique Omlet · NL Het reinigen van de Autodoor · IT Pulizia · SE Rengöra autodörren · DK Rengøring af den automatiske dør

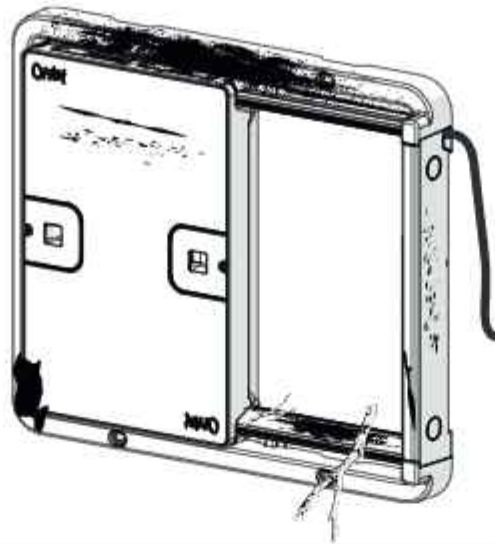

Please avoid cleaning your Autodoor with industrial chemicals or a jet wash. We recommend cleaning only with soap and water or a pet safe disinfectant and treating red mite with powder only.



DE Bitte reinigen Sie Ihr Autodoor nicht mit industriellen Chemikalien oder einer Jet-Wäsche. Wir empfehlen, sie nur mit Seife und Wasser oder mit einem haustiersicheren Desinfektionsmittel zu reinigen und Rote Vogelmilbe nur mit Pulver zu behandeln. · FR Veuillez ne pas nettoyer la Porte Automatique avec des produits de nettoyage chimiques ou un lavage au jet. Nous recommandons l'utilisation de savon et d'eau uniquement, ou d'un produit non toxique et de traiter les poux et les mites avec de la poudre uniquement. · NL Reinig uw Autodoor niet met industriële chemicaliën of een jet wash. Wij raden aan de Autodoor uitsluitend te reinigen met zeep en water of met een diervriendelijk reinigingsmiddel. Behandel bloedluis uitsluitend met een poeder tegen bloedluis. · IT Evitate di pulire Autodoor con detergenti chimici industriali o un lavaggio a getto. Raccomandiamo di pulire solo con acqua e sapone o un disinfettante sicuro per gli animali e trattare con polvere per gli acari rossi solamente. · SE Rengör inte din dörr med industrianpassade rengöringsmedel och kemikalier eller med en högtryckstvätt. Vi rekommenderar att du använder tvål och vatten eller ett husdjursäkert rengöringsmedel. · DK Undgå venligt at rengøre din automatiske dør til hønsehuset med industrielle kemikalier eller en jetwash. Vi anbefaler kun rengøring med vand og sæbe eller et dyrevenligt desinfektionsmiddel og behandling af blodmider kun med pulver.

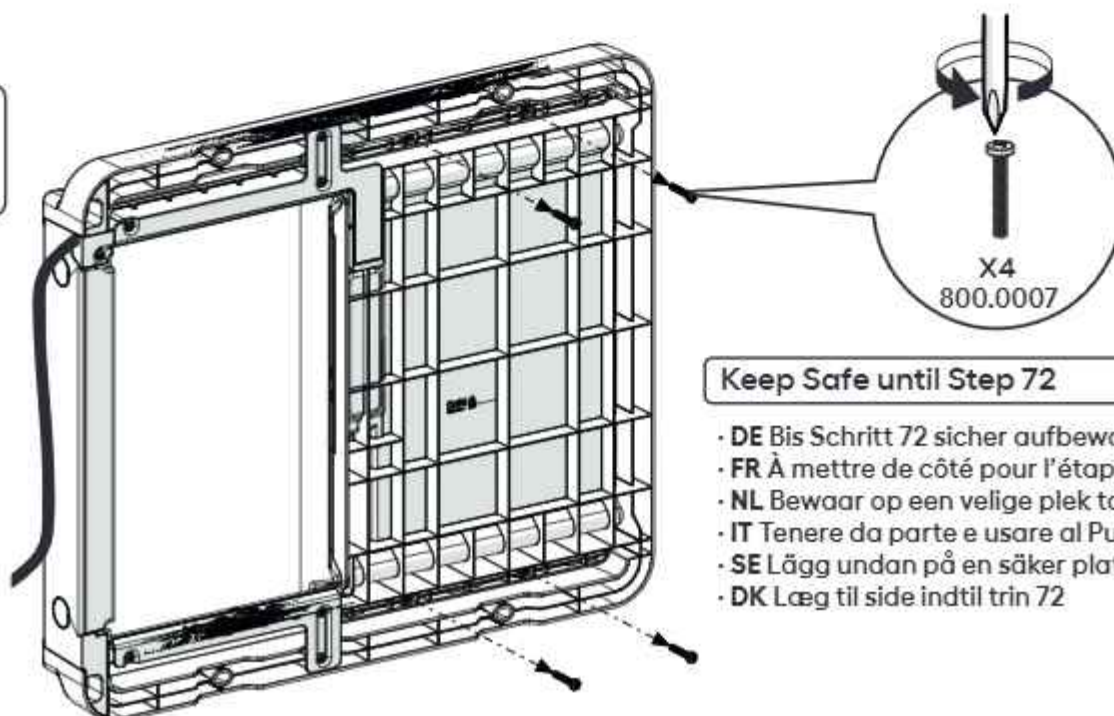

Keep Safe until Step 72



- DE Bis Schritt 72 sicher aufbewahren
- FR À mettre de côté pour l'étape 72
- NL Bewaar op een veilige plek tot stap 72
- IT Tenere da parte e usare al Punto 72
- SE Lägg undan på en säker plats till steg 72
- DK Læg til side indtil trin 72

70

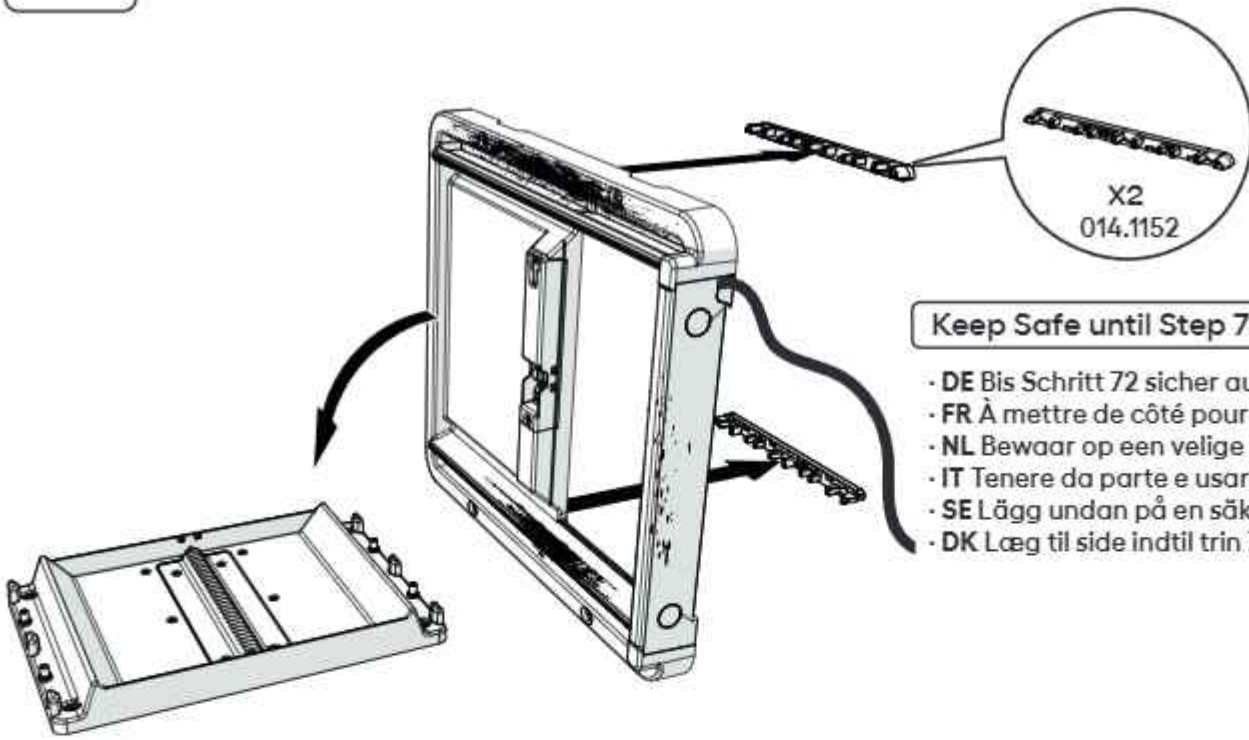

Keep Safe until Step 72

- DE Bis Schritt 72 sicher aufbewahren
- FR À mettre de côté pour l'étape 72
- NL Bewaar op een veilige plek tot stap 72
- IT Tenere da parte e usare al Punto 72
- SE Lågg undan på en säker plats till steg 72
- DK Læg til side indtil trin 72

71

Avoid getting water into the Gear Module

- DE Verhindern Sie, dass Wasser in das Getriebe kommt
- FR Évitez tout contact avec de l'eau au niveau de l'engrennage
- NL Voorkom dat er water in het tandwiel komt
- IT Evitate di bagnare l'ingranaggio
- SE Undvik att få in vatten i kugghjulsmodulen
- DK Undgå at få vand ind i tandhjulet

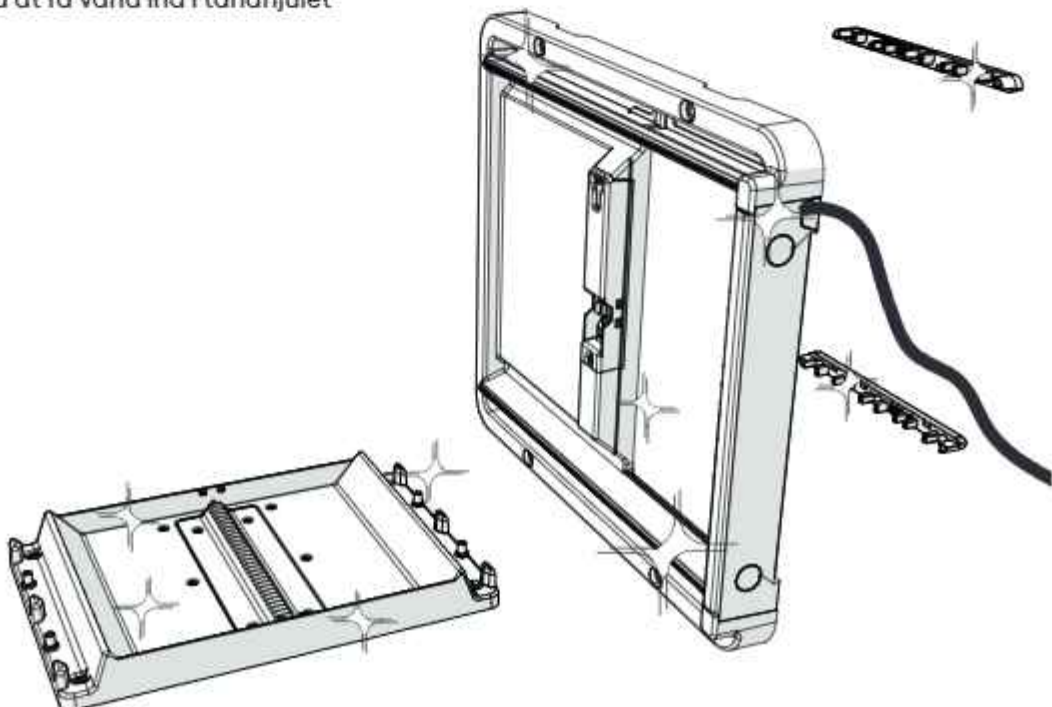

72

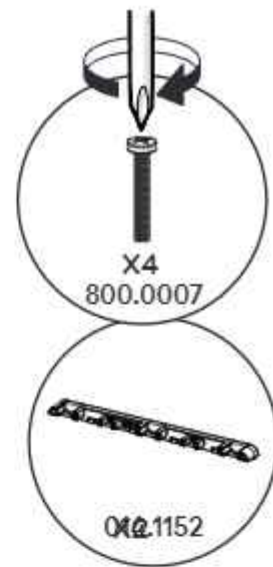
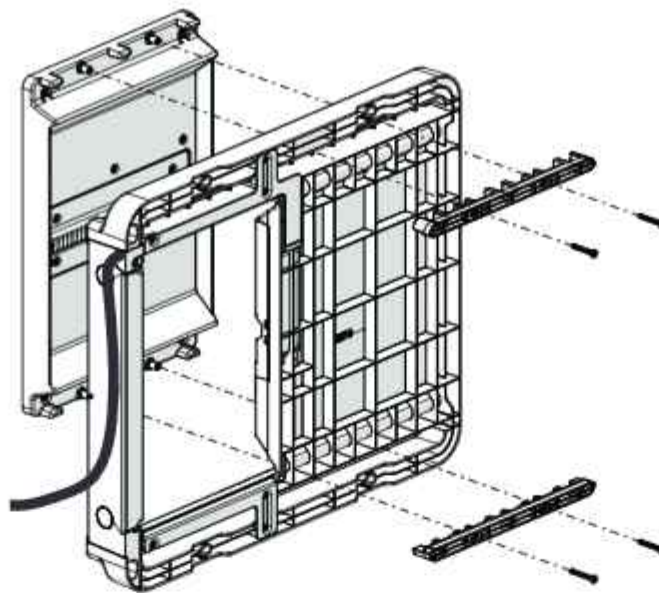

73

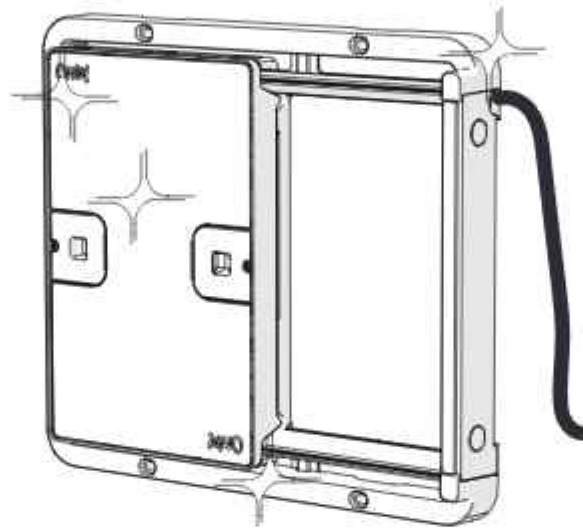

After rain in freezing temperatures, sleet or snow you may need to defrost your Autodoor to restore proper function to moving parts. To do this we recommend pouring warm (not boiling) water over any affected parts and then drying them. 

- **DE** Nach Regen bei frostigen Temperaturen, Schneeregen oder Schnee müssen Sie Ihre Autodoor eventuell enteisen, um die Funktion der beweglichen Teile wiederherzustellen. Dazu empfehlen wir, die betroffenen Teile mit warmem (nicht kochendem) Wasser zu übergießen und anschließend zu trocknen.
- **FR** Après une pluie par temps de gel, ou lorsqu'il y a de la neige fondue ou de la neige, il peut être nécessaire de dégivrer votre Porte Automatique afin de rétablir le bon fonctionnement des pièces mobiles. Dans cette situation, nous vous recommandons de verser de l'eau chaude (non bouillante) sur toutes les pièces concernées, puis de les sécher.
- **NL** Na regen bij vriestemperaturen, ijzel of sneeuw kan het nodig zijn om uw Autodoor te ontdooien. Dit om een goede werking van bewegende delen te garanderen. We raden aan dit te doen door warm (niet kokend) water over de betreffende delen te gieten en deze daarna af te drogen.
- **IT** Dopo la pioggia se le temperature ghiacciano, grandine e neve potrebbero portarvi a sghiacciare la vostra Autodoor per ripristinare le corrette funzioni delle parti mobili. Per farlo, raccomandiamo di versare dell'acqua calda (non a ebollizione) sulle parti interessate e poi asciugarle.
- **SE** Efter att det snöat eller regnat vid minusgrader kan du behöva frosta av din dörr för att se till att alla rörliga delar fungerar som de ska. Vi rekommenderar att hålla varmt (inte kokande) vatten över de delar som påverkats och sedan torka dem.
- **DK** Efter regn i temperaturer under frysepunktet, slud eller sne kan du være nødsaget til at afrime din automatiske dør til hønsehuset for at genoprette korrekt funktion for de bevægelige dele. For at gøre dette anbefaler vi, at du hælder varmt (ikke kogende) vand henover berørte dele og derefter tørrer dem af.

DE Anleitung zur Tiefenreinigung · FR Guide de nettoyage en profondeur · NL Gids voor diepe reiniging
 IT La guida ad una pulizia profonda · SE Guide för djuprengöring · DK Vejledning til dyb rengøring

You will need...

DE Das werden Sie benötigen · FR Ce dont vous aurez besoin · NL Ook heeft u nodig... · IT Avete anche bisogno di...
 SE Du behöver också... · DK Du skal også bruge...



Pet Safe Disinfectant



- DE Desinfektionsmittel für Haustiere
- FR Désinfectant pour animaux de compagnie
- NL Huisdierveilig desinfectiemiddel
- IT Disinfettante sicuro per animali domestici
- SE Desinfektionsmedel för husdjur
- DK Kæledyr desinfektionsmiddel

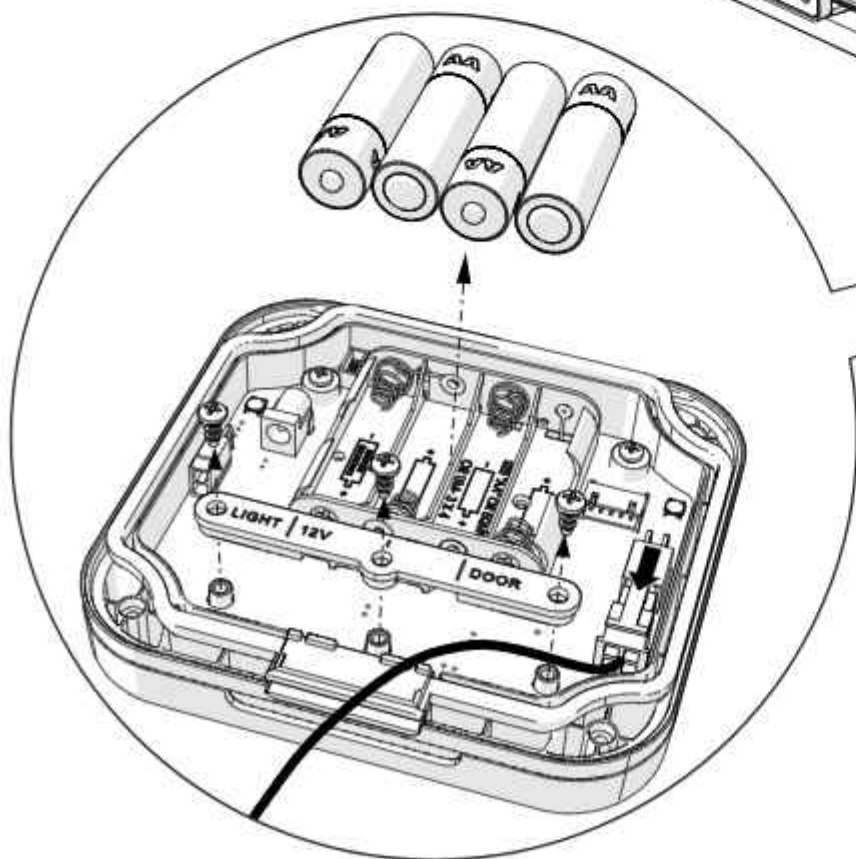
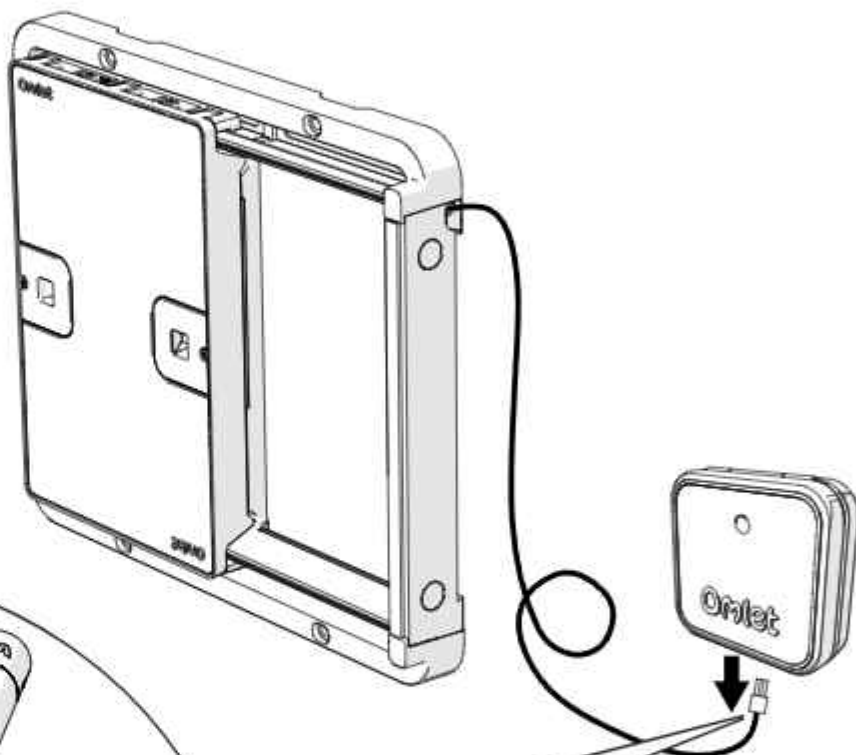

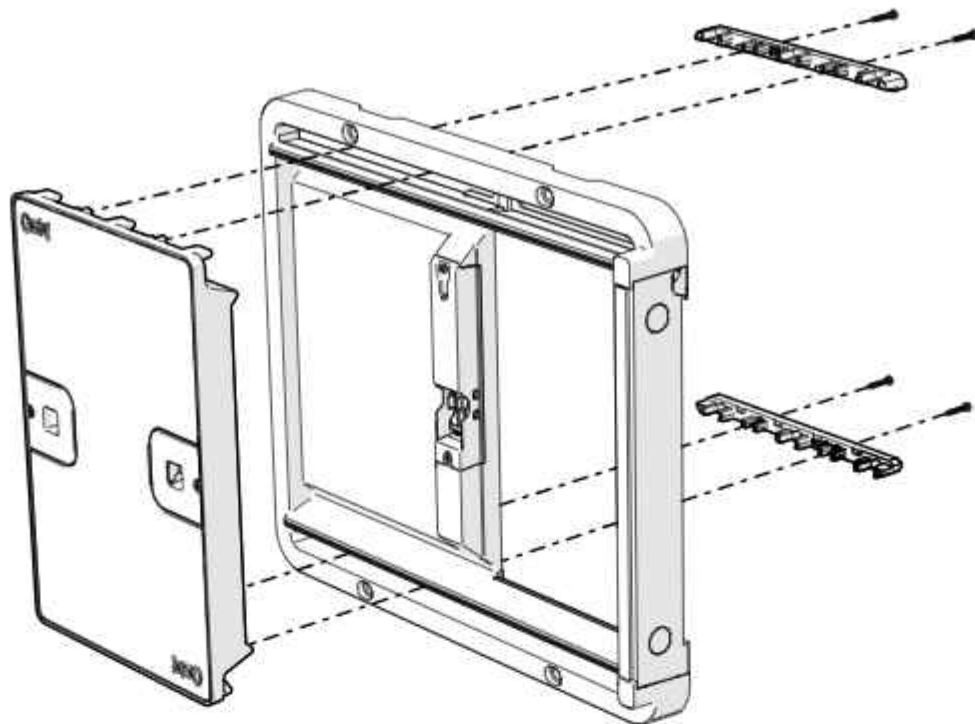
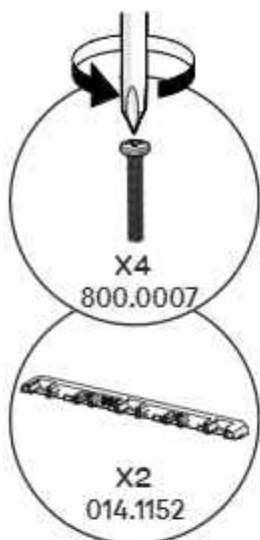
75

Keep the Parts safe until Step 94



- DE Legen Sie die Teile bis Schritt 94 beiseite
- FR Mettez ces pièce de côté pour l'étape 94
- NL Leg de onderdelen opzij tot stap 94
- IT Mettere da parte fino al Punto 94
- SE Lägg undan delarna till Steg 94
- DK Læg delene til side indtil trin 94

76

Door

DE Tür · FR Porte · NL Deur · IT Porta · SE Dörr · DK Dør

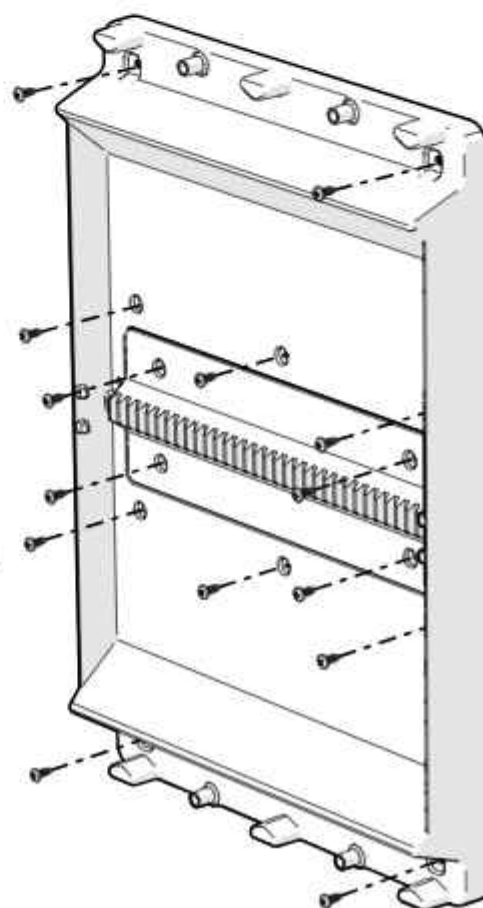

Keep the Parts safe until Step 82



- DE Legen Sie die Teile bis Schritt 82 beiseite
- FR Mettez ces pièce de côté pour l'étape 82
- NL Leg de onderdelen opzij tot stap 82
- IT Mettere da parte fino al Punto 82
- SE Lägg undan delarna till Steg 82
- DK Læg delene til side indtil trin 82

77

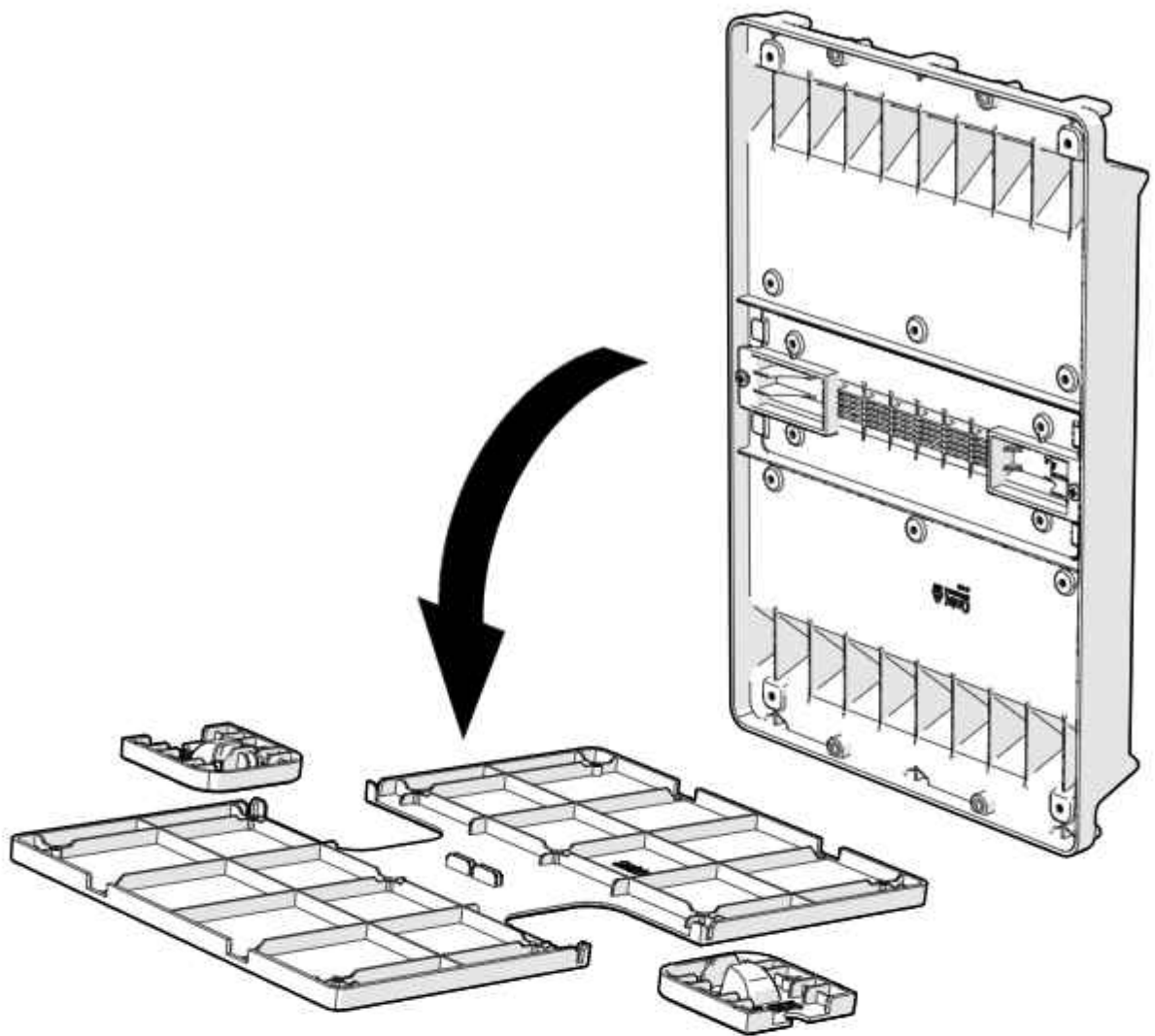

78

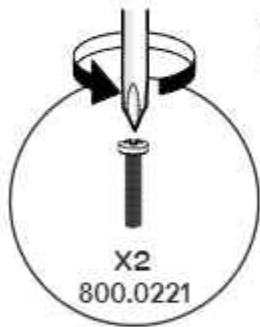

Keep the Parts safe until Step 80



- DE Legen Sie die Teile bis Schritt 80 beiseite
- FR Mettez ces pièces de côté pour l'étape 80
- NL Leg de onderdelen opzij tot stap 80
- IT Mettere da parte fino al Punto 80
- SE Lågg undan delarna till Steg 80
- DK Læg delene til side indtil trin 80

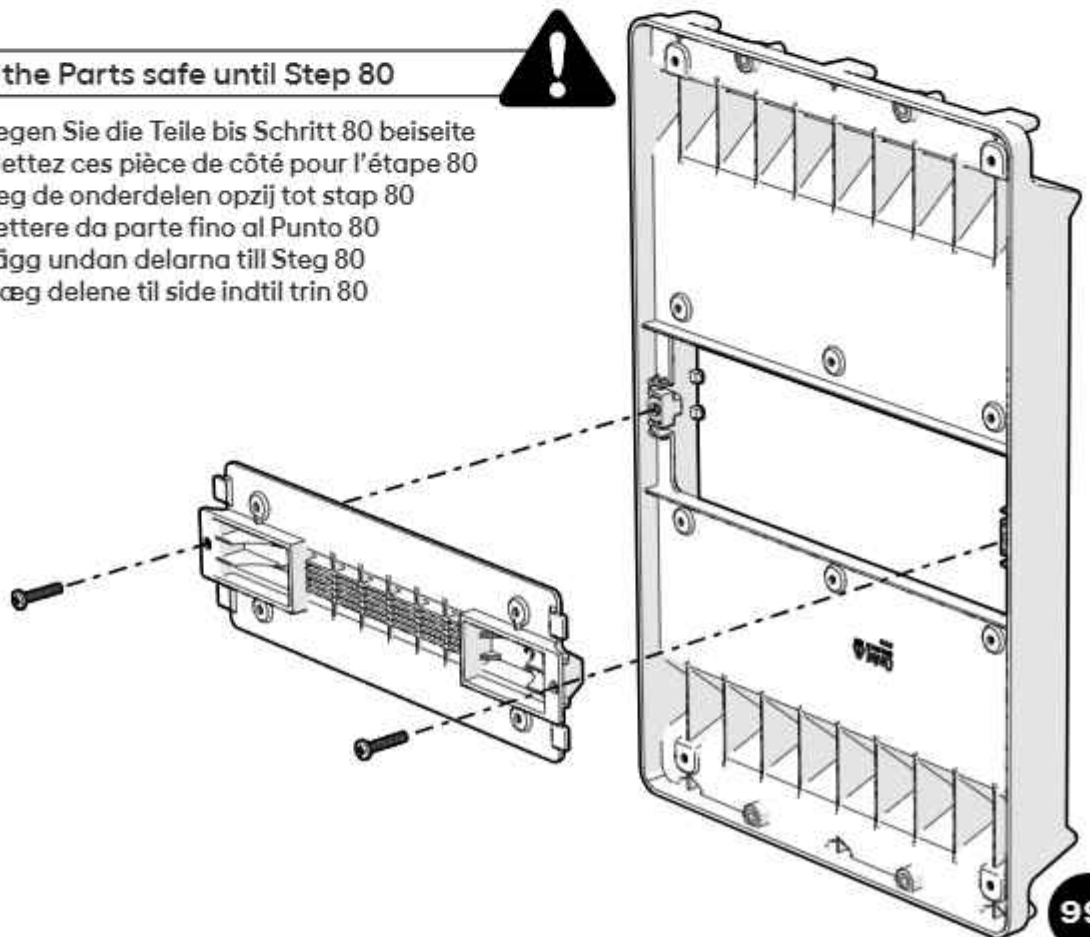

79

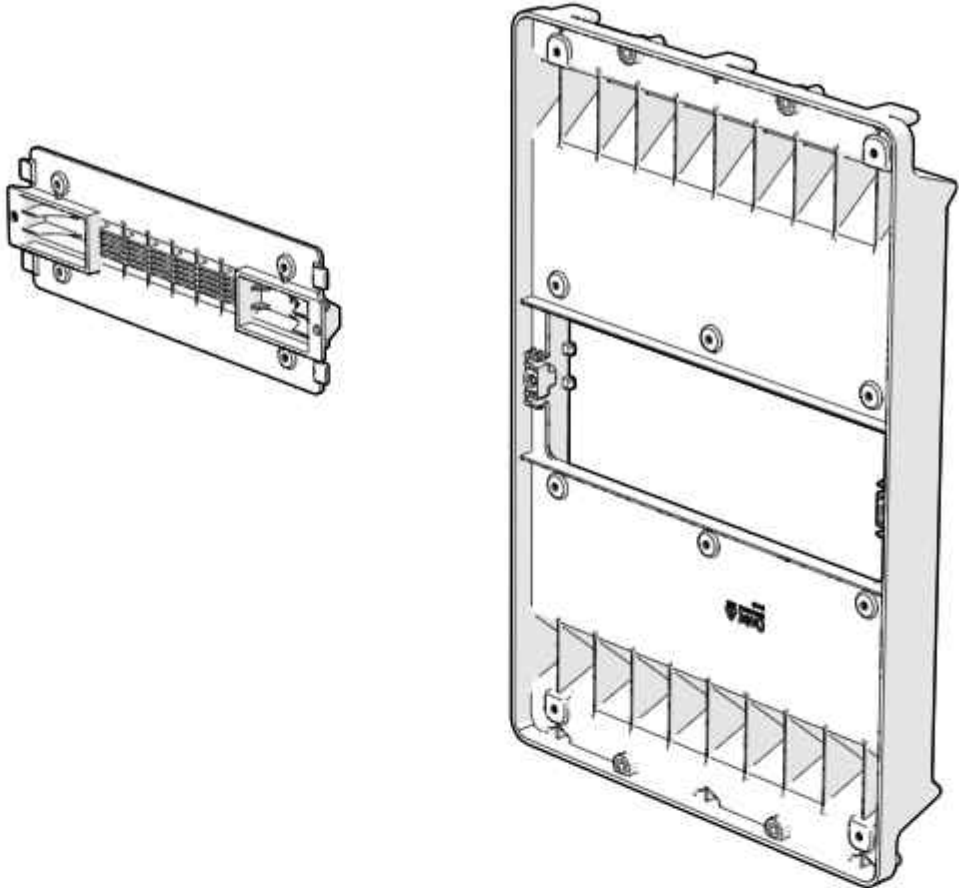

80

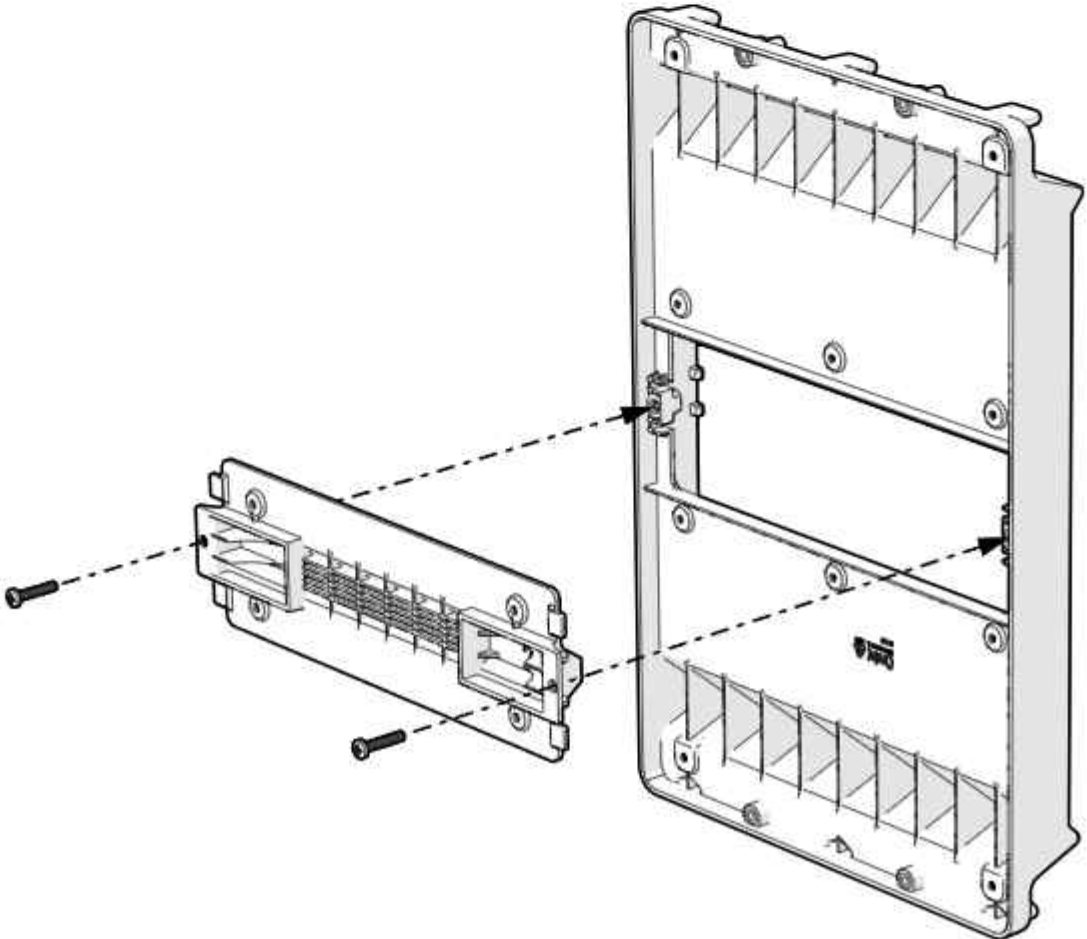

81

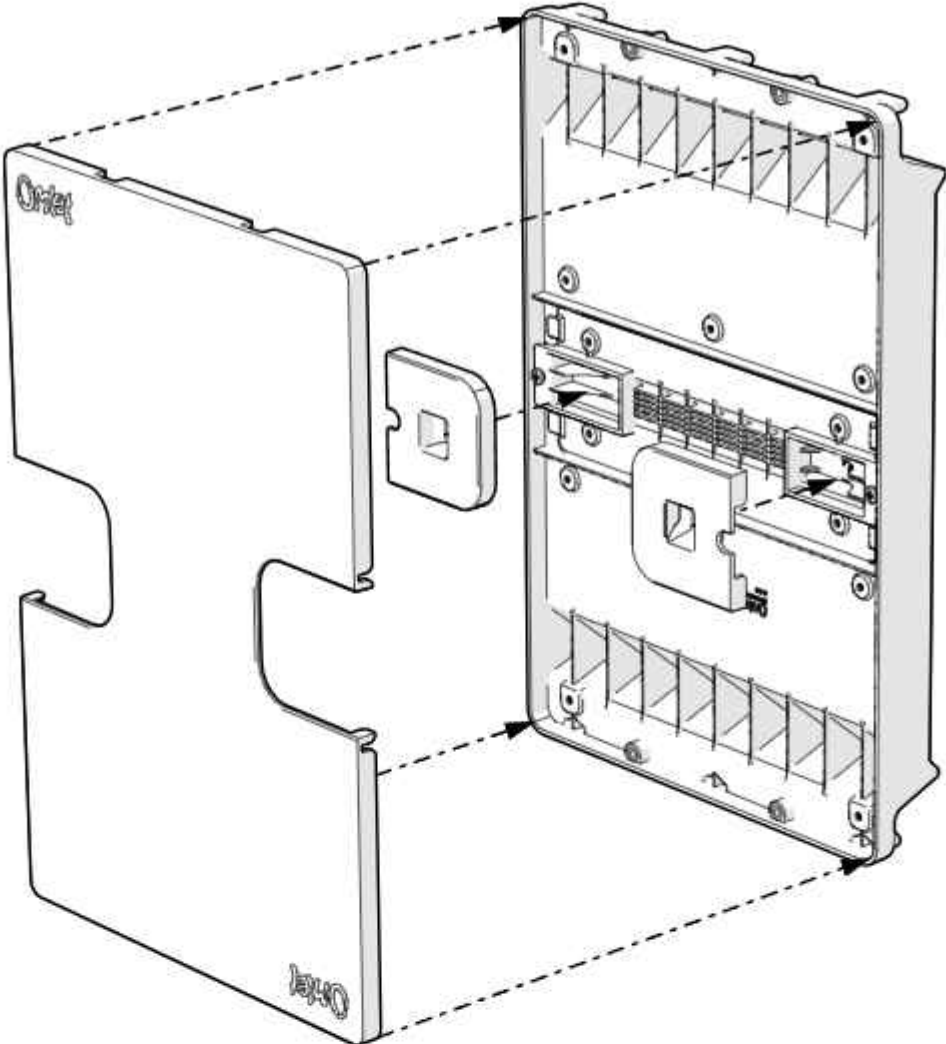

82

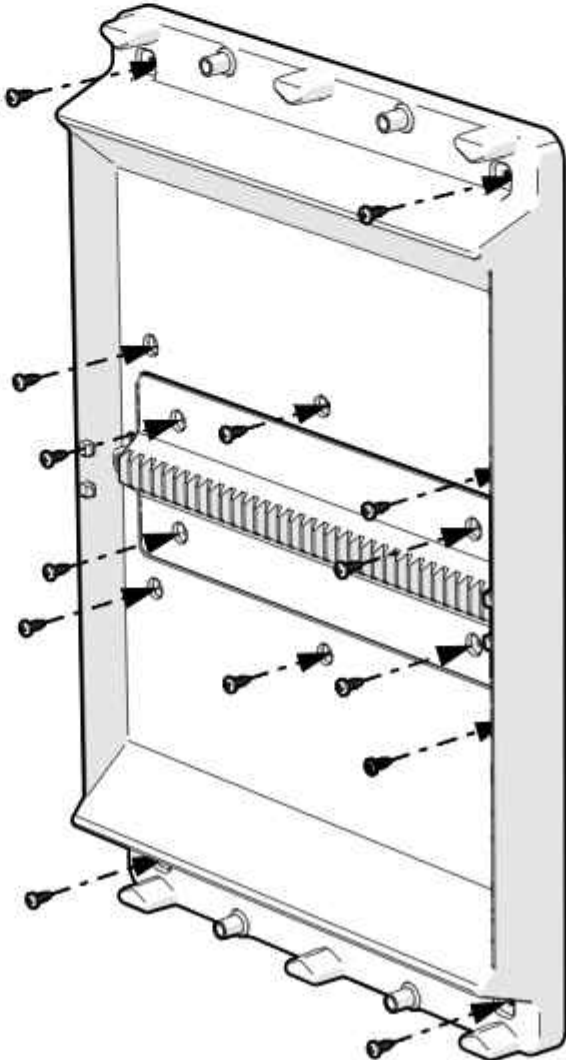

83**Frame**

DE Rahmen · FR Cadre · NL Frame · IT Cornice · SE Ram · DK Ramme

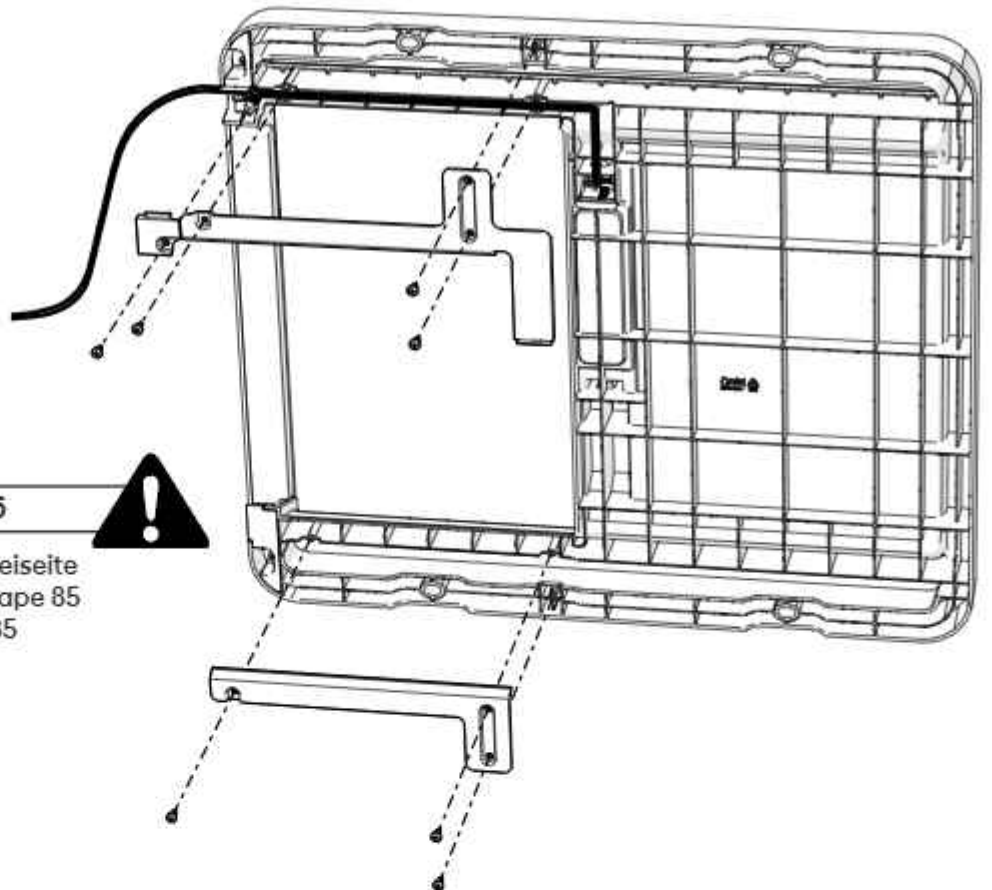
**Keep the Parts safe until Step 85**

- DE Legen Sie die Teile bis Schritt 85 beiseite
- FR Mettez ces pièces de côté pour l'étape 85
- NL Leg de onderdelen opzij tot stap 85
- IT Mettere da parte fino al Punto 85
- SE Lågg undan delarna till Steg 85
- DK Læg delene til side indtil trin 85

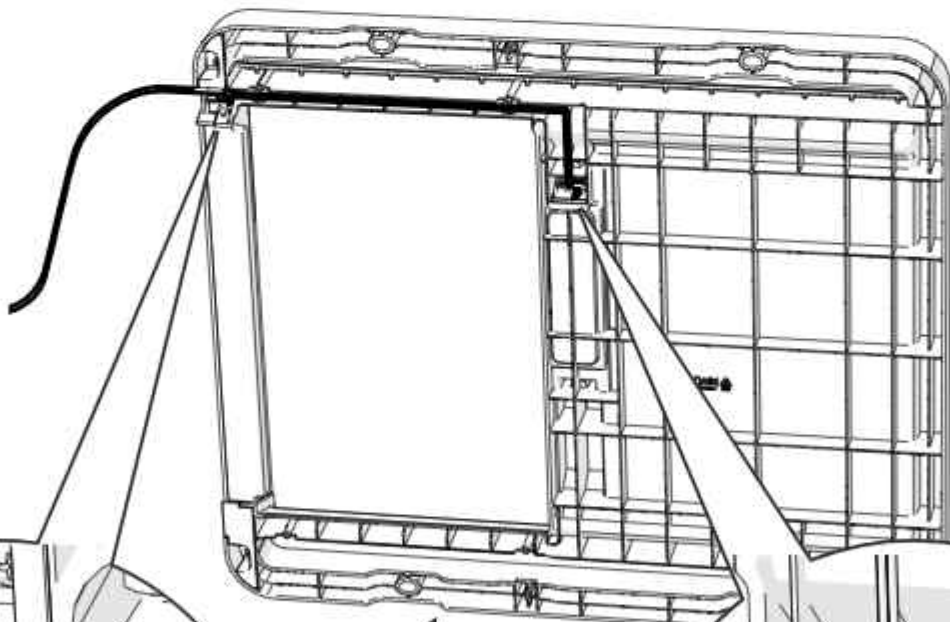
84**Keep Dry!**

- DE Trocken halten!
- FR Garder au sec!
- NL Droog houden!
- IT Tenere all'asciutto!
- SE Håll torr!
- DK Hold tør!

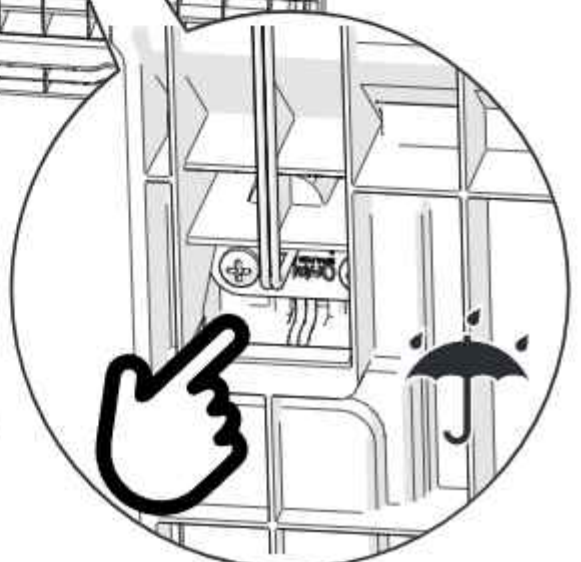
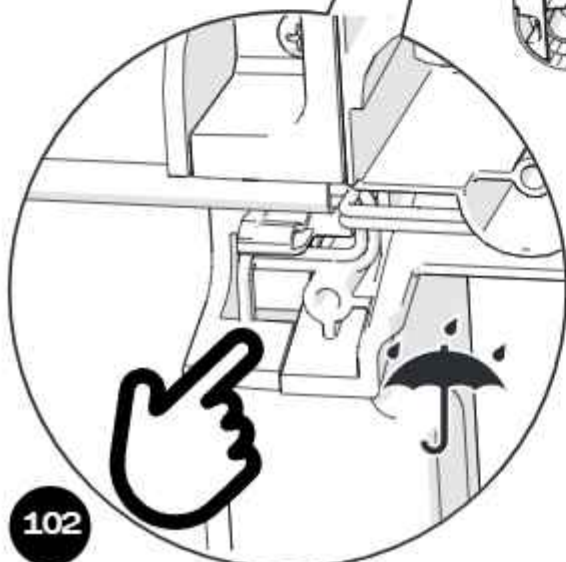

85

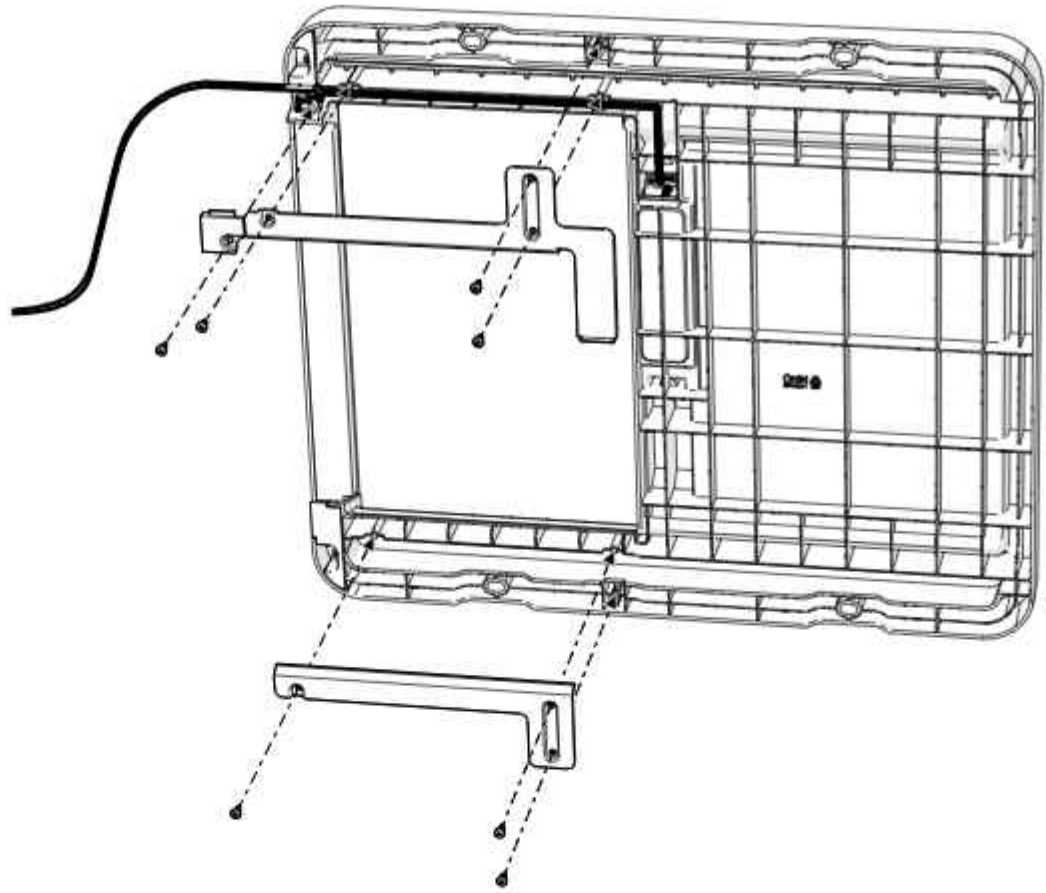

86

Safety Sensor

DE Sicherheitssensor · FR Détecteur d'obstacle · NL Veiligheidssensor · IT Sensore di Sicurezza
SE Säkerhetssensor · DK Sikkerhedssensor

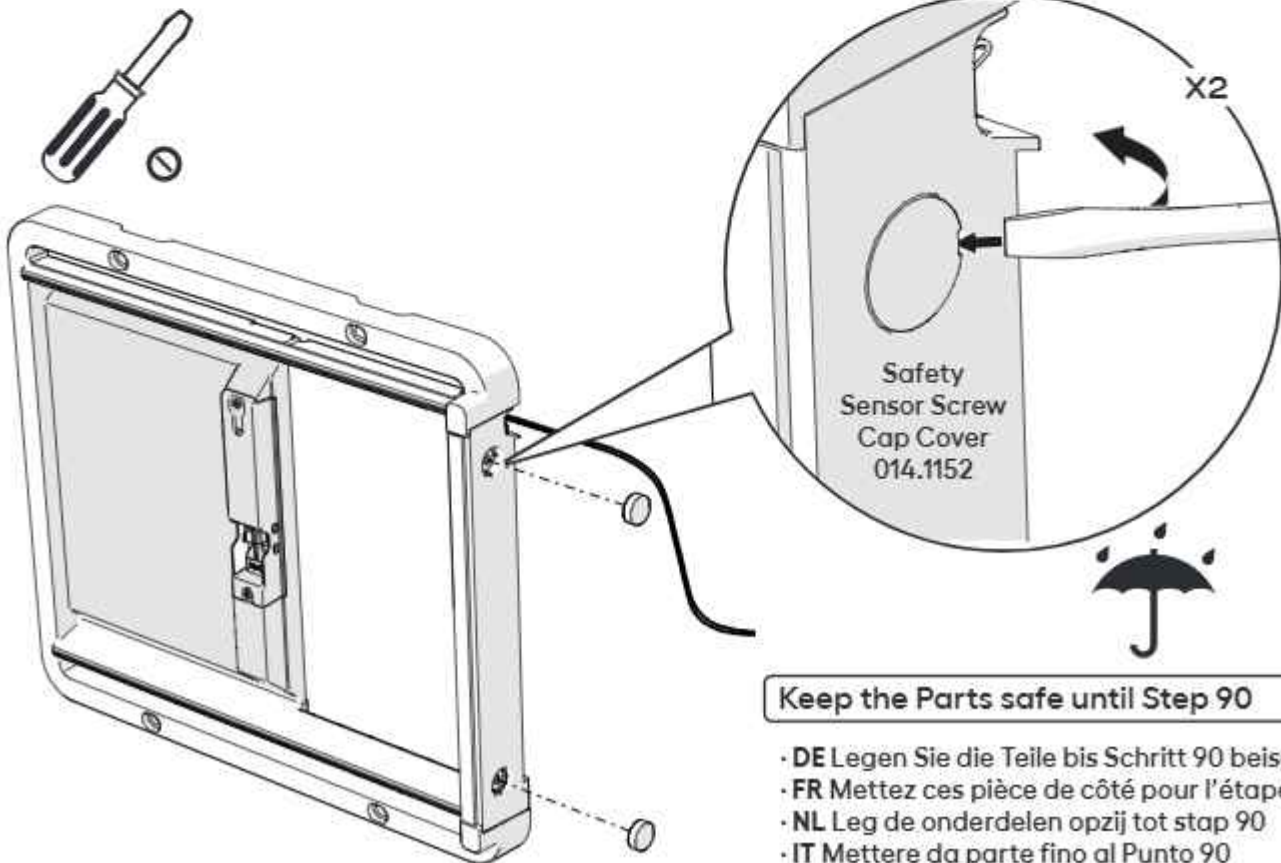

Keep the Parts safe until Step 90

- DE Legen Sie die Teile bis Schritt 90 beiseite
- FR Mettez ces pièce de côté pour l'étape 90
- NL Leg de onderdelen opzij tot stap 90
- IT Mettere da parte fino al Punto 90
- SE Lägg undan delarna till Steg 90
- DK Læg delene til side indtil trin 90

87

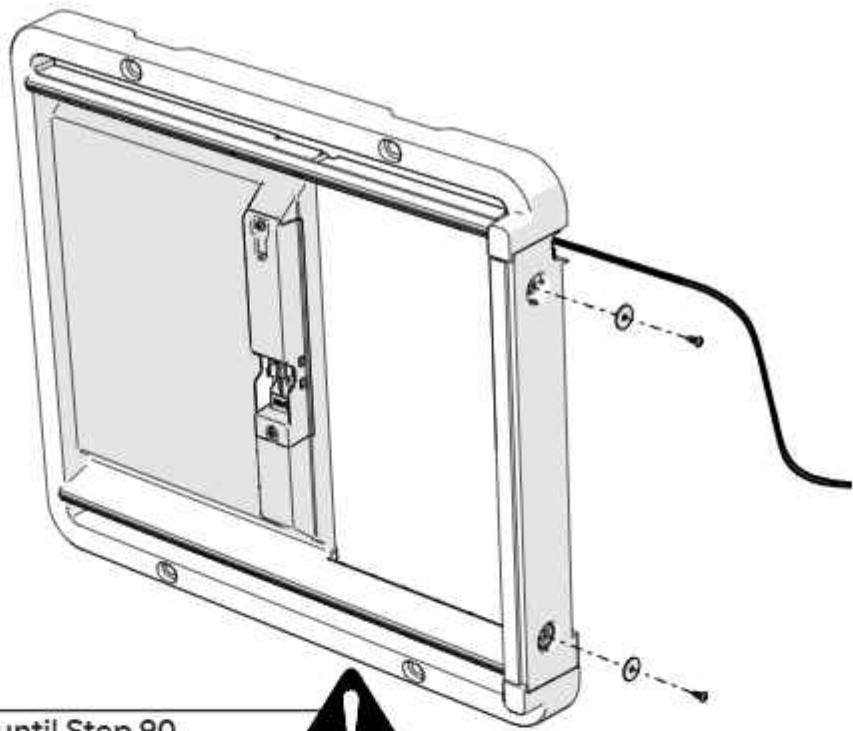
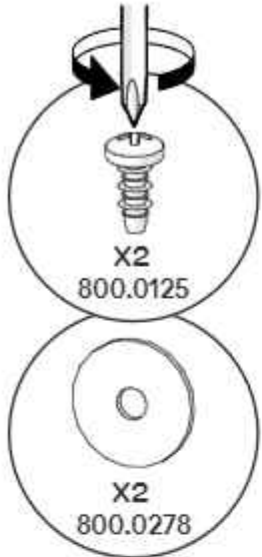

Keep the Parts safe until Step 90



- DE Legen Sie die Teile bis Schritt 90 beiseite
- FR Mettez ces pièces de côté pour l'étape 90
- NL Leg de onderdelen opzij tot stap 90
- IT Mettere da parte fino al Punto 90
- SE Lägg undan delarna till Steg 90
- DK Læg delene til side indtil trin 90

88

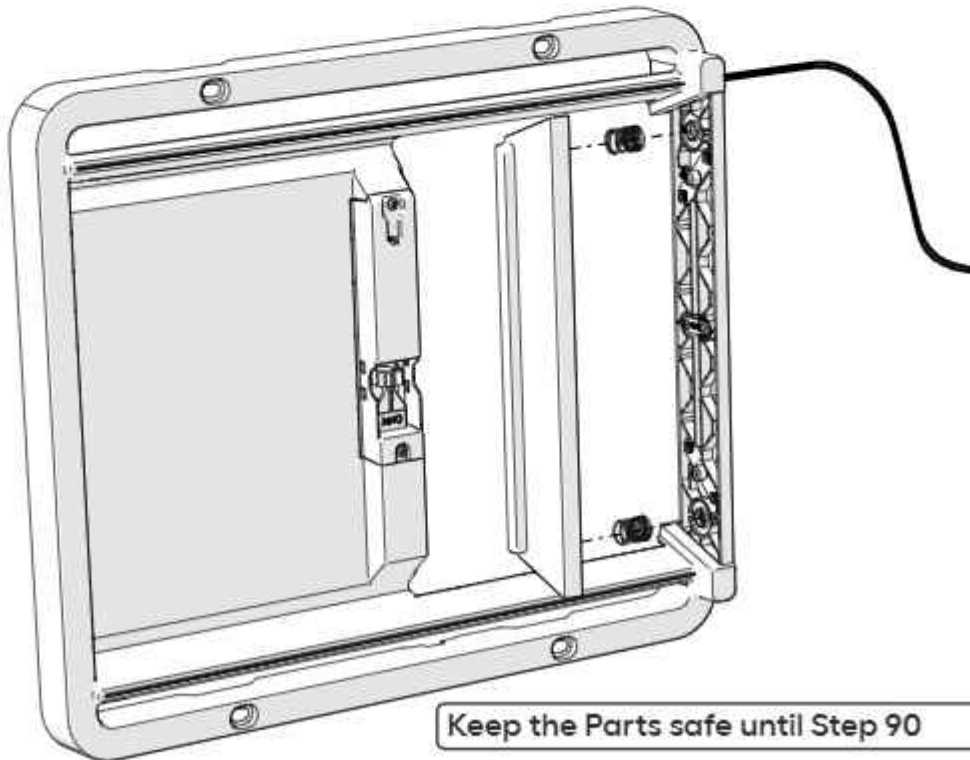
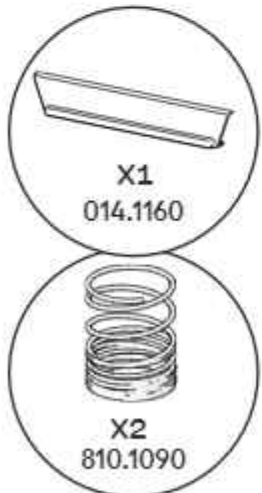

Keep the Parts safe until Step 90



- DE Legen Sie die Teile bis Schritt 90 beiseite
- FR Mettez ces pièces de côté pour l'étape 90
- NL Leg de onderdelen opzij tot stap 90
- IT Mettere da parte fino al Punto 90
- SE Lägg undan delarna till Steg 90
- DK Læg delene til side indtil trin 90

89

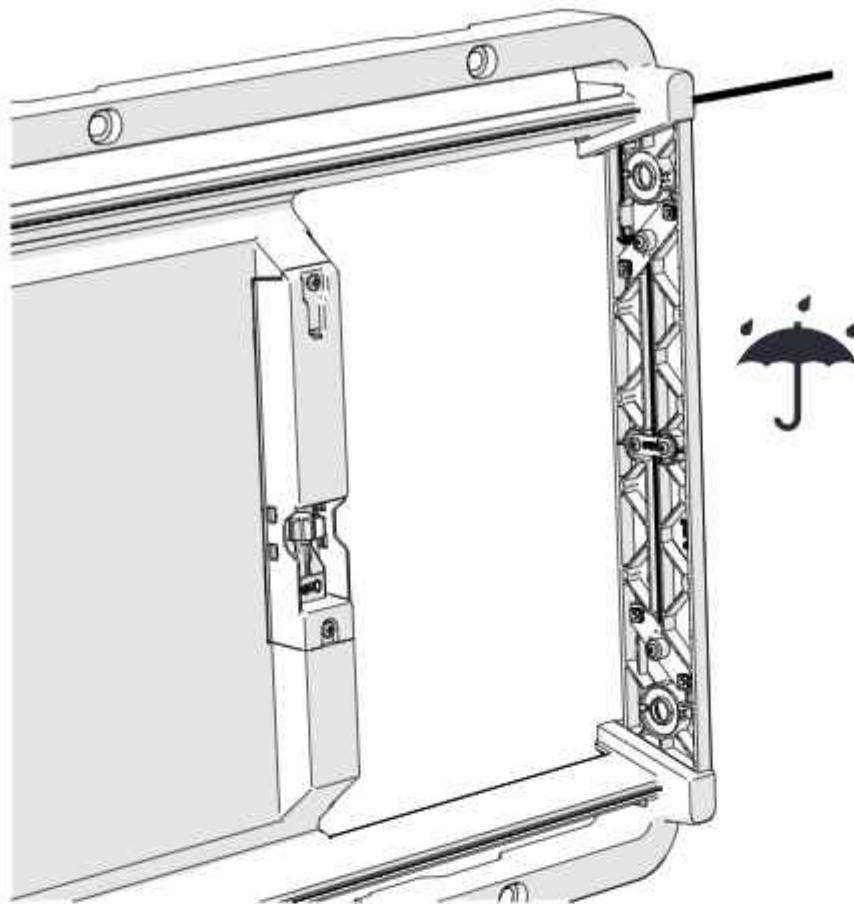

90

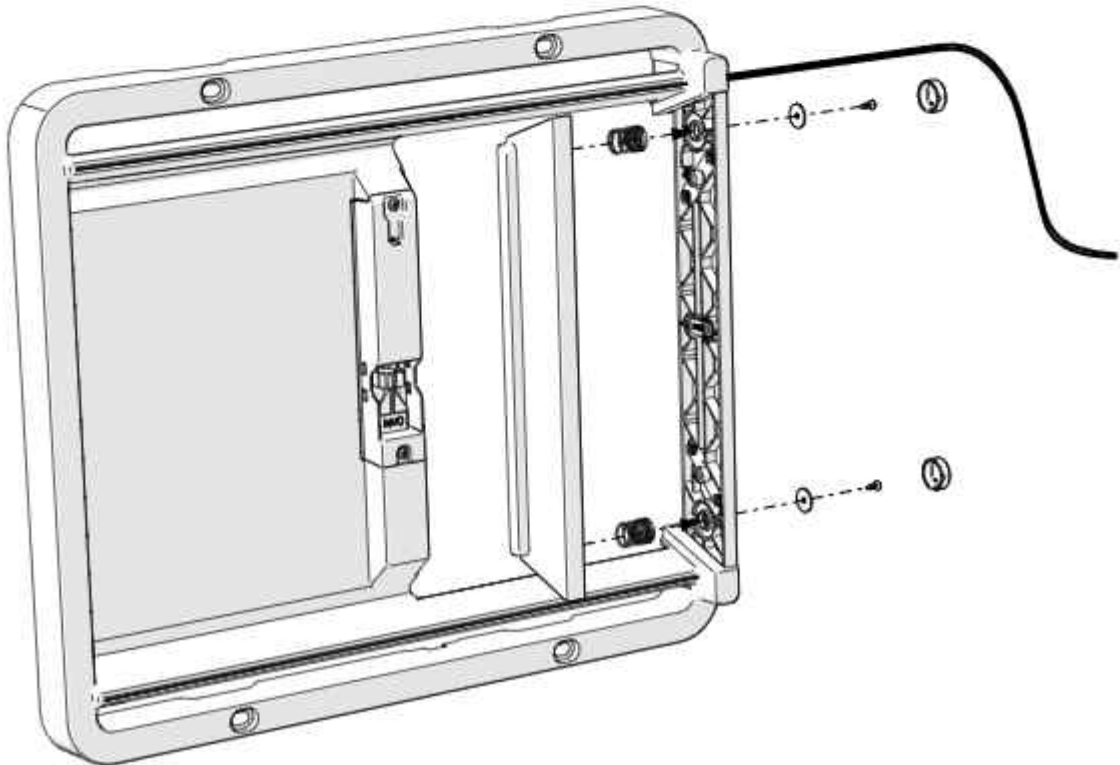
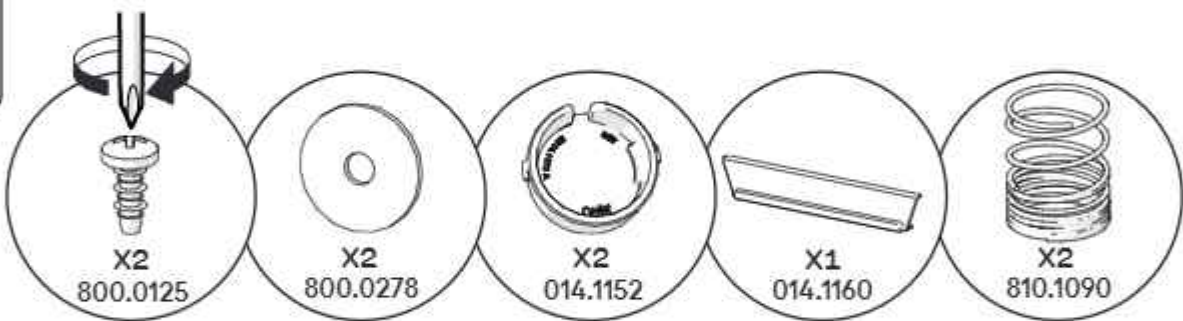

91**Motor Case**

DE Motorgehäuse · FR Carter moteur · NL Motorbehuizing · IT Cassa del Motore · SE Motorväska
 DK Motorhuset

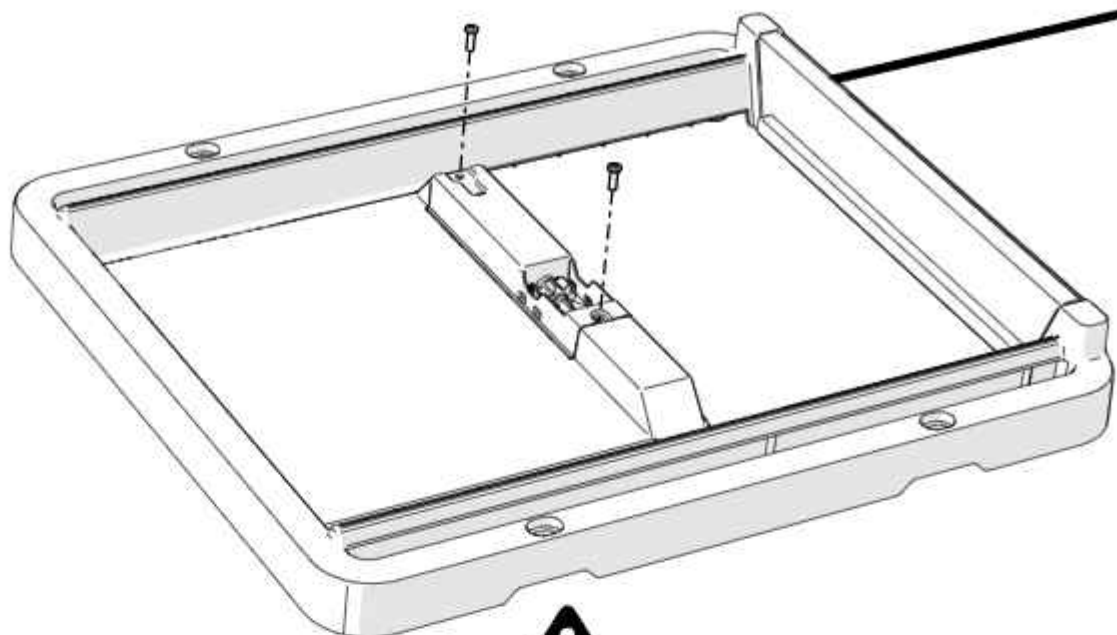

Keep the Parts safe until Step 93

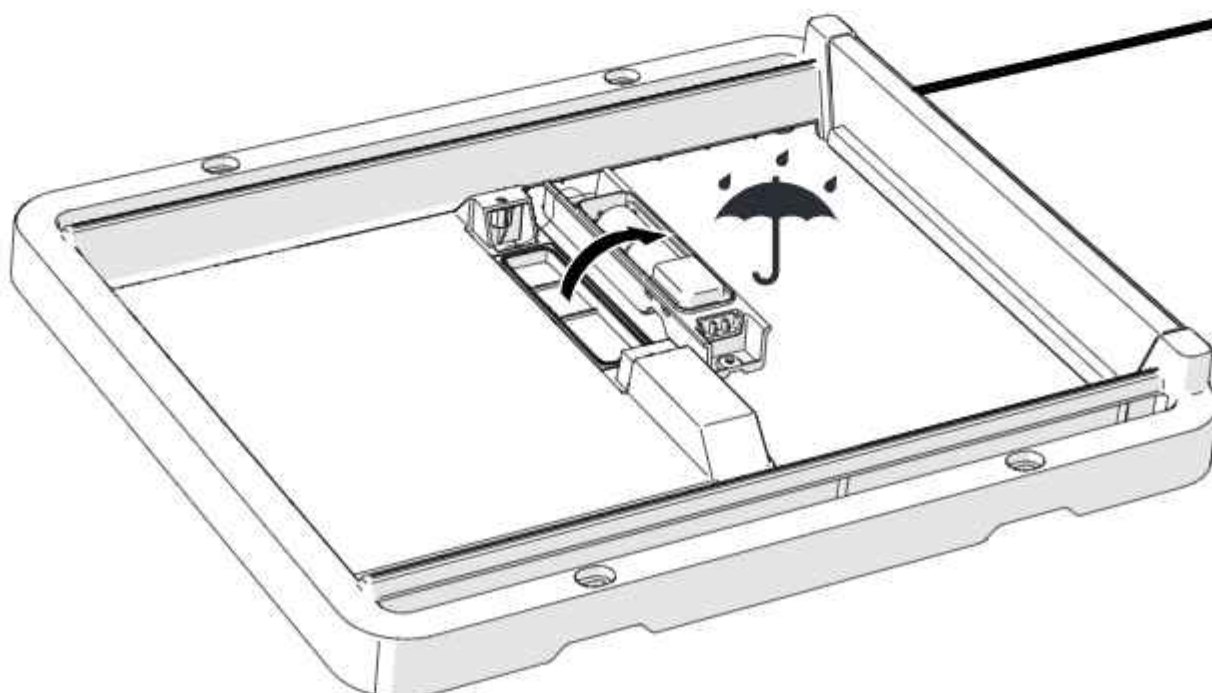

- DE Legen Sie die Teile bis Schritt 93 beiseite
- FR Mettez ces pièce de côté pour l'étape 93
- NL Leg de onderdelen opzij tot stap 93
- IT Mettere da parte fino al Punto 93
- SE Lägg undan delarna till Steg 93
- DK Læg delene til side indtil trin 93

92

93

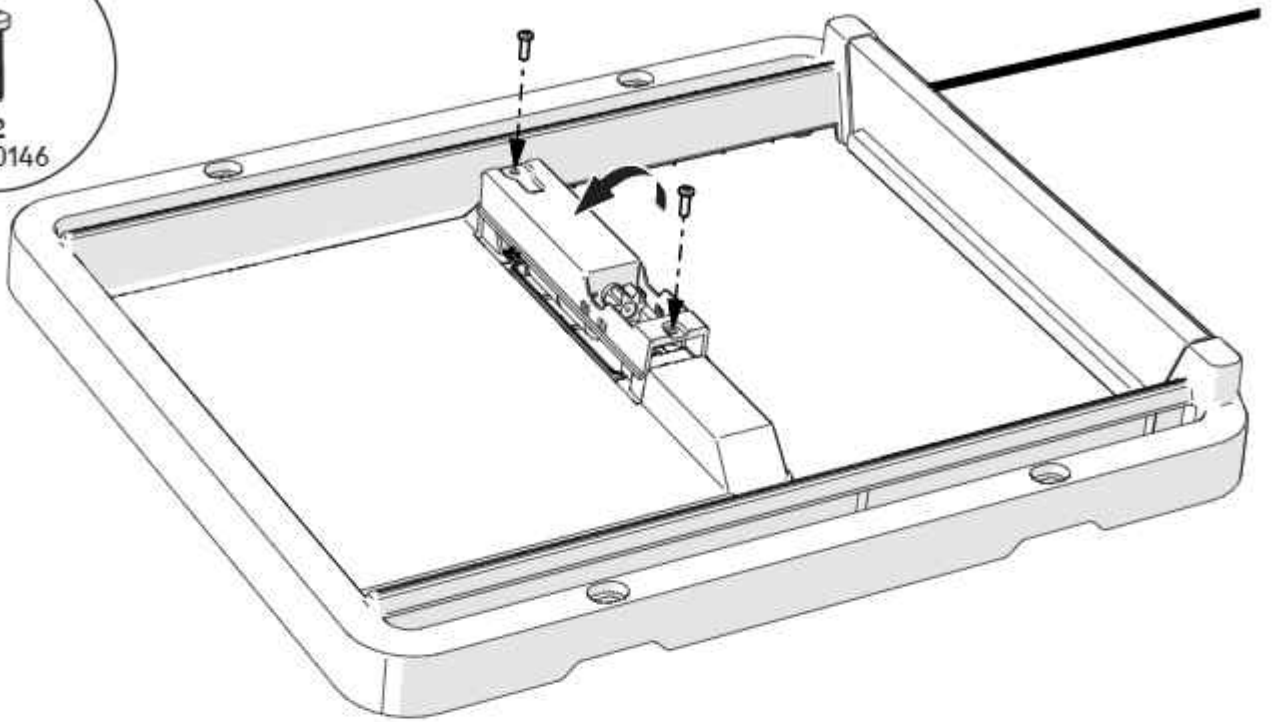

94

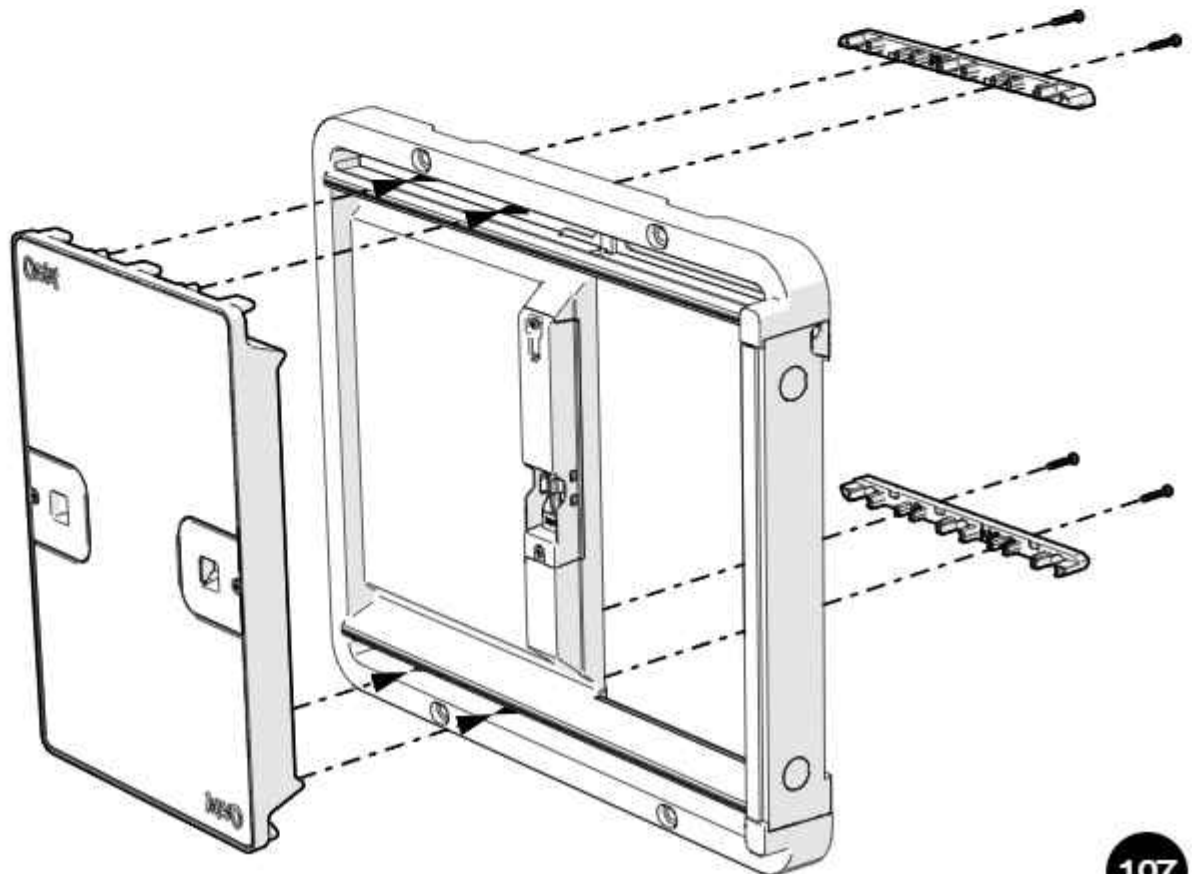

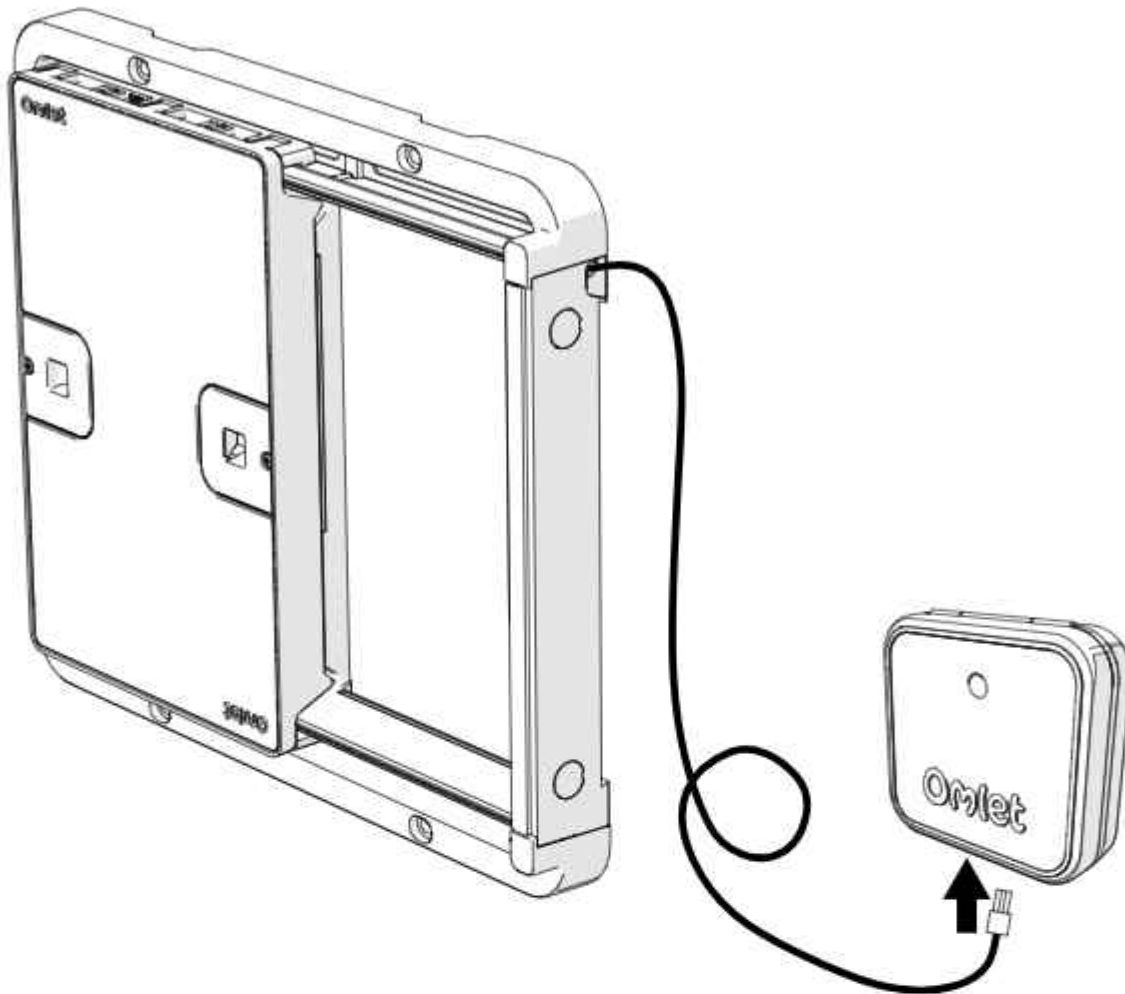

Plug the Door back in again. It will recalibrate

- DE Schliessen Sie die Tür wieder an. Sie wird sich automatisch kalibrieren
- FR Reconnectez la Porte Automatique à son boîtier. Elle se recalibrera d'elle-même
- NL Sluit de Autodoor weer aan. Deze zal herkalibreren
- IT Ricollegate nuovamente la porta. Si ricalibrerà da sola
- SE Koppla in dörren igen. Den kommer kalibrera
- DK Tilslut døren igen. Det bliver recalibreret

DE Den Sicherheitssensor testen · FR Test du détecteur d'obstacles · NL Het testen van de knel-detector
 IT Testare il sistema a fotocellula · SE Testa krossdetektorn · DK Afprøvning af sikkerhedssensoren

Wait for the door to close automatically or close it by Pressing & Holding **OK** button.

- DE Der Test wird durchgeführt wenn die Tür dabei ist sich zu schließen. Sie können warten, bis sie sich automatisch schließt, oder sie können die OK Taste drücken und halten, um die Tür zu schließen
- FR Attendez que la porte se ferme d'elle-même, ou appuyez longuement sur OK pour activer sa fermeture.
- NL Wacht totdat de deur automatisch sluit of sluit de deur door OK ingedrukt te houden.
- IT Attendere che la porta si chiuda automaticamente. In alternativa, chiudete la porta tenendo premuto il pulsante OK.
- SE Vänta på att dörren stängs automatiskt eller stäng den genom att hålla ner OK-knappen.
- DK Vent til døren lukker automatisk eller luk døren ved at trykke OK og holde knappen inde.

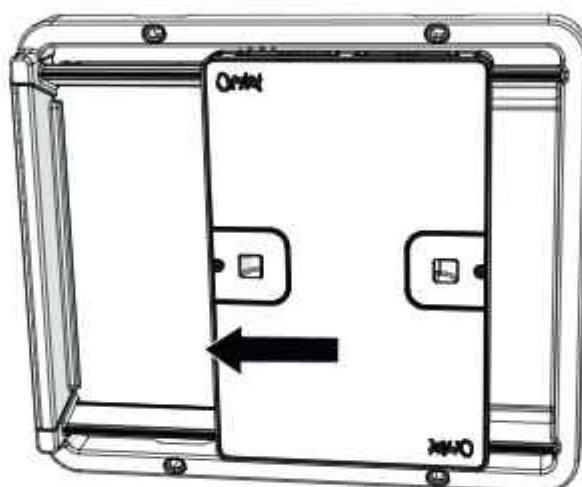

Put an object in the door. The object exerts pressure on the Crush Detector.

- DE Legen Sie einen Gegenstand in die Türöffnung. Sobald die Tür Druck auf das Objekt ausübt, wird dieses an die Sicherheitssensor-Leiste geschoben
- FR Placez un objet dans le passage de la porte. Celui-ci exerce une pression sur le détecteur d'obstacles.
- NL Zet een object in de deuropening. Wanneer de deur tegen het object duwt wordt druk uitgeoefend op de knel-detector.
- IT Posizionate un qualsiasi oggetto all'ingresso.
- SE Sätt någonting i vägen för dörren. Objektet som puttas av dörren sätter press på krossdetektorn.
- DK Sæt et objekt i døråbningen. Objektet skubbes af døren, når denne lukker, og trykker dermed på sikkerhedssensoren.

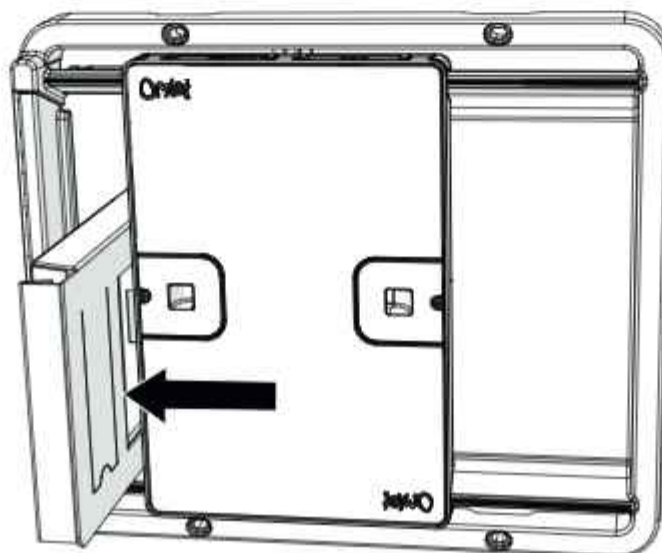

The Crush Detector will stop the door and make it open. The door will automatically try to close **4 more times**. If it is still blocked, it will eventually stop in the fully open position.

- **DE** Der Druck auf die Sicherheitssensor-Leiste sorgt dafür, dass die Tür sich sofort wieder öffnet. Die Tür wird nach viermal versuchen, sich zu schließen. Wenn Sie dann noch immer blockiert ist, wird sie offen bleiben.
- **FR** Le détecteur d'obstacles va arrêter la porte et la fera s'ouvrir à nouveau. Ensuite, la porte va essayer de se fermer à 4 reprises. Si elle se bloque à nouveau, elle se rouvrira.
- **NL** De knel-detector stopt de deur en opent deze. De deur zal automatisch nog 4 pogingen doen om te sluiten. Indien de deur nog steeds wordt geblokkeerd zal deze in de volledig geopende positie eindigen.
- **IT** Il sensore bloccherà e aprirà nuovamente la porta. La porta cercherà di chiudersi automaticamente per altre 4 volte. Se l'ingresso è ancora ostruito, il sistema bloccherà permanentemente la porta in posizione aperta.
- **SE** Krossdetektorn hindrar dörren och gör att den öppnas. Dörren kommer försöka stängas automatiskt 4 gånger till. Om den efter det fortfarande är blockerad kommer den återgå till öppet läge.
- **DK** Sikkerhedssensoren stopper døren og får den til at åbne igen. Døren vil automatisk forsøge at lukke 4 gange mere. Hvis der fortsat er noget, der blokerer døren, vil den til sidst stoppe i helt åben tilstand.

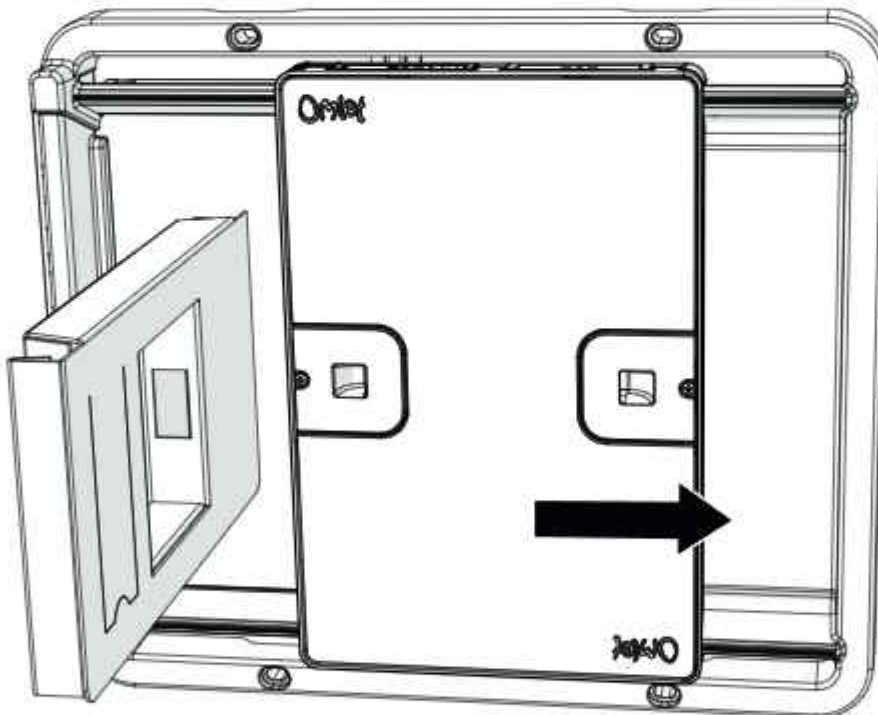

For the Troubleshooting guide you can scan the code or visit: www.omlet.co.uk/instructions



- **DE** Für die Anleitung zur Fehlerbehebung können Sie den Code scannen oder diese Seite besuchen: www.omlet.de/anleitungen

- **FR** Pour le guide de dépannage, scannez le code ou consultez le site : www.omlet.fr/instructions

- **NL** Scan de code voor de gids 'Problemen oplossen' of ga naar: www.omlet.nl/gebruiksaanwijzing

- **IT** Per la guida alla soluzione dei problemi potete scansionare il codice o visitare: www.omlet.it/istruzioni

- **SE** För hjälp med felsökning kan du skanna koden eller besöka: www.omlet.se/bruksanvisning

- **DK** Fejlfindingsmanualen kan findes ved at scanne koden eller besøge: www.omlet.dk/brugsanvisning



CONNECT, WHEREVER YOU ARE



Omlet

© Copyright Omlet Ltd. 2025

Design registered, patent pending

Omlet and Autodoor are registered trademarks of Hebe Studios Ltd.

820.2298 Instruction Manual Smart AutoDoor_ 31/03/2025



FR

Cet appareil,
ses accessoires
et cordons
se recyclent



À DÉPOSER
EN MAGASIN



À DÉPOSER
EN DÉCHÈTÈRIE



Please
reuse &
recycle.

Points de collecte sur www.quefais-je.com/recycle
Pratiquer la réparation ou le don de votre appareil !

